

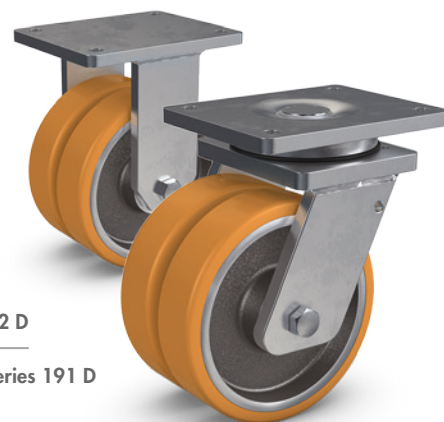









PE·VO·PUR® heavy-duty castors



Series 192 D

Series 191 D

								
Article code	mm	mm	mm	mm	mm	mm	mm	kg
191 D/125/50/5	125	2 x 50	180	175 x 140	140 x 105	15	49	1.100
191 D/150/50/5	150	2 x 50	210	200 x 160	160 x 120	15	50	1.350
191 D/200/50/5	200	2 x 50	260	200 x 160	160 x 120	15	60	2.000
191 D/250/60/5	250	2 x 60	320	250 x 200	210 x 160	19	70	2.700
191 D/250/80/5	250	2 x 80	320	250 x 200	210 x 160	19	70	3.600
191 D/300/80/5	300	2 x 80	380	250 x 200	210 x 160	19	80	4.300

Heavy-duty twin wheel swivel castors with PEVOPUR® wheels

Wheels series 178 PUR with ball bearings (/5), see page 93.

							
Article code	mm	mm	mm	mm	mm	mm	kg
192 D/125/50/5*	125	2 x 50	180	175 x 140	140 x 105	15	1.100
192 D/150/50/5	150	2 x 50	210	200 x 160	160 x 120	15	1.350
192 D/200/50/5	200	2 x 50	260	200 x 160	160 x 120	15	2.000
192 D/250/60/5	250	2 x 60	320	250 x 200	210 x 160	19	2.700
192 D/250/80/5*	250	2 x 80	320	250 x 200	210 x 160	19	3.600
192 D/300/80/5*	300	2 x 80	380	250 x 200	210 x 160	19	4.300

Heavy-duty twin wheel fixed castors

* Plate alignment: Long side is parallel with wheel axle.

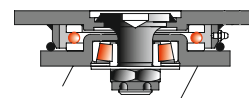

Precision heavy-duty swivel castor brackets with a load capacity of up to 4,300 kg

Housings in precise highly stable welded steel construction. Swivel head with a high quality thrust ball bearing and a tapered roller bearing for the guidance of the kingpin. All bearing parts dust and splash proof. Wheel locking on the non-trailing side of the housing.

ALLSTOP total locking device
Code: 191 D RF/...



4-way directional lock
Code: 191 D/...4RIF

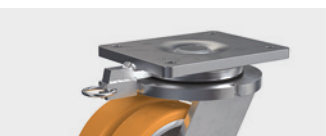

wheel and directional lock
Code: 191 D RF/...4RIF



foot protection
Code: ...PRO



PEVOPUR® - PEVOPLASTIC®
PEVOHAN®

Solid rubber wheels and castors

Electrically conductive wheels and castors

VULKOLAN® - PEVOPUR®
PEVOVYN® - Soft

Stainless steel castors

Institutional wheels and castors

Conveyor/guiding rollers and ball units

Profile rollers

Pallet rollers

Press-on tyres