



## **Our Warranty, Your Satisfaction.**

Since 2001, GRB Bearings, a 100% Canadian family owned company, has been a successful bearing supplier to distributors and OEMs across Canada. Our bearings are mainly imported from carefully selected manufacturers in China, and are made according to the international "ISO" quality control system, and under the minimum "ABEC 1" precision standard. Our confidence in our product is such, that we offer the best warranty in the industry.

If you are not totally satisfied with the quality of the bearings imported and manufactured under license for GRB, we will take them back (some conditions apply).

We are making it our duty to offer quality products to our customers; however, if an item happens to be defective, we will replace the product under the following conditions:

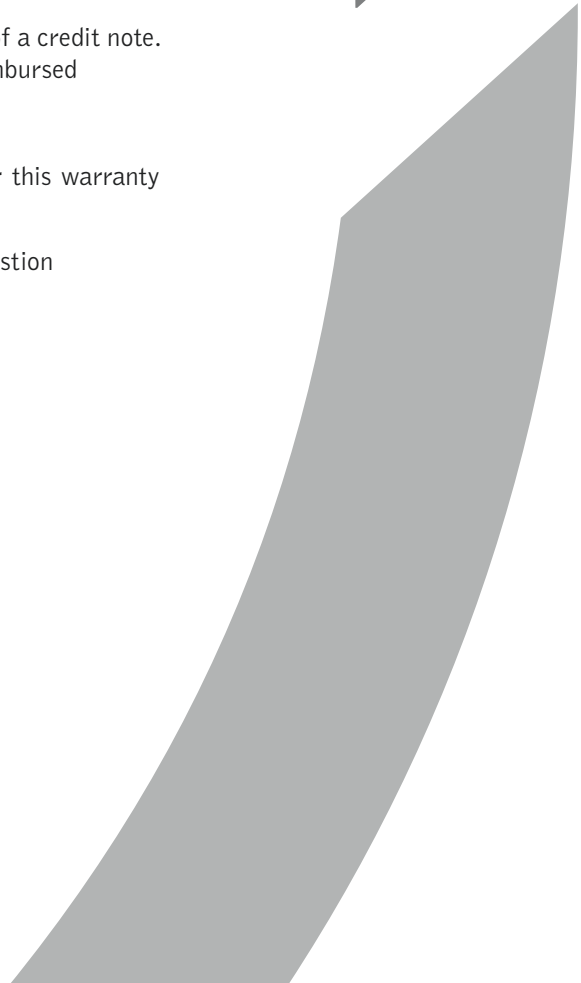
- The warranty is limited to the replacement or, at our discretion, the emission of a credit note. No other claims such as labour, loss or damage will be accepted and/or reimbursed
  - The warranty is limited to 90 days from date of invoice
  - Abusive usage, improper installation and/or inadequate maintenance render this warranty null and void
  - GRB reserves the right to verify the proper installation of the material in question
  - All parts must be returned prepaid to GRB
- 



# LEGAL NOTICE

## *Force Majeure*

GRB, our employees and/or agents take no responsibility for loss or damage occasioned by delay in delivery or inability to deliver, whether these events are caused by us, or arising from circumstances beyond our control such as acts of God, fire, accidents, strike, lockouts and/or any other similar causes.

## Disclaimer

We've taken the greatest care to insure the accuracy of the information contained in this catalog but GRB will not accept liability for any errors or omissions. Products presented in this catalog are not necessarily available from stock. Please contact GRB's sales representative for availability. The structure and technical data shown in this catalog are those being used at the time of publication and GRB reserves the right to make changes without notice. The information listed in this catalog is for reference only. Rest assured that any comment and suggestion will be considered with great care.

**Some sizes may not be available at the time of your order or might require a minimum quantity. Please check with your representative before making a definitive selection.**

## Other products available

- Ball Bearings, Metric & Inch Sizes
- Spherical Plain Bearings
- Rod Ends
- Needle Bearings
- Roller Bearings
- Cam Followers
- Tapered Roller Bearings
- Thrust Bearings
- Pillow Blocks & Inserts
- Conveyor Bearings

And more!

Visit our website at **[www.GRBBearings.com](http://www.GRBBearings.com)** for up to date information!

# TABLE OF CONTENTS



## Ball Bearings

Miniature & Instrument Ball Bearings Metric Series .....	4-6
Miniature & Instrument Ball Bearings Metric Flanged Series .....	7-8
Miniature & Instrument Ball Bearings Inch Series .....	9-10
Miniature & Instrument Ball Bearings Inch Series (1600) .....	11

## Single Row Radial Ball Bearings

Metric Series (16000 / 6700 / 6800 / 6900 / 6000) .....	12-14
(6200 / 6300 / 6400) .....	15-16
Maximum-Capacity Type-Series (BL200 - BL300) .....	17
Double Row Ball Bearings (5200 / 5300) .....	18
Angular Contact Ball Bearings (7200 / 7300) .....	19-20
Single Direction Thrust Ball Bearing (51100 / 51200 / 51300) .....	21
Radial Ball Bearings Inch Series (7500 DLG / 7600 DLG) .....	22
Tapered Roller Bearings Metric Series (30200 / 30300 / 31300 / 32000 / 32200 / 32300 / 33100) .....	23-27
Tapered Roller Bearings Inch Series (Cups & Cones) .....	28-33

## Needle Bearings

Cam Followers (CRSB DIM / CRSB Mounting) .....	34-35
Track Roller (YCRS DIM / YCRS Mounting) .....	36-37
Inner Race .....	38-41
HJ/IR .....	42-45 / 47
HJ-RS / HJ-2RS .....	46
Drawn Cup Clutch Bearings RC & RCB .....	48
Thrust Needle Bearing (NTA / Thrust Washers) .....	49-51

## Spherical Plain

(GE ES/2RS / GEG ES/2RS / GEEW ES / GEEM ES/2RS / GEZ ES/2RS / GEWZ ES/2RS / GEGZ ES/2RS / GE & GEG..C / GE ET/2RS - GE XT/2RS / GEZ ET-2RS / GACZ S / GAC Z) .....	52-64
---	-------

## Rod End

COM/HCOM .....	65
Steel on Bronze (SIBP / SABP / SAZP / SIZP) .....	66-69
Steel on Steel (SIZJ / SAZJ) .....	70-71

<b>Bearing Kits - Trailer and Snowmobile Bearings</b> .....	72
---	----

<b>Hvac Bearings</b> (RCR & LRCR / RABR) .....	73
--	----

<b>Mast Guide Bearings</b> .....	74-77
----------------------------------	-------

<b>Solid Shaft Collar</b> .....	78-79
---------------------------------	-------

## Engineering

Bearing Tolerances .....	80-83
Fit Charts .....	84
Trust Bearing Fits .....	85
Needle Roller Bearing Fits .....	85
Ball Bearing Fits .....	87
Technical Data .....	88
Grease Charts .....	89
Conversion Formulas .....	90
Heavy Duty Needle Bearings .....	91
Rod Ends .....	92-94
Radial Spherical Plain Bearings .....	95-101
Angular Contact Spherical Plain .....	102-104



# Miniature & Instrument Ball Bearings

## Metric Series

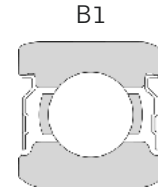
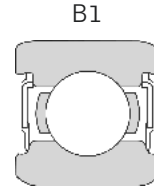
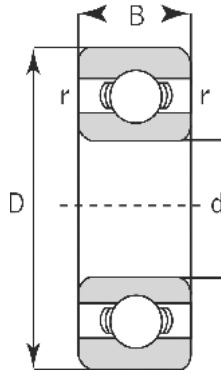

Miniature

2RS

ZZ

Unit No.	Bore (mm) d	Outer Diameter (mm) D	Width (mm)		Radius (mm) r, r1	Basic Load Rating (lbs)		Weight (lbs)
			Open B	ZZ / 2RS B1		Dynamic Cr	Static C0r	
681	1	3	1	-	0.05	18	5	0.001
MR 31	1	3	1.5	-	0.05	18	5	0.001
691	1	4	1.6	-	0.1	24	8	0.001
MR 41X	1.2	4	1.8	2.5	0.1	24	8	0.001
681X	1.5	4	1.2	2	0.05	20	7	0.001
691X	1.5	5	2	2.6	0.15	29	11	0.001
601X	1.5	6	2.5	3	0.15	55	22	0.001
682	2	5	1.5	2.3	0.08	29	11	0.001
MR 52	2	5	2	2.5	0.1	37	11	0.001
692	2	6	2.3	3	0.15	55	22	0.001
MR 62	2	6	2.5	2.5	0.15	60	22	0.001
MR 72	2	7	2.5	3	0.15	65	26	0.001
602	2	7	2.8	3.5	0.15	66	29	0.001
682X	2.5	6	1.8	2.6	0.08	35	14	0.001
692X	2.5	7	2.5	3.5	0.15	66	29	0.001
MR 82X	2.5	8	2.5	-	0.2	64	24	0.001
602X	2.5	8	2.8	4	0.15	64	24	0.001
MR 63	3	6	2	2.5	0.1	35	14	0.001
683	3	7	2	3	0.1	66	29	0.001
MR 83	3	8	2.5	3	0.15	64	24	0.001
693	3	8	3	4	0.15	64	24	0.001
MR 93	3	9	2.5	4	0.2	70	30	0.001

# Miniature & Instrument Ball Bearings

## Metric Series

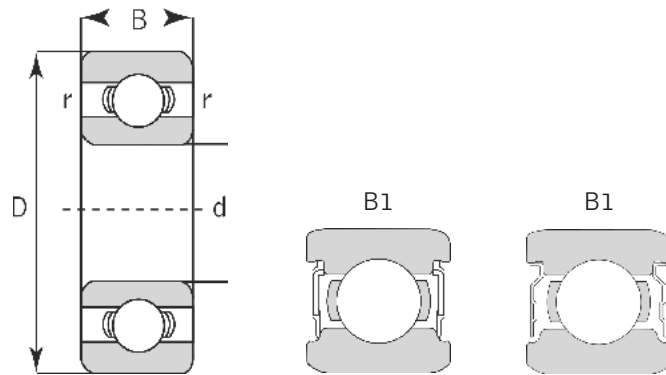

Miniature

2RS

ZZ

Unit No.	Bore (mm) d	Outer Diameter (mm) D	Width (mm)		Radius (mm) r, r1	Basic Load Rating (lbs)		Weight (lbs)
			Open B	ZZ / 2RS B1		Dynamic Cr	Static C0r	
633	3	13	5	5	0.2	266	98	0.005
MR 74	4	7	2	2.5	0.1	58	25	0.001
MR 84	4	8	2	3	0.15	88	33	0.001
684	4	9	2.5	4	0.1	99	42	0.001
MR 104	4	10	3	4	0.2	99	42	0.002
694	4	11	4	4	0.15	123	57	0.004
604	4	12	4	4	0.2	167	77	0.005
624	4	13	5	5	0.2	224	108	0.007
634	4	16	5	5	0.3	300	140	0.013
MR 85	5	8	2	2.5	0.1	62	31	0.001
MR 95	5	9	2.5	3	0.15	112	46	0.001
MR 105	5	10	3	4	0.15	115	55	0.002
MR 115	5	11	3	4	0.15	123	57	0.002
685	5	11	3	5	0.15	123	57	0.003
695	5	13	4	4	0.2	187	90	0.005
605	5	14	5	5	0.2	229	110	0.007
625	5	16	5	5	0.3	300	140	0.01
635	5	19	6	6	0.3	400	190	0.017
MR 106	6	10	2.5	3	0.15	123	57	0.001
MR 126	6	12	3	4	0.2	187	82	0.002
686	6	13	3.5	5	0.15	187	90	0.004
696	6	15	5	5	0.2	300	140	0.009
606	6	17	6	6	0.3	300	140	0.013
626	6	19	6	6	0.3	400	190	0.017
636	6	22	7	7	0.3	670	280	0.03
MR 117	7	11	2.5	3	0.15	101	46	0.001



# Miniature & Instrument Ball Bearings

## Metric Series

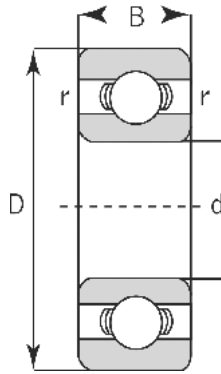

Miniature

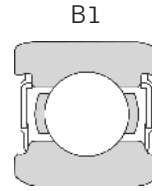

2RS

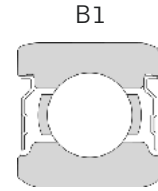

ZZ

Unit No.	Bore (mm) d	Outer Diameter (mm) D	Width (mm)		Radius (mm) r, r1	Basic Load Rating (lbs)		Weight (lbs)
			Open B	ZZ / 2RS B1		Dynamic Cr	Static C0r	
697	7	17	5	5	0.3	235	120	0.012
607	7	19	6	6	0.3	385	190	0.018
627	7	22	7	7	0.3	580	290	0.024
637	7	26	9	9	0.3	820	330	0.053
MR 128	8	12	2.5	3.5	0.15	115	57	0.001
MR 148	8	14	3.5	4	0.2	198	88	0.003
688	8	16	4	5	0.2	310	160	0.007
698	8	19	6	6	0.3	285	145	0.014
X 117	8	22	6	6	0.3	580	290	0.02
608	8	22	7	7	0.3	580	290	0.024
628	8	24	8	8	0.3	690	350	0.026
638	8	28	9	9	0.3	1012	440	0.056
689	9	17	4	5	0.2	310	143	0.013
699	9	20	6	6	0.3	528	231	0.017
609	9	24	7	7	0.3	580	280	0.026
629	9	26	8	8	0.3	790	400	0.04
639	9	30	10	10	0.6	1045	462	0.07

# Miniature & Instrument Ball Bearings

## Metric Flanged Series

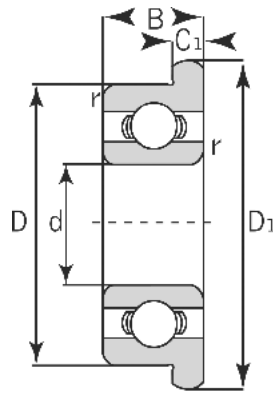

Miniature Flanged

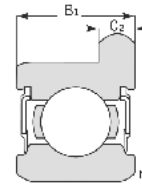

2RS

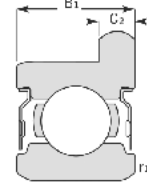

ZZ

Unit No.	Bore (mm)	Outer Diameter (mm)		Flange Width (mm)		Width (mm)		Radius (mm)	Basic Load Rating (lbs)		Weight (lbs)
	d	D	D1	C1	C2	Open B	Shielded B1	r, r1	Dynamic Cr	Static Cor	
F 681	1	3	3.8	0.3	-	1	-	0.05	18	5	0.001
F 691	1	4	5	0.5	-	1.6	-	0.1	24	9	0.001
MF 41X	1.2	4	4.8	0.4	-	1.8	2.5	0.1	24	9	0.001
F 681X	1.5	4	5	0.4	-	1.2	2	0.05	20	7	0.001
F 691X	1.5	5	6.5	0.6	0.8	2	2.6	0.15	29	11	0.001
F 601X	1.5	6	7.5	0.6	0.8	2.5	3	0.15	55	22	0.001
F 682	2	5	6.1	0.5	0.6	1.5	2.3	0.08	29	11	0.001
MF 52	2	5	6.2	0.6	0.6	2	2.5	0.1	29	11	0.001
F 692	2	6	7.5	0.6	0.8	2.3	3	0.15	55	22	0.001
MF 62	2	6	7.2	0.6	-	2.5	2.5	0.15	55	22	0.001
MF 72	2	7	8.2	0.6	0.6	2.5	3	0.15	66	29	0.001
F 602	2	7	8.5	0.7	0.9	2.8	3.5	0.15	66	29	0.001
F 682X	2.5	6	7.1	0.5	0.8	1.8	2.6	0.08	35	14	0.001
F 692X	2.5	7	8.5	0.7	0.9	2.5	3.5	0.15	66	29	0.001
MF 82X	2.5	8	9.2	0.6	-	2.5	-	0.2	46	17	0.001
F 602X	2.5	8	9.5	0.7	0.9	2.8	4	0.15	64	24	0.001
MF 63	3	6	7.2	0.6	0.6	2	2.5	0.1	34	14	0.001
F 683	3	7	8.1	0.5	0.8	2	3	0.1	66	29	0.001
MF 83	3	8	9.2	0.6	-	2.5	-	0.15	64	24	0.001
F 693	3	8	9.5	0.7	0.9	3	4	0.15	64	24	0.001
MF 93	3	9	10.2*	0.6	0.8	2.5	4	0.2	99	42	0.001
F 603	3	9	10.5	0.7	-	3	-	0.15	99	42	0.002
F 623	3	10	11.5	1	1	4	4	0.15	99	42	0.004
MF 74	4	7	8.2	0.6	0.6	2	2.5	0.1	58	25	0.001
MF 84	4	8	9.2	0.6	0.6	2	3	0.15	88	33	0.001
F 684	4	9	10.3	0.6	1	2.5	4	0.1	99	42	0.001
MF 104	4	10	11.2*	0.6	0.8	3	4	0.2	99	42	0.002
F 694	4	11	12.5	1	1	4	4	0.15	123	57	0.004
F 604	4	12	13.5	1	1	4	4	0.2	167	77	0.005
F 624	4	13	15	1	1	5	5	0.2	224	108	0.006
F 634	4	16	18	1	1	5	5	0.3	300	140	0.012

Other sizes could be available upon request. Minimum quantity may apply.

\*Flange Diameter 0.4mm greater for shielded bearings.

2RS stands for "Double Rubber Seals".

ZZ stands for "Shielded".



# Miniature & Instrument Ball Bearings

## Metric Flanged Series

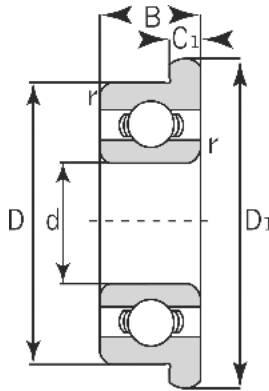

Miniature Flanged

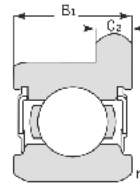

2RS

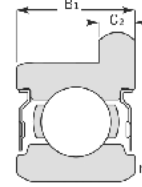

ZZ

Unit No.	Bore	Outer Diameter		Flange Width		Width		Radius	Basic Load Rating		Weight (lbs)
	(mm)	(mm)		(mm)		(mm)		(mm)	(lbs)		
	d	D	D1	C1	C2	Open B	Shielded B1	r, r1	Dynamic Cr	Static Cor	
MF 105	5	10	11.2*	0.6	0.8	3	4	0.15	115	55	0.002
MF 115	5	11	12.6	-	0.8	-	4	0.15	123	57	0.002
F 685	5	11	12.5	0.8	1	3	5	0.15	123	57	0.002
F 695	5	13	15	1	1	4	4	0.2	187	90	0.005
F 605	5	14	16	1	1	5	5	0.2	229	110	0.007
F 625	5	16	18	1	1	5	5	0.3	300	140	0.017
F 635	5	19	22	1.5	1.5	6	6	0.3	400	190	0.018
MF 106	6	10	11.2	0.6	0.6	2.5	3	0.15	123	57	0.001
MF 126	6	12	13.2*	0.6	0.8	3	4	0.2	187	82	0.002
F 686	6	13	15	1	1.1	3.5	5	0.15	187	90	0.004
F 696	6	15	17	1.2	1.2	5	5	0.2	300	140	0.009
F 606	6	17	19	1.2	1.2	6	6	0.3	300	140	0.013
F 626	6	19	22	1.5	1.5	6	6	0.3	400	190	0.018
MF 117	7	11	12.2	0.6	0.06	2.5	3	0.15	101	46	0.001
MF 137	7	13	14.2*	0.6	0.8	3	4	0.2	198	88	0.003
F 687	7	14	16	1	1.1	3.5	5	0.15	202	103	0.005
F 697	7	17	19	1.2	1.2	5	5	0.3	235	120	0.011
F 607	7	19	22	1.5	1.5	6	6	0.3	385	180	0.017
F 627	7	22	25	1.5	1.5	7	7	0.3	580	290	0.028
MF 128	8	12	13.2*	0.6	0.8	2.5	3.5	0.15	115	57	0.001
MF 148	8	14	15.6	0.8	0.8	3.5	4	0.2	198	88	0.004
F 688	8	16	18	1	1.1	4	5	0.2	310	160	0.007
F 698	8	19	22	1.5	1.5	6	6	0.3	285	145	0.016
F 608	8	22	25	1.5	1.5	7	7	0.3	580	290	0.026
F 689	9	17	19	1	1.1	4	5	0.2	310	143	0.007
F 699	9	20	23	1.5	1.5	6	6	0.3	528	231	0.018
F 609	9	24	27	1.5	1.5	7	7	0.3	580	290	0.02



# Miniature & Instrument Ball Bearings

Inch Series

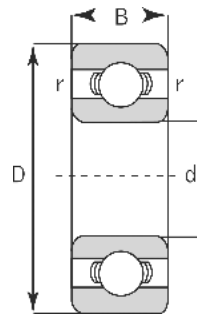

R

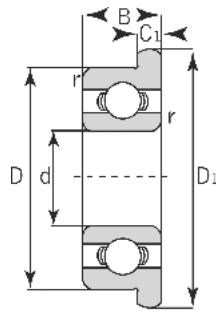

FR

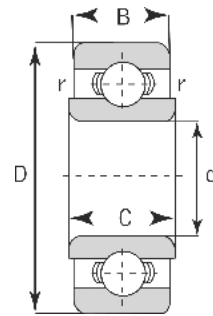

R-EE

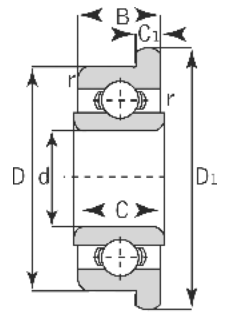

FR-EE

Unit No.	Bore		Outer Diameter		Width				Flange Dimensions		Radius	Basic Load Rating (lbs)		Weight (lbs)
	fract.	(inch)	fract.	(inch)	Open	ZZ / 2RS	Open	ZZ / 2RS	Open		(inch)	Dynamic Cr	Static COr	
	d		D		B		C		d1	c1	r			
R 09	1/25	0.0400	1/8	0.2500	0.0469	-	-	-	-	-	0.004	22	6	0.001
R 0	3/64	0.0469	5/32	0.1562	0.0625	0.0937	0.0937	0.125	0.203	0.013	0.004	36	10	0.001
R 1	-	0.055	3/16	0.1875	0.0781	0.1094	0.1094	0.1406	0.234	0.023	0.004	42	13	0.001
R 1-4	5/64	0.0781	1/4	0.25	0.0937	0.1406	0.125	0.1719	0.296	0.023	0.004	63	20	0.001
R 133	3/32	0.0937	3/16	0.1875	0.0625	0.0937	0.0937	0.125	0.234	0.018	0.004	28	9.5	0.001
R 1-5	3/32	0.0937	5/16	0.3125	0.1094	0.1406	0.1406	0.1719	0.359	0.023	0.006	96	34	0.001
R 144	1/8	0.125	1/4	0.25	0.0937	0.1094	0.125	0.1406	0.296	0.023	0.004	64	22	0.001
R 2-5	1/8	0.125	5/16	0.3125	0.1094	0.1406	0.1406	0.1719	0.359	0.023	0.004	26	40	0.002
R 2-6	1/8	0.125	3/8	0.375	0.1094	0.1406	0.1406	0.1719	0.422	0.023	0.006	44	50	0.002
R 2	1/8	0.125	3/8	0.375	0.1562	0.1562	0.1875	0.1875	0.44	0.03	0.012	44	50	0.003
R 2A	1/8	0.125	1/2	0.5	0.1719	0.1719	-	-	-	-	0.012	58	89	0.007
R 155	5/32	0.1562	5/16	0.3125	0.1094	0.125	0.1406	0.1562	0.359	0.023	0.004	76	30	0.001
R 156	3/16	0.1875	5/16	0.3125	0.1094	0.125	0.1406	0.1562	0.359	0.023	0.004	89	32	0.001
R 166	3/16	0.1875	3/8	0.375	0.1250	0.125	0.1562	0.1562	0.422	0.023	0.004	160	60	0.002
R 3	3/16	0.1875	1/2	0.5	0.1562	0.196	0.2272	0.2272	0.565	0.042	0.012	295	110	0.005
R 3A	3/16	0.1875	1/2	0.5	0.196	0.196	-	-	-	-	0.012	295	110	0.006
R 168	1/4	0.25	3/8	0.375	0.125	0.125	0.1562	0.1562	0.422	0.023	0.004	60	31	0.001
R 188	1/4	0.25	1/2	0.5	0.125	0.1875	0.1562	0.2188	0.547	0.023	0.006	186	84	0.004
R 4	1/4	0.25	5/8	0.625	0.196	0.196	0.2272	0.2272	0.69	0.042	0.012	235	139	0.01
R 4A	1/4	0.25	3/4	0.75	0.2188	0.2812	-	-	-	-	0.016	525	199	0.017



# Miniature & Instrument Ball Bearings

Inch series

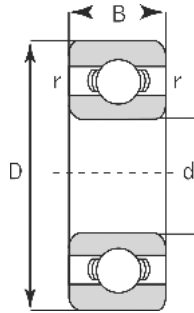

R

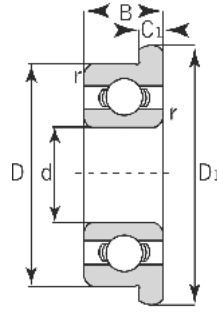

FR

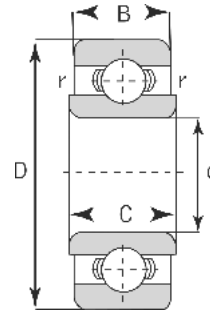

R-EE

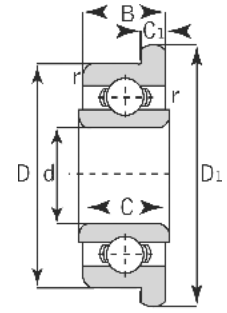

FR-EE

Unit No.	Bore		Outer Diameter		Width				Flange Dimensions		Radius	Basic Load Rating (lbs)		Weight (lbs)
	fract.	(inch)	fract.	(inch)	Open	ZZ / 2RS	Open	ZZ / 2RS	Open		(inch)	Dynamic Cr	Static C0r	
	d		D		B		C		d1	c1	r			
R 1238	3/8	0.375	3/4	0.75	0.196	0.196	-	-	-	-	0.01	385	189	0.001
R 6	3/8	0.375	7/8	0.875	0.2188	0.2812	-	-	0.969	0.062	0.016	745	315	0.024
R 1212	1/2	0.5	3/4	0.75	0.1562	0.1562	-	-	-	-	0.01	200	114	0.001
R 1412	1/2	0.5	7/8	0.875	0.196	0.196	-	-	-	-	0.01	422	222	0.001
R 8	1/2	0.5	1-1/8	1.125	0.25	0.3125	-	-	1.225	0.062	0.016	1148	535	0.039
R 1458	5/8	0.625	7/8	0.875	0.1562	0.1562	-	-	-	-	0.01	202	130	0.001
R 1658	5/8	0.625	1	1	0.196	0.196	-	-	-	-	0.01	462	295	0.001
R 10	5/8	0.625	1-3/8	1.375	0.2812	0.3438	-	-	-	-	0.031	1347	734	0.081
R 1634	3/4	0.75	1	1	0.1562	0.1562	-	-	-	-	0.01	216	139	0.001
R 1834	3/4	0.75	1-1/8	1.125	0.2812	0.2812	-	-	-	-	0.016	225	154	0.001
R 12	3/4	0.75	1-5/8	1.625	0.3125	0.4375	-	-	-	-	0.031	1770	1018	0.104
R 14	7/8	0.875	1-7/8	1.875	0.375	0.5	-	-	-	-	0.031	2261	1316	0.157
R 16	1	1	2	2	0.375	0.5	-	-	-	-	0.031	2261	1316	0.187
R 18	1-1/8	1.125	2-1/8	2.125	0.375	0.5	-	-	-	-	0.031	2150	1407	0.198
R 20	1-1/4	1.25	2-1/4	2.25	0.375	0.5	-	-	-	-	0.031	2973	1858	0.209
R 22	1-3/8	1.375	2-1/2	2.5	0.4375	0.5625	-	-	-	-	0.031	2756	1910	0.232
R 24	1-1/2	1.5	2-5/8	2.625	0.4375	0.5626	-	-	-	-	0.031	2906	2084	0.309

# Single Row Radial Ball Bearings

Inch series 1600

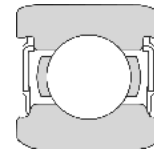
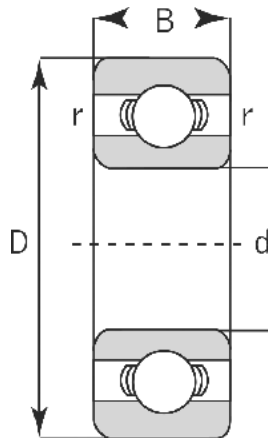

2RS

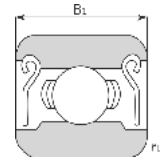

ZZ

Unit No.	Bore		Outer Diameter		Width		Radius (inch)	Basic Load Rating (lbs)		Weight (lbs)
	fract.	(inch)	fract.	(inch)	fract.	(inch)		Dynamic Cr	Static COr	
	d		D		W		r			
1601	3/16	0.1875	11/16	0.6875	1/4*	0.25*	0.012	350	167	0.012
1602	1/4	0.25	11/16	0.6875	1/4*	0.25*	0.012	350	167	0.013
1603	5/16	0.3125	7/8	0.8750	9/32**	0.2812**	0.012	686	310	0.023
1604	3/8	0.375	7/8	0.8750	9/32**	0.2812**	0.015	686	310	0.021
1605	5/16	0.3125	29/32	0.9062	5/16	0.3125	0.012	725	318	0.032
1606	3/8	0.375	29/32	0.9062	5/16	0.3125	0.015	725	318	0.030
1607	7/16	0.4375	29/32	0.9062	5/16	0.3125	0.015	725	318	0.035
1614	3/8	0.375	1-1/8	1.125	3/8	0.375	0.025	885	501	0.077
1615	7/16	0.4375	1-1/8	1.125	3/8	0.375	0.025	885	501	0.071
1616	1/2	0.5	1-1/8	1.125	3/8	0.375	0.025	885	501	0.066
1620	7/16	0.4375	1-3/8	1.375	7/16	0.4375	0.025	1038	626	0.105
1621	1/2	0.5	1-3/8	1.375	7/16	0.4375	0.025	1038	626	0.106
1622	9/16	0.5625	1-3/8	1.375	7/16	0.4375	0.025	1038	626	0.101
1623	5/8	0.625	1-3/8	1.375	7/16	0.4375	0.025	1038	626	0.088
1628	5/8	0.625	1-5/8	1.625	1/2	0.5	0.025	1848	1055	0.159
1630	3/4	0.75	1-5/8	1.625	1/2	0.5	0.025	1848	1055	0.143
1633	5/8	0.625	1-3/4	1.75	1/2	0.5	0.025	1848	1055	0.203
1635	3/4	0.75	1-3/4	1.75	1/2	0.5	0.025	1848	1055	0.187
1638	3/4	0.75	2	2	9/16	0.5625	0.035	1958	1165	0.265
1640	7/8	0.875	2	2	9/16	0.5625	0.035	1958	1165	0.247
1641	1	1	2	2	9/16	0.5625	0.035	1958	1165	0.221
1652	1-1/8	1.125	2-1/2	2.5	5/8	0.625	0.035	2592	1735	0.463
1654	1-1/4	1.25	2-1/2	2.5	5/8	0.625	0.035	2592	1735	0.419
1657	1-1/4	1.25	2-9/16	2.5625	11/16	0.6875	0.035	3362	2244	0.474
1658	1-5/16	1.3125	2-9/16	2.5625	11/16	0.6875	0.035	3362	2244	0.441

Other sizes could be available upon request. Minimum quantity may apply.

\*Width 5/16 inch for RS, 2RS

\*\*Width 11/32 inch for RS, 2RS, Z & ZZ

2RS stands for "Double Rubber Seals".

ZZ stands for "Shielded".



# Single Row Radial Ball Bearings

## Metric Series

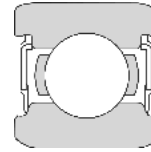
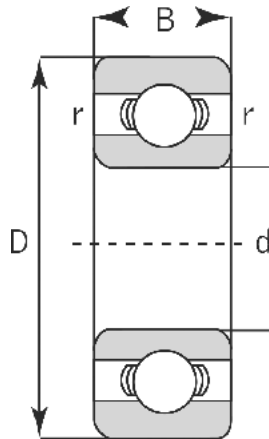

2RS

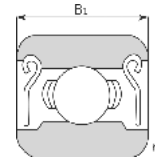

ZZ

### 16000

Unit No.	Bore (mm)	Outer Diameter (mm)	Width (mm)	Basic Load Rating (lbs)		Weight (lbs)
	d	D	B	Dynamic Cr	Static Cor	
16100	10	28	8	1178	545	0.05
16001	12	28	7	1144	530	0.042
16101	12	30	8	1201	557	0.055
16002	15	32	8	1260	641	0.06
16003	17	35	8	1360	731	0.065
16004	20	42	8	1550	910	0.105
16005	25	47	8	1710	1070	0.115
16006	30	55	9	2520	1650	0.175
16007	35	62	9	2790	1830	0.185
16008	40	68	9	2990	2060	0.27
16009	45	75	10	3344	2552	0.367
16010	50	80	10	3454	2772	0.385
16011	55	90	11	4356	3652	0.565
16012	60	95	11	4488	3916	0.618
16013	65	100	11	4598	4202	0.66
16014	70	110	13	6006	5302	0.961
16015	75	115	13	6204	5676	1.019

### 6700

Unit No.	Bore (mm)	Outer Diameter (mm)	Width (mm)	Basic Load Rating (lbs)		Weight (lbs)
	d	D	B	Dynamic Cr	Static Cor	
6701	12	18	4	207	119	0.006
6702	15	21	4	211	130	0.007
6703	17	23	4	224	147	0.008
6704	20	27	4	233	163	0.012
6705	25	32	4	242	187	0.014
6706	30	37	4	253	209	0.016
6707	35	44	5	418	363	0.030
6708	40	50	6	550	495	0.046
6709	45	55	6	583	539	0.050

# Single Row Radial Ball Bearings

## Metric Series

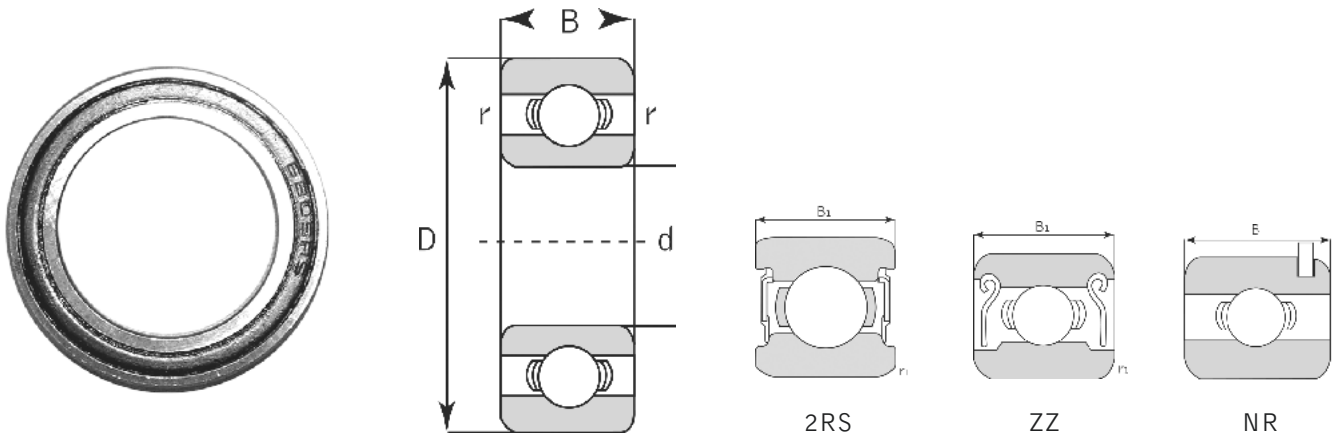

### 6800

Unit No.	Bore (mm)	Outer Diameter (mm)	Width (mm)	Radius (mm)	Basic Load Rating (lbs)		Weight (lbs)
	d	D	B	r	Dynamic Cr	Static C0r	
6800	10	19	5	0.5	328	156	0.005
6801	12	21	5	0.5	344	176	0.006
6802	15	24	5	0.5	372	212	0.007
6803	17	26	5	0.5	504	289	0.008
6804	20	32	7	0.5	720	416	0.019
6805	25	37	7	0.5	772	499	0.022
6806	30	42	7	0.5	848	611	0.026
6807	35	47	7	0.5	880	679	0.029
6808	40	52	7	0.5	912	739	0.033
6809	45	58	7	0.5	1135	953	0.04
6810	50	65	7	0.5	1184	1028	0.052
6811	55	72	9	0.5	1584	1365	0.083
6812	60	78	10	0.5	2064	1785	0.106

### 6900

Unit No.	Bore (mm)	Outer Diameter (mm)	Width (mm)	Radius (mm)	Basic Load Rating (lbs)		Weight (lbs)
	d	D	B	r	Dynamic Cr	Static C0r	
6901	12	24	6	0.5	520	248	0.011
6902	15	28	7	0.5	736	345	0.016
6903	17	30	7	0.5	840	435	0.018
6904	20	37	9	0.5	1144	619	0.036
6905	25	42	9	0.5	1264	765	0.042
6906	30	47	9	0.5	1304	848	0.048
6907	35	55	10	1	2008	1253	0.074
6908	40	62	12	1	912	739	0.11
6909	45	68	12	1	2720	1898	0.128
6910	50	72	12	1	2800	2063	0.132
6911	55	80	13	1.5	2880	2235	0.18
6912	60	85	13	1.5	2960	2400	0.193



# Single Row Radial Ball Bearings

Metric series

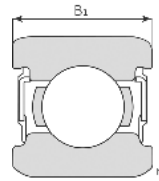
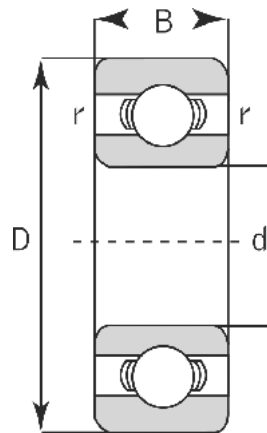

2RS

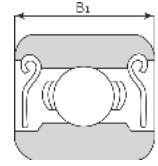

ZZ

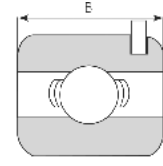

NR

## 6000

Unit No.	Bore (mm)	Outer Diameter (mm)	Width (mm)	Radius (mm)	Basic Load Rating (lbs)		Weight (lbs)
	d	D	B	r	Dynamic Cr	Static Cor	
6000	10	26	8	0.5	1030	440	0.042
6001	12	28	8	0.5	1150	540	0.049
6002	15	32	9	0.5	1260	635	0.066
6003	17	35	10	0.5	1530	755	0.086
6004	20	42	12	1	2110	1140	0.152
60/22	22	44	12	1	2110	1150	0.163
6005	25	47	12	1	2260	1320	0.176
60/28	28	52	12	1	2800	1660	0.216
6006	30	55	13	1.5	2970	1860	0.256
60/32	32	58	13	1.5	3400	2050	0.284
6007	35	62	14	1.5	3600	2310	0.342
6008	40	68	15	1.5	3750	2590	0.423
6009	45	75	16	1.5	4700	3400	0.54
6010	50	80	16	1.5	4900	3750	0.575
6011	55	90	18	1.5	6350	4800	0.849
6012	60	95	18	2	6600	5200	0.915
6013	65	100	18	2	6850	5650	0.959
6014	70	110	20	2	8550	6950	1.33
6015	75	115	20	2	8900	7550	1.41
6016	80	125	22	2	10700	8950	1.87
6017	85	130	22	2	11100	9700	1.96
6018	90	140	24	2.5	13100	11200	2.56
6019	95	145	24	2.5	13600	12100	2.67
6020	100	150	24	2.5	13500	12200	2.76

# Single Row Radial Ball Bearings

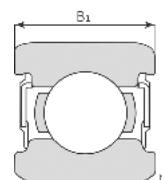
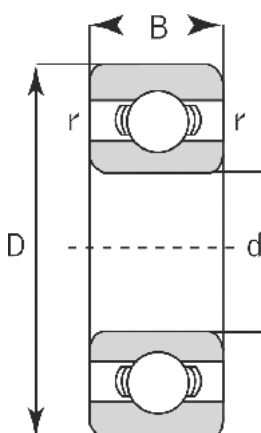

2RS

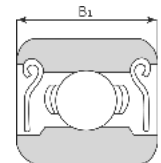

ZZ

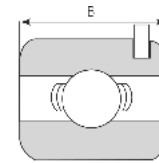

NR

## 6200

Unit No.	Bore (mm)	Outer Diameter (mm)	Width (mm)	Radius (mm)	Basic Load Rating (lbs)		Weight (lbs)
	d	D	B	r	Dynamic Cr	Static Cor	
6201	12	32	10	1	1370	615	0.082
6201-8	12.7	32	10	1	1370	615	0.082
6201-13mm	13	32	10	1	1370	615	0.082
6202	15	35	11	1	1740	805	0.099
6202-8	12.7	35	11	1	1740	805	0.110
6202-10	15.875	35	11	1	1740	805	0.090
6202-16mm	16	35	11	1	1740	805	0.090
6203	17	40	12	1	2160	1030	0.143
6203-8	12.7	40	12	1	2160	1030	0.154
6203-10	15.875	40	12	1	2160	1030	0.150
6203-16mm	16	40	12	1	2160	1030	0.150
6203-12	19.05	40	12	1	2160	1030	0.140
6204	20	47	14	1.5	2890	1500	0.234
6204-12	19.05	47	14	1.5	2890	1500	0.236
62/22	22	50	14	1.5	2900	1530	0.258
6204-14	22.225	47	14	1.5	2890	1500	0.230
6205	25	52	15	1.5	3150	1770	0.282
6205-16	25.4	52	15	1.5	3150	1770	0.280
62/28	28	58	16	1.5	4000	2190	0.377
6206	30	62	16	1.5	4400	2540	0.439
62/32	32	65	17	1.5	4625	2600	0.498
6207	35	72	17	2	5750	3450	0.635
6208	40	80	18	2	6550	4000	0.807
6209	45	85	19	2	7350	4600	0.897
6210	50	90	20	2	7900	5200	1.02
6211	55	100	21	2.5	9750	6550	1.34
6212	60	110	22	2.5	11800	8150	1.73
6213	65	120	23	2.5	12900	9000	2.18
6214	70	125	24	2.5	14000	9900	2.36
6215	75	130	25	2.5	14900	11100	2.60
6216	80	140	26	3	16300	11900	3.09
6217	85	150	28	3	18700	14300	3.95
6218	90	160	30	3	21600	16100	4.74
6219	95	170	32	3.5	24500	18400	5.78
6220	100	180	34	3.5	27500	20900	6.92



# Single Row Radial Ball Bearings

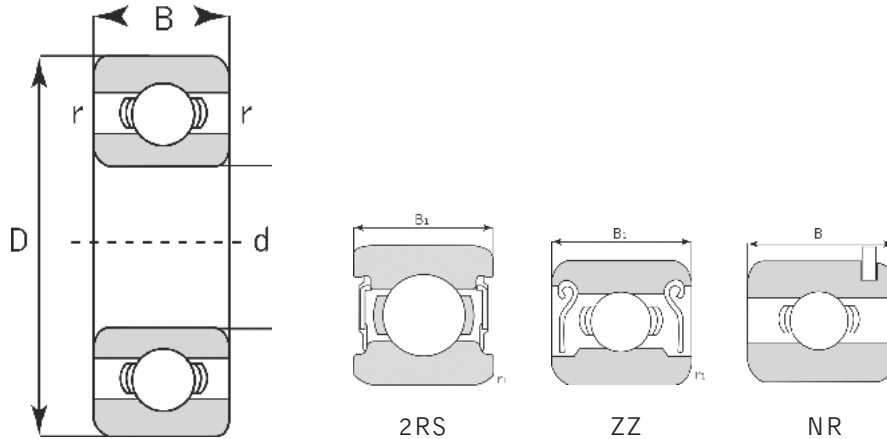

## 6300

Unit No.	Bore (mm)	Outer Diameter (mm)	Width (mm)	Radius (mm)	Basic Load Rating (lbs)		Weight (lbs)
	d	D	B	r	Dynamic Cr	Static Cor	
6301	12	37	12	1.5	2180	940	0.132
6302	15	42	13	1.5	2570	1220	0.181
6303	17	47	14	1.5	3050	1470	0.254
6304	20	52	15	2	3600	1770	0.317
63/22	22	56	16	2	4100	2080	0.511
6305	25	62	17	2	4750	2460	0.511
6305-16	25.4	62	17	2	4750	2460	0.511
63/28	28	68	18	2	6000	3150	0.633
6306	30	72	19	2	6700	3800	0.763
6306-20	31.75	72	19	2	6700	3800	0.749
63/32	32	75	20	2	23000	16000	0.842
6307	35	80	21	2.5	7500	4300	1.01
6308	40	90	23	2.5	9150	5400	1.4
6309	45	100	25	2.5	11900	7200	1.84
6310	50	110	27	3	13900	8600	2.36
6311	55	120	29	3	16100	10100	3.02
6312	60	130	31	3.5	18400	11700	3.75
6313	65	140	33	3.5	20800	13400	4.59
6314	70	150	35	3.5	23400	15300	5.56
6315	75	160	37	3.5	25500	17400	6.66
6316	80	170	39	3.5	27600	19500	7.91
6317	85	180	41	4	29800	21800	9.33
6318	90	190	43	4	32000	24100	10.8
6319	95	200	45	4	34500	26600	12.5
6320	100	215	47	4	39000	31500	15.4

## 6400

Unit No.	Bore (mm)	Outer Diameter (mm)	Width (mm)	Radius (mm)	Basic Load Rating (lbs)		Weight (lbs)
	d	D	B	r	Dynamic Cr	Static Cor	
6404	20	72	19	1.0	6400	3150	0.90
6405	25	80	21	1.5	4750	2460	1.19
6406	30	90	23	1.5	9750	5350	1.59
6407	35	100	25	1.5	12400	7000	2.06
6408	40	110	27	2.0	14300	8200	2.69
6409	45	120	29	2.0	17300	10100	3.41
6410	50	130	31	2.0	18700	11100	4.20



# Single Row Radial Ball Bearings

## Maximum-Capacity Type-Series

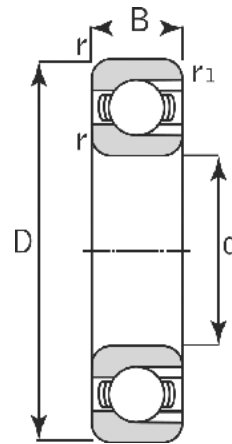

### BL200

Unit No.	Bore (mm)	Outer Diameter (mm)	Width (mm)	Radius (mm)	Limiting Speed (rpm)		Basic Load Rating (lbs)		Weight (lbs)
	d	D	B	r	ZZ	2RS	Dynamic Cr	Static Cor	
BL 205	25	52	15	1.5	12.000	9.000	3.800	2.360	0.312
BL 206	30	62	16	1.5	10.000	7.500	5.600	3.650	0.471
BL 207	35	72	17	2	8.800	6.600	7.400	4.950	0.700
BL 208	40	80	18	2	7.800	5.850	8.800	6.250	0.880
BL 209	45	85	19	2	7.000	5.250	9.900	7.150	1.000
BL 210	50	90	20	2	6.400	4.800	10.300	7.850	1.100
BL 211	55	100	21	2.5	5.800	4.350	12.800	9.850	1.500
BL 212	60	110	22	2.5	5.400	4.050	15.500	12.200	1.900
BL 213	65	120	23	2.5	4.900	3.675	16.900	13.500	2.400
BL 214	70	125	24	2.5	4.600	3.450	18.300	14.900	2.600
BL 215	75	130	25	2.5	4.300	3.225	19.100	16.100	2.790

### BL300

Unit No.	Bore (mm)	Outer Diameter (mm)	Width (mm)	Radius (mm)	Limiting Speed (rpm)		Basic Load Rating (lbs)		Weight (lbs)
	d	D	B	r	ZZ	2RS	Dynamic Cr	Static Cor	
BL 305	26	62	17	2	11.000	8.250	6.050	3.500	0.568
BL 306	30	72	19	2	9.000	6.750	7.400	4.650	0.858
BL 307	35	80	21	2.5	7.900	5.925	9.800	6.450	1.100
BL 308	40	90	23	2.5	7.000	5.250	12.300	8.050	1.500
BL 309	45	100	25	2.5	6.300	4.725	14.700	9.900	2.100
BL 310	50	110	27	3	5.700	4.275	17.200	11.800	2.680
BL 311	55	120	29	3	5.200	3.900	21.100	15.200	3.410
BL 312	60	130	31	3	4.800	3.600	24.100	17.600	4.220
BL 313	65	140	33	3	4.400	3.300	27.300	20.200	5.190
BL 314	70	150	35	3	4.100	3.075	30.500	23.000	6.490
BL 315	75	160	37	3	3.800	2.850	33.500	26.000	7.920

Please contact us before hand to check availability of products.



# Double Row Ball Bearings

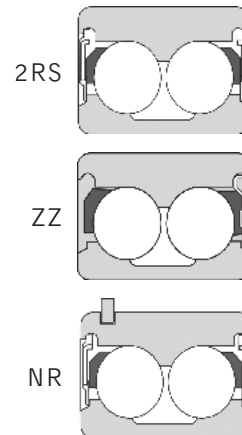
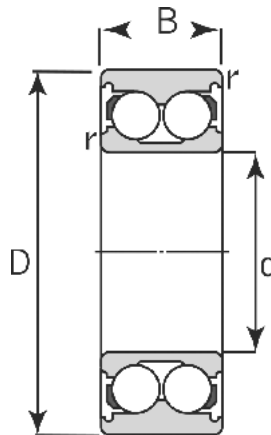

## 5200

Unit No.	Bore (mm)		Outer Diameter (mm)	Width (mm)	Radius (mm)	Basic Load Rating (lbs)		Weight (lbs)
	d	D				Dynamic Cr	Static Cor	
5200	10	30	14.287	0.8	1560	855	0.13	
5201	12	32	15.875	0.8	2050	1140	0.16	
5202	15	35	15.875	1	2260	1360	0.18	
5203	17	40	17.463	1	2870	1770	0.20	
5204	20	47	20.638	1.5	4300	2710	0.34	
5205	25	52	20.638	1.5	4650	3200	0.42	
5206	30	62	23.813	1.5	6450	4600	0.64	
5207	35	72	26.988	2	8500	6250	0.95	
5208	40	80	30.163	2	9600	7250	1.26	
5209	45	85	30.163	2	10800	8300	1.37	
5210	50	90	30.163	2	11500	9400	1.48	
5211	55	100	33.338	2.5	14200	11900	2.17	
5212	60	110	36.513	2.5	16100	13100	2.80	
5213	65	120	38.1	2.5	18700	16300	3.46	
5214	70	125	39.688	2.5	20400	17900	3.97	
5215	75	130	41.2175	2.5	20300	18100	4.20	
5216	80	140	44.45	3	23800	21400	5.50	
5217	85	150	49.213	3	25100	23900	6.75	
5218	90	160	52.388	3	31500	29000	8.90	

## 5300

Unit No.	Bore (mm)		Outer Diameter (mm)	Width (mm)	Radius (mm)	Basic Load Rating (lbs)		Weight (lbs)
	d	D				Dynamic Cr	Static Cor	
5301	12	37	19.05	1.1	1996	1389	0.23	
5302	15	42	19.05	1.5	3850	2260	0.38	
5303	17	47	22.225	1.5	4600	2720	0.49	
5304	20	52	22.225	2	4650	2850	0.51	
5305	25	62	25.4	2	6850	4600	0.75	
5306	30	72	30.163	2	8900	6200	1.13	
5307	35	80	34.925	2.5	11100	7850	1.74	
5308	40	90	36.513	2.5	13600	9850	2.32	
5309	45	100	39.688	2.5	16300	12100	3.10	
5310	50	110	44.45	3	19200	14500	4	
5311	55	120	49.213	3	23900	18500	5.11	
5312	60	130	53.975	3.5	27300	21400	6.72	
5313	65	140	58.738	3.5	31000	24600	8.60	
5314	70	150	63.5	3.5	35000	28000	10.80	
5315	75	160	68.263	3.5	38000	31500	12.10	
5316	80	170	68.263	3.5	42000	34500	15	

# Angular Contact Ball Bearings

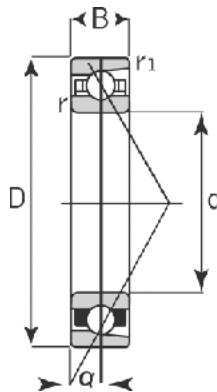
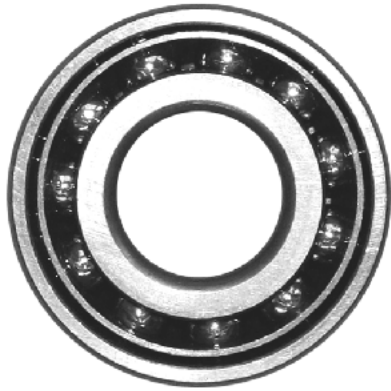

Contact Angle Suffix: C  $\alpha = 15^\circ$   
 A  $\alpha = 25^\circ$   
 B  $\alpha = 40^\circ$

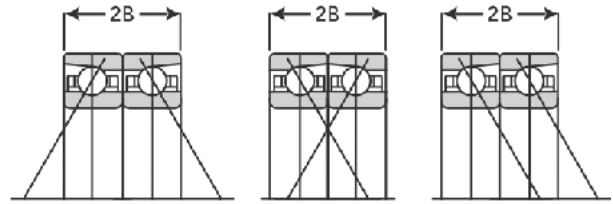

DB  
Back-to-Back  
Arrangement

DB  
Face-to-Face  
Arrangement

DT  
Tandem  
Arrangement

## 7200

Unit No.	Bore (mm)	Outer Diameter (mm)	Width (mm)	Radius (mm)		Load Center (mm)	Basic Load Rating (lbs)		Weight (lbs)
	d	D	B	r	r1		Dynamic Cr	Static Cor	
7200 B	10	30	9	1	0.5	13	1.120	0.565	0.640
7201 B	12	32	10	1	0.5	14	1.480	0.750	0.079
7202 B	15	35	11	1	0.5	16	1.880	0.980	0.101
7203 B	17	40	12	1	0.5	18	2.480	1.370	0.146
7204 B	20	47	14	1.5	0.8	21.5	2.990	1.730	0.225
7205 B	25	52	15	1.5	0.8	24	3.300	2.120	0.284
7206 B	30	62	16	1.5	0.8	27.5	4.600	3.050	0.434
7207 B	35	72	17	2	1.0	31	6.100	4.150	0.633
7208 B	40	80	18	1	1.0	34	7.200	5.150	0.827
7209 B	45	85	19	1	1.0	37	8.100	5.900	0.904
7210 B	50	90	20	1	1.0	39.5	8.400	6.450	1.030
7211 B	55	100	21	2.5	1.2	43	10.400	8.100	1.350
7212 B	60	110	22	2.5	1.2	47.5	12.600	10.000	1.720
7213 B	65	120	23	2.5	1.2	50.5	14.300	11.800	2.160
7214 B	70	125	24	2.5	1.2	53	15.500	13.000	2.450
7215 B	75	130	25	2.5	1.2	56	16.000	14.000	2.620
7216 B	80	140	26	3	1.5	59	18.100	15.600	3.130
7217 B	85	150	28	3	1.5	63.5	20.200	18.100	4.010
7218 B	90	160	30	3	1.5	67.5	24.000	21.100	4.890
7219 B	95	170	32	3.5	2.0	71.5	27.200	24.200	6.000
7220 B	100	180	34	3.5	2.0	76	29.300	25.700	7.190
7221 B	105	190	36	3.5	2.0	80	32.000	29.000	8.530
7222 B	110	200	38	3.5	2.0	84	34.500	32.500	10.000
7224 B	120	215	40	3.5	2.0	90.5	37.000	36.500	13.800
7226 B	130	230	40	4	2.0	95.5	40.000	40.500	15.800
7228 B	140	250	42	4	2.0	103	41.000	44.000	19.400
7230 B	150	270	45	4	2.0	111	47.000	53.000	24.300
7232 B	160	290	48	4	2.0	118	53.500	62.500	30.200
7234 B	170	310	52	4	2.0	127	60.000	73.500	37.500
7236 B	180	320	52	4	2.0	131	62.000	78.500	39.000
7238 B	190	340	55	4	2.0	139	61.500	79.500	47.000
7240 B	200	360	58	4	2.0	146	68.500	91.500	55.800



# Angular Contact Ball Bearings

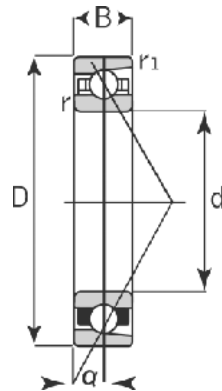
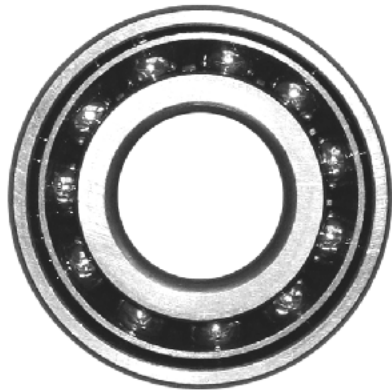

Contact Angle Suffix: C  $\alpha = 15^\circ$

A  $\alpha = 25^\circ$

B  $\alpha = 40^\circ$

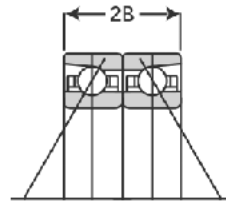

DB  
Back-to-Back  
Arrangement

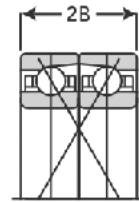

DB  
Face-to-Face  
Arrangement

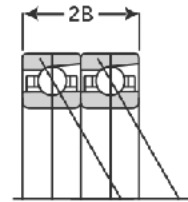

DT  
Tandem  
Arrangement

## 7300

Unit No.	Bore (mm)	Outer Diameter (mm)	Width (mm)	Radius (mm)		Load Center (mm)	Basic Load Rating (lbs)		Weight (lbs)
	d	D	B	r	r1		Dynamic Cr	Static Cor	
7301 B	12	37	12	1.5	0.8	16.5	2.370	1.110	0.099
7302 B	15	42	13	1.5	0.8	19	2.810	1.500	0.126
7303 B	17	47	14	1.5	0.8	20.5	3.350	1.800	0.240
7304 B	20	52	15	2	1.0	22.5	3.900	2.170	0.311
7305 B	25	62	17	2	1.0	27	5.500	3.300	0.516
7306 B	30	72	19	2	1.0	31.5	6.950	4.600	0.776
7307 B	35	80	21	2.5	1.2	34.5	8.250	5.450	1.030
7308 B	40	90	23	2.5	1.2	39	10.100	6.800	1.400
7309 B	45	100	25	2.5	1.2	43	13.100	9.050	1.880
7310 B	50	110	27	3	1.5	47	15.300	10.800	2.450
7311 B	55	120	29	3	1.5	52	17.700	12.800	3.130
7312 B	60	130	31	3.5	2.0	56	20.200	14.800	3.900
7313 B	65	140	33	3.5	2.0	59.5	22.900	17.000	4.720
7314 B	70	150	35	3.5	2.0	63.5	25.700	19.300	5.750
7315 B	75	160	37	3.5	2.0	68	28.000	21.900	6.900
7316 B	80	170	39	3.5	2.0	72	30.500	24.600	8.200
7317 B	85	180	41	4	2.0	76	32.500	27.400	9.770
7318 B	90	190	43	4	2.0	80.5	35.000	30.500	11.400
7319 B	95	200	45	4	2.0	84.5	37.500	33.500	13.200
7320 B	100	215	47	4	2.0	89.5	43.000	40.000	16.100
7321 B	105	225	49	4	2.0	93.5	45.500	43.500	18.400
7322 B	110	240	50	4	2.0	99	51.000	51.000	21.600
7324 B	120	260	55	4	2.0	107	50.500	52.000	32.400
7326 B	130	280	58	4	2.0	115	56.000	60.500	38.800
7328 B	140	300	62	4	2.0	123	62.000	69.500	47.400
7330 B	150	320	65	4	2.0	131	67.500	79.000	55.300
7332 B	160	340	68	4	2.0	139	71.000	87.000	65.700
7334 B	170	360	72	4	2.0	147	80.000	100.000	77.800
7336 B	180	380	75	4	2.0	155	84.000	110.000	90.200
7338 B	190	400	78	5	2.0	163	87.500	120.000	104.000
7340 B	200	420	80	5	2.0	170	92.000	125.000	117.000

# Single Direction Thrust Ball Bearing

## Metric Series

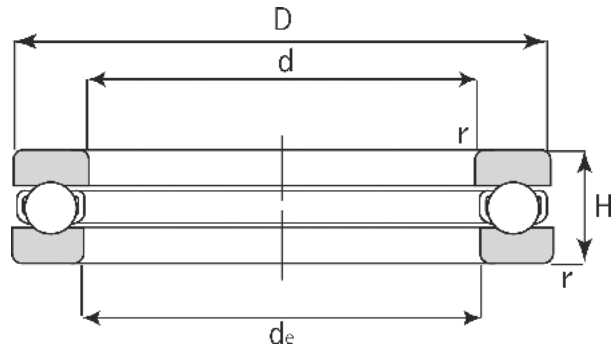

### 51100

Unit No.	Bore (mm)		Outer Diameter (mm)	Width (mm)	Basic Load Rating (lbs)		Weight (lbs)
	d	de			Dynamic Cr	Static Cor	
51100	10	11	24	9	2250	3150	0.046
51101	12	13	25	9	2320	3450	0.051
51102	15	16	28	9	2370	3750	0.053
51103	17	18	30	9	2430	4100	0.057
51104	20	21	35	10	3200	5550	0.088
51105	25	26	42	11	4400	8350	0.132
51106	30	32	47	11	4600	9500	0.152
51107	35	37	52	12	4600	10000	0.187
51108	40	42	60	13	6050	1410	0.276
51109	45	47	65	14	6250	15500	0.326
51110	50	52	70	14	6450	17000	0.355
51111	55	57	78	16	7800	20900	0.498
51112	60	62	85	17	9300	20900	0.653
51113	65	67	90	18	9400	26400	0.745
51114	70	72	95	18	9700	28500	0.785
51115	75	77	100	19	10000	30500	0.880

### 51200

51200	10	12	26	11	2850	3850	0.066
51201	12	14	28	11	2960	4250	0.075
51202	15	17	32	12	3750	5600	0.101
51203	17	19	35	12	3850	6150	0.119
51204	20	22	40	14	5000	8500	0.179
51205	25	27	47	15	6250	11300	0.245
51206	30	32	52	16	6600	13100	0.306
51207	35	37	62	18	8800	17600	0.474
51208	40	42	68	19	10000	22100	0.608
51209	45	47	73	20	10700	23600	0.699
51210	50	52	78	22	10900	25100	0.833
51211	55	57	90	25	15600	35500	1.340
51212	60	62	95	26	16500	40000	1.490
51213	65	67	100	27	16800	42500	1.690
51214	70	72	105	27	17100	44500	1.750
51215	75	77	110	27	17400	47000	1.930

### 51300

51305	25	27	52	18	8050	13800	0.338
51306	30	32	60	21	9600	17700	0.593
51307	35	37	68	24	12500	23500	0.845
51308	40	42	78	26	15600	30000	1.210
51309	45	47	85	28	18000	36500	1.510



# Radial Ball Bearings

## Inch Series

### 7500 DLG

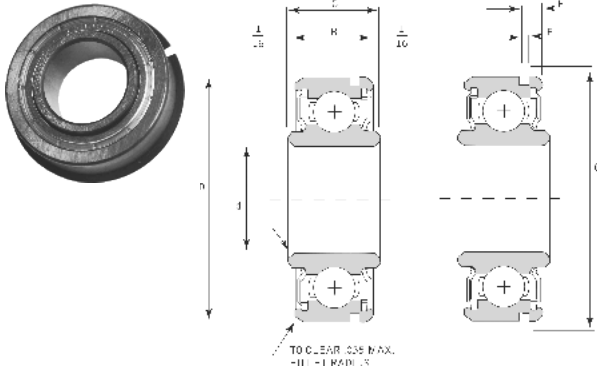

### 7600 DLG

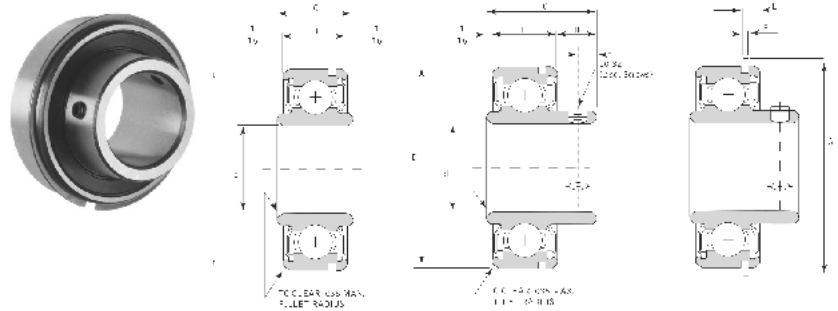

### 7500 DLG

Unit No.	Bore	Outer Diameter	Outer Width	Inner Width	(inch)	(inch)	(inch)	Basic Load Rating (lbs)		Weight (lbs)
	(inch / mm)	(inch / mm)	(inch / mm)	(inch / mm)				Dynamic Cr	Static Cor	
	d	D	B	C	E	F	G			
7508 DLG	0.5000 <b>12.70</b>	1.7500 <b>44.4500</b>	0.6250 <b>15.8750</b>	0.7500 <b>19.0500</b>	0.136	0.042	1.921	1125	657	0.30
7510 DLG	0.6250 <b>15.88</b>	1.7500 <b>44.4500</b>	0.6250 <b>15.8750</b>	0.7500 <b>19.0500</b>	0.136	0.042	1.921	1125	657	0.28
7512 DLG	0.7500 <b>19.05</b>	1.7500 <b>44.4500</b>	0.6250 <b>15.8750</b>	0.7500 <b>19.0500</b>	0.136	0.042	1.921	1125	657	0.25
7514 DLG	0.8750 <b>22.23</b>	2.0000 <b>50.8000</b>	0.6250 <b>15.8750</b>	0.7500 <b>19.0500</b>	0.136	0.042	2.156	1680	1020	0.32
7516 DLG	1.0000 <b>25.40</b>	2.0000 <b>50.8000</b>	0.6250 <b>15.8750</b>	0.7500 <b>19.0500</b>	0.136	0.042	2.156	1680	1020	0.29
7518 DLG	1.1250 <b>28.57</b>	2.5625 <b>65.0875</b>	0.7500 <b>19.0500</b>	0.8750 <b>22.2250</b>	0.190	0.065	2.843	2526	1708	0.65
7520 DLG	1.2500 <b>31.75</b>	2.5625 <b>65.0875</b>	0.7500 <b>19.0500</b>	0.8750 <b>22.2250</b>	0.190	0.065	2.843	2526	1708	0.60

### 7600 DLG

Unit No.	Bore	Outer Diameter	Outer Width	Inner Width	(inch)	(inch)	(inch)	Basic Load Rating (lbs)		Weight (lbs)
	(inch / mm)	(inch / mm)	(inch / mm)	(inch / mm)				Dynamic Cr	Static Cor	
	d	D	B	C	E	F	G			
7612 DLG	0.75 <b>19.05</b>	1.7500 <b>44.4500</b>	0.6250 <b>15.8750</b>	1.0920 <b>27.7368</b>	0.136	0.042	1.921	1125	657	0.31
7614 DLG	0.875 <b>22.23</b>	2.0000 <b>50.8000</b>	0.6250 <b>15.8750</b>	1.1790 <b>29.9466</b>	0.136	0.042	2.156	1680	1020	0.43
7616 DLG	1 <b>25.40</b>	2.0000 <b>50.8000</b>	0.6250 <b>15.8750</b>	1.1790 <b>29.9466</b>	0.136	0.042	2.156	1680	1020	0.36
7618 DLG	1.125 <b>28.57</b>	2.5625 <b>65.0875</b>	0.7500 <b>19.0500</b>	1.4170 <b>35.9918</b>	0.190	0.065	2.843	2526	1708	0.76
7620 DLG	1.25 <b>31.75</b>	2.5625 <b>65.0875</b>	0.7500 <b>19.0500</b>	1.4170 <b>35.9918</b>	0.190	0.065	2.843	2526	1708	0.82

# Tapered Roller Bearings

## Metric Series

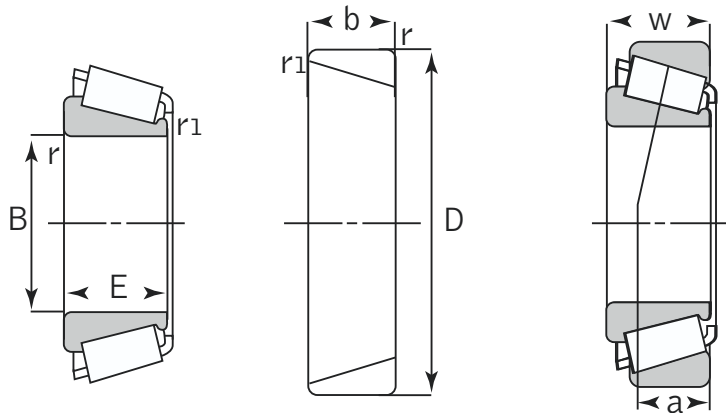

### 30200

Ass'y No.	Cone Bore (mm)	Cup O.D. (mm)	Bearing W. (mm)	Cone W. (mm)	Cup W. (mm)	Max. Shaft fillet Rad. (mm)	Max. Hang. Fillet Rad. (mm)	Weight (lbs)
	B	D	W	E	b	R	r1	
30203	17	40	13.25	12	11	1.0	1.0	0.18
30204	20	47	15.25	14	12	1.0	1	0.29
30205	25	52	16.25	15	13	1.0	1	0.33
30206	30	62	17.25	16	14	1.0	1	0.51
30207	35	72	18.25	17	15	1.5	1.5	0.73
30208	40	80	19.75	18	16	1.5	1.5	0.95
30209	45	85	20.75	19	16	1.5	1.5	1.08
30210	50	90	21.75	20	17	1.5	1.5	1.21
30211	55	100	22.75	21	18	2	1.5	1.58
30212	60	110	23.75	22	19	2	1.5	1.96
30213	65	120	24.75	23	20	2	1.5	2.53
30214	70	125	26.25	24	21	2	1.5	2.77
30215	75	130	27.25	25	22	2	1.5	2.97
30216	80	140	28.25	26	22	2.5	2	3.59
30217	85	150	30.5	28	24	2.5	2	4.62
30218	90	160	32.5	30	26	2.5	2	5.63
30219	95	170	34.5	32	27	3	2.5	6.71
30220	100	180	37	34	29	3	2.5	8.49
30221	105	190	39	36	30	3	2.5	9.90
30222	110	200	41	38	32	3	2.5	11.42
30228	140	250	45.75	42	36	4.1	3	19.84



# Tapered Roller Bearings

## Metric Series

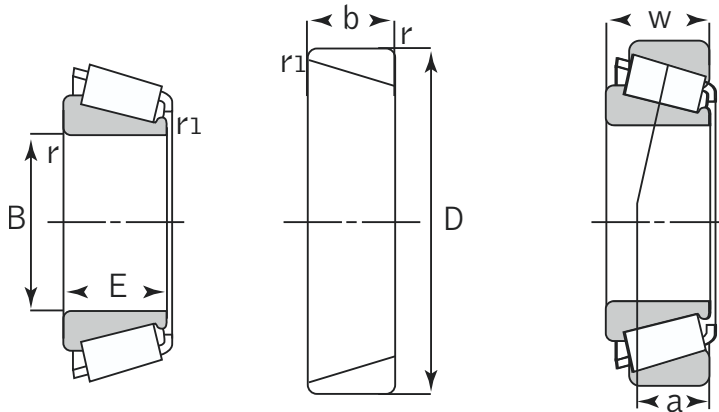

### 30300

Ass'y No.	Cone Bore (mm)	Cup O.D. (mm)	Bearing W. (mm)	Cone W. (mm)	Cup W. (mm)	Max. Shaft fillet Rad. (mm)	Max. Hang. Fillet Rad. (mm)	Weight (lbs)
	B	D	W	E	b	R	r1	
30304	20	52	16.25	15	13	1.5	1.5	0.33
30305	25	62	18.25	17	15	1.5	1.5	0.51
30306	30	72	20.75	19	16	1.5	1.5	0.73
30307	35	80	22.75	21	18	2	1.5	0.95
30308	40	90	25.25	23	20	2	1.5	1.08
30309	45	100	27.25	25	22	2	1.5	1.21
30310	50	110	29.25	27	23	2	2	1.58
30311	55	120	31.5	29	25	2.5	2	1.96
30312	60	130	33.5	31	26	3	2.5	2.53
30313	65	140	36	33	28	3	2.5	2.77
30314	70	150	38	35	30	3	2.5	2.97
30315	75	160	40	37	31	3	2.5	3.59
30316	80	170	42.5	39	33	3	2.5	4.62

### 31300

Ass'y No.	Cone Bore (mm)	Cup O.D. (mm)	Bearing W. (mm)	Cone W. (mm)	Cup W. (mm)	Max. Shaft fillet Rad. (mm)	Max. Hang. Fillet Rad. (mm)	Weight (lbs)
	B	D	W	E	b	R	r1	
31307	35	80	22.75	21	15	2	1.5	1.18
31308	40	90	25.25	23	17	2	1.5	1.61
31309	45	100	27.25	25	18	2	1.5	2.25
31310	50	110	29.25	27	19	2.5	2	2.84
31311	55	120	31.5	29	21	2.5	2	3.61
31312	60	130	33.5	31	22	3	2.5	4.47
31313	65	140	36	33	23	3	2.5	5.39
31314	70	150	28	28	25	3	2.5	6.42



# Tapered Roller Bearings

## Metric Series

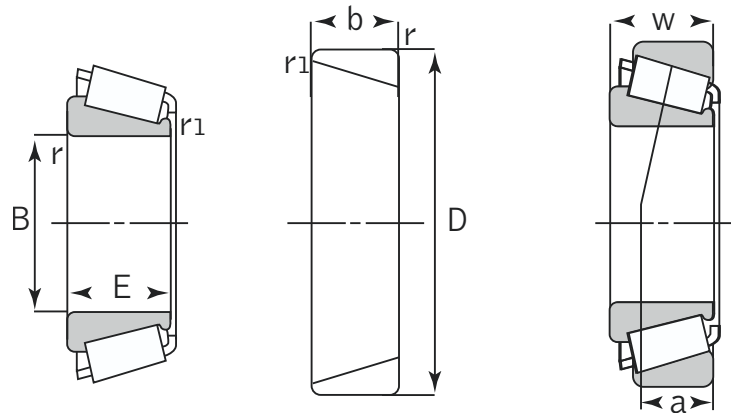

### 32000

Ass'y No.	Cone Bore	Cup O.D.	Bearing W.	Cone W.	Cup W.	Max. Shaft fillet Rad.	Max. Hang. Fillet Rad.	Weight (lbs)
	(mm)	(mm)	(mm)	(mm)	(mm)	(mm)	(mm)	
	B	D	W	E	b	R	r1	
32006	30	55	17	17	13	1	1	0.37
32007	35	62	18	18	14	1	1	0.51
32008	40	68	19	19	14.5	1	1	0.59
32009	45	75	20	20	15.5	1	1	0.77
32010	50	80	20	20	15.5	1	1	0.81
32011	55	90	23	23	17.5	1.5	1.5	1.25
32012	60	95	23	23	17.5	1.5	1.5	1.32
32013	65	100	23	23	17.5	1.5	1.5	1.41
32014	70	110	25	25	19	1.5	1.5	1.91
32015	75	115	25	25	19	1.5	1.5	2.02
32016	80	125	29	29	22	1.5	1.5	2.82
32017	85	130	29	29	22	1.5	1.5	2.97
32018	90	140	32	32	24	2	1.5	3.81
32019	95	145	32	32	24	2	1.5	3.96
32020	100	150	32	32	24	2	1.5	4.18
32021	105	160	35	35	26	2.5	2	5.28
32022	110	170	38	38	29	2.5	2	6.80
32024	120	180	38	38	29	2.5	2	7.30
32026	130	200	45	45	34	2.5	2	11.13
32028	140	210	45	45	34	2.5	2	11.68
32030	150	225	48	48	36	3	2.5	13.82
32040	200	310	70	70	53	3	2.5	42.90
32044	220	340	76	76	57	4	3	56.10
32048	240	360	76	76	76	4	3	56.54
32064	320	480	100	100	74	5	4	138.60



# Tapered Roller Bearings

## Metric Series

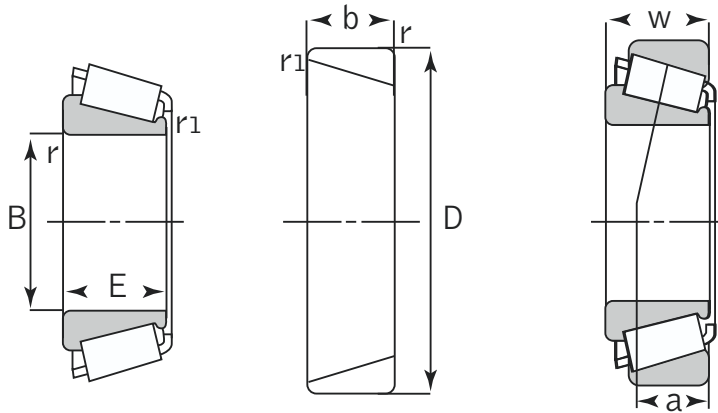

### 32200

Ass'y No.	Cone Bore (mm)	Cup O.D. (mm)	Bearing W. (mm)	Cone W. (mm)	Cup W. (mm)	Max. Shaft fillet Rad. (mm)	Max. Hang. Fillet Rad. (mm)	Weight (lbs)
	B	D	W	E	b	R	r1	
32206	30	62	21.25	20	17	1	1	0.64
32207	35	72	24.2	23	19	1.5	1.5	0.97
32208	40	80	24.750	23	19	1.5	1.5	1.19
32209	45	85	24.75	23	19	1.5	1.5	1.30
32210	50	90	24.75	23	19	1.5	1.5	1.32
32211	55	100	26.75	25	21	2	1.5	1.87
32212	60	110	29.75	28	24	2	1.5	2.53
32213	65	120	32.75	31	27	2	1.5	3.39
32214	70	125	33.25	31	27	2	1.5	3.61
32215	75	130	33.25	31	27	2	1.5	3.76
32216	80	140	35.25	33	28	2.5	2	4.51
32217	85	150	38.5	36	30	2.5	2	5.81
32218	90	160	42.5	40	34	2.5	2	7.35
32219	95	170	45.5	43	37	3	2.5	9.02
32220	100	180	49	46	39	3	2.5	10.93
32221	105	190	53	50	43	3	2.5	13.31
32222	110	200	56	53	46	3	2.5	15.80
32224	120	215	61.5	58	50	3	2.5	19.87
32226	130	230	67.75	64	54	4.1	3	24.27

# Tapered Roller Bearings

## Metric Series

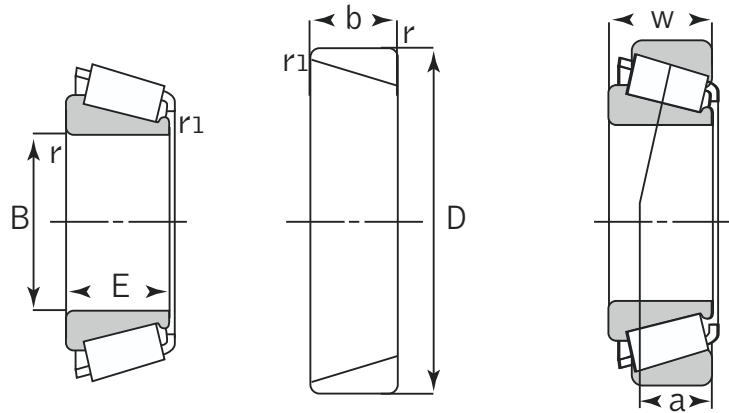

### 32300

Ass'y No.	Cone Bore	Cup O.D.	Bearing W.	Cone W.	Cup W.	Max. Shaft fillet Rad.	Max. Hang. Fillet Rad.	Weight (lbs)
	(mm)	(mm)	(mm)	(mm)	(mm)	(mm)	(mm)	
	B	D	W	E	b	R	r1	
32306	30	72	28.75	27	23	1.5	1.5	1.23
32307	35	80	32.75	31	25	2	1.5	1.67
32308	40	90	35.25	33	27	2	1.5	2.27
32309	45	100	38.25	36	30	2	1.5	3.01
32310	50	110	42.25	40	33	2.5	2	4.05
32311	55	120	45.5	43	35	2.5	2	5.15
32312	60	130	48.5	46	37	3	2.5	6.38
32313	65	140	51	48	39	3	2.5	7.79
32314	70	150	54	51	42	3	2.5	9.44
32316	80	170	61.5	58	48	3	2.5	13.90
32317	85	180	63.5	60	49	4	3	15.99

### 33100

Ass'y No.	Cone Bore	Cup O.D.	Bearing W.	Cone W.	Cup W.	Max. Shaft fillet Rad.	Max. Hang. Fillet Rad.	Weight (lbs)
	(mm)	(mm)	(mm)	(mm)	(mm)	(mm)	(mm)	
	B	D	W	E	b	R	r1	
33110	50	85	26	26	20	1.5	1.5	1.30
33111	55	95	30	30	23	1.5	1.5	1.87
33112	60	100	30	30	23	1.5	1.5	2.00
33113	65	110	34	34	26.5	1.5	1.5	2.75
33114	70	120	37	37	29	2	1.5	3.70
33115	75	125	37	37	29	2	1.5	3.89
33116	80	130	37	37	29	2	1.5	4.14
33117	85	140	41	41	32	2.5	2	5.46
33118	90	150	45	45	35	2.5	2	6.97



# Tapered Roller Bearings

## Inch Series

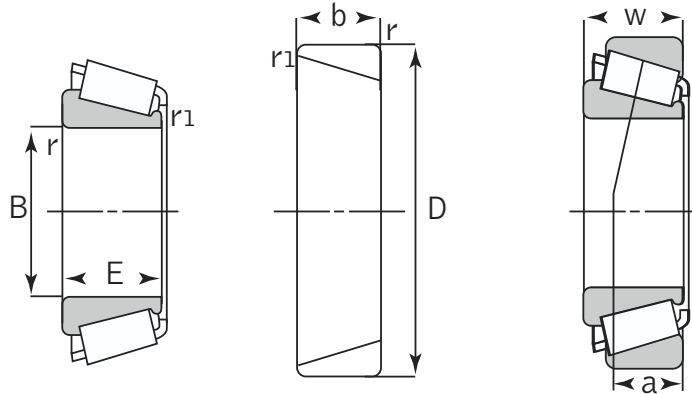

### Cups & Cones

Bearing No.		Assembly No.		Dimensions (inches / mm)							Load Center	Mass kg / lbs
Cone	Cup			B	D	W	E	b	R min r	min	a (mm)	
02872	02820	*	SET 50	1.125 <b>28.575</b>	2.875 <b>73.025</b>	0.875 <b>22.225</b>	0.875 <b>22.225</b>	0.687 <b>17.462</b>	0.03 <b>0.8</b>	0.13 <b>3.3</b>		0.480 <b>1.056</b>
07093	07196	*	*	0.937 <b>23.812</b>	1.969 <b>50.01</b>	0.531 <b>13.495</b>	0.561 <b>14.26</b>	0.375 <b>9.525</b>	0.04 <b>1</b>	0.04 <b>1</b>		0.123 <b>0.271</b>
07100	07196	A 19	*	1.000 <b>25.4</b>	1.969 <b>50.01</b>	0.531 <b>13.495</b>	0.561 <b>14.25</b>	0.375 <b>9.525</b>	0.04 <b>1</b>	0.04 <b>1</b>	3	0.115 <b>0.253</b>
07100	07196	*	*	1.000 <b>25.4</b>	1.969 <b>50.01</b>	0.531 <b>13.495</b>	0.561 <b>14.26</b>	0.375 <b>9.525</b>	0.04 <b>1</b>	0.04 <b>1</b>		0.117 <b>0.257</b>
09067	09195	*	*	0.750 <b>19.05</b>	1.938 <b>49.225</b>	0.710 <b>18.034</b>	0.750 <b>19.05</b>	0.563 <b>14.288</b>	0.05 <b>1.3</b>	0.05 <b>1.3</b>		0.179 <b>0.394</b>
11590	11520	*	SET 61	0.625 <b>15.875</b>	1.687 <b>42.862</b>	0.563 <b>14.288</b>	0.563 <b>14.288</b>	0.375 <b>9.525</b>	0.06 <b>1.5</b>	0.06 <b>1.5</b>		0.100 <b>0.220</b>
11590	11520	*	*	0.625 <b>15.875</b>	1.687 <b>42.862</b>	0.563 <b>14.288</b>	0.563 <b>14.288</b>	0.375 <b>9.525</b>	0.06 <b>1.5</b>	0.06 <b>1.5</b>		0.103 <b>0.227</b>
14125 A	14276	*	*	1.250 <b>31.75</b>	2.717 <b>69.012</b>	0.781 <b>19.845</b>	0.771 <b>19.583</b>	0.625 <b>15.875</b>	0.14 <b>3.5</b>	0.05 <b>1.3</b>		0.360 <b>0.792</b>
15101	15245	*	SET 73	1.000 <b>25.4</b>	2.441 <b>62</b>	0.750 <b>19.05</b>	0.813 <b>20.638</b>	0.563 <b>14.288</b>	0.14 <b>3.5</b>	0.05 <b>1.3</b>		0.300 <b>0.660</b>
15103 S	15243	*	*	1.030 <b>26.162</b>	2.437 <b>61.912</b>	0.750 <b>19.05</b>	0.785 <b>19.939</b>	0.563 <b>14.288</b>	0.03 <b>0.8</b>	0.08 <b>2</b>		0.280 <b>0.616</b>
15106	15245	*	SET 51	1.063 <b>26.988</b>	2.441 <b>62</b>	0.750 <b>19.05</b>	0.813 <b>20.638</b>	0.563 <b>14.288</b>	0.05 <b>1.3</b>	0.03 <b>0.8</b>		0.291 <b>0.640</b>
15123	15245	*	*	1.250 <b>31.75</b>	2.441 <b>62</b>	0.715 <b>18.161</b>	0.750 <b>19.05</b>	0.563 <b>14.288</b>	0.05 <b>1.3</b>	0.05 <b>1.3</b>		0.244 <b>0.537</b>
17887	17831	*	SET 62	1.781 <b>45.23</b>	3.149 <b>79.985</b>	0.781 <b>19.842</b>	0.813 <b>20.638</b>	0.594 <b>15.08</b>	0.08 <b>2</b>	0.05 <b>1.3</b>		0.400 <b>0.880</b>
17887	17831	*	*	1.781 <b>45.23</b>	3.149 <b>79.985</b>	0.781 <b>19.842</b>	0.813 <b>20.638</b>	0.594 <b>15.08</b>	0.08 <b>2</b>	0.05 <b>1.3</b>		0.252 <b>0.554</b>
18590	18520	*	*	1.625 <b>41.275</b>	2.875 <b>73.025</b>	0.656 <b>16.667</b>	0.687 <b>17.462</b>	0.500 <b>12.7</b>	0.14 <b>3.5</b>	0.06 <b>1.5</b>		0.281 <b>0.618</b>
18790	18720	*	*	2.000 <b>50.8</b>	3.346 <b>85</b>	0.687 <b>17.462</b>	0.687 <b>17.462</b>	0.531 <b>13.495</b>	0.14 <b>3.5</b>	0.06 <b>1.5</b>		0.374 <b>0.823</b>
1988	1922	A 21	SET 21	1.125 <b>28.575</b>	2.250 <b>57.15</b>	0.781 <b>19.845</b>	0.762 <b>19.355</b>	0.625 <b>15.875</b>	0.14 <b>3.5</b>	0.06 <b>1.5</b>	5.9	0.213 <b>0.469</b>
24780	24720	*	*	1.625 <b>41.275</b>	3.000 <b>76.2</b>	0.875 <b>22.225</b>	0.906 <b>23.02</b>	0.687 <b>17.462</b>	0.14 <b>3.5</b>	0.03 <b>0.8</b>		0.432 <b>0.950</b>
25580	25520	*	SET 52	1.750 <b>44.45</b>	3.265 <b>82.931</b>	0.937 <b>23.812</b>	1.000 <b>25.4</b>	0.750 <b>19.05</b>	0.14 <b>3.5</b>	0.03 <b>0.8</b>		0.561 <b>1.234</b>
25580	25523	*	SET 53	1.750 <b>44.45</b>	3.265 <b>82.931</b>	1.063 <b>26.988</b>	1.000 <b>25.4</b>	0.875 <b>22.225</b>	0.14 <b>3.5</b>	0.09 <b>2.3</b>		0.603 <b>1.327</b>
25580	25520	*	*	1.750 <b>44.45</b>	3.265 <b>82.931</b>	0.937 <b>23.812</b>	1.000 <b>25.4</b>	0.750 <b>19.05</b>	0.14 <b>3.5</b>	0.03 <b>0.8</b>		0.561 <b>1.234</b>

# Tapered Roller Bearings

## Inch Series

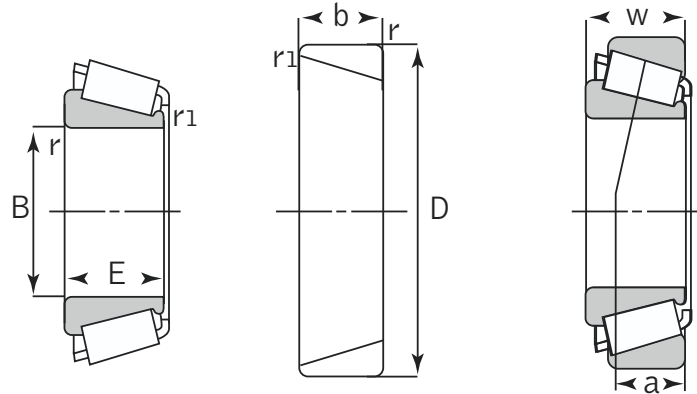

### Cups & Cones

Bearing No.		Assembly No.		Dimensions (inches / mm)								Load Center	Mass kg / lbs
Cone	Cup			B	D	W	E	b	R min r	min	a (mm)		
25590	25523	*	SET 55	1.796 <b>45.618</b>	3.265 <b>82.931</b>	1.063 <b>26.988</b>	1.000 <b>25</b>	0.875 <b>22.225</b>	0.14 <b>3.5</b>	0.09 <b>2.3</b>		0.588 <b>1.294</b>	
25590	25520	*	*	1.796 <b>45.618</b>	3.265 <b>82.931</b>	0.937 <b>23.812</b>	1.000 <b>25.400</b>	0.750 <b>19.05</b>	0.14 <b>3.5</b>	0.03 <b>0.8</b>		0.544 <b>1.197</b>	
25590	25523	*	*	1.796 <b>45.618</b>	3.265 <b>82.931</b>	1.063 <b>26.988</b>	1.000 <b>25.400</b>	0.875 <b>22.225</b>	0.14 <b>3.5</b>	0.09 <b>2.3</b>		0.603 <b>1.327</b>	
25877	25821	*	*	1.375 <b>34.925</b>	2.875 <b>73.025</b>	0.937 <b>23.812</b>	0.969 <b>24.608</b>	0.750 <b>19.05</b>	0.06 <b>1.5</b>	0.03 <b>0.8</b>		0.471 <b>1.036</b>	
25880	25820	*	SET 85	1.436 <b>36.487</b>	2.875 <b>73.025</b>	0.937 <b>23.812</b>	0.969 <b>24.608</b>	0.750 <b>19.05</b>	0.06 <b>1.5</b>	0.09 <b>2.3</b>		0.559 <b>1.230</b>	
26882	26822	*	*	1.625 <b>41.275</b>	3.125 <b>79.375</b>	0.937 <b>23.812</b>	1.000 <b>25.400</b>	0.750 <b>19.05</b>	0.14 <b>3.5</b>	0.03 <b>0.8</b>		0.530 <b>1.166</b>	
27687	27620	*	*	3.250 <b>82.55</b>	4.937 <b>125.412</b>	1.000 <b>25.4</b>	1.000 <b>25.4</b>	0.781 <b>19.845</b>	0.14 <b>3.5</b>	0.06 <b>1.5</b>		1.070 <b>2.354</b>	
2788	2720	*	*	1.500 <b>38.1</b>	3.000 <b>76.2</b>	0.937 <b>23.812</b>	1.010 <b>25.654</b>	0.750 <b>19.05</b>	0.14 <b>3.5</b>	0.13 <b>3.3</b>		0.402 <b>0.884</b>	
28584	28521	*	*	2.063 <b>52.388</b>	3.625 <b>92.075</b>	0.969 <b>24.608</b>	1.000 <b>25.4</b>	0.781 <b>19.845</b>	0.14 <b>3.5</b>	0.03 <b>0.8</b>		0.677 <b>1.489</b>	
28985	28920	*	*	2.375 <b>60.325</b>	4.000 <b>101.6</b>	1.000 <b>25.4</b>	1.000 <b>25.4</b>	0.781 <b>19.845</b>	0.14 <b>3.5</b>	0.13 <b>3.3</b>		0.811 <b>1.784</b>	
29590	29520	*	*	2.625 <b>66.675</b>	4.250 <b>107.95</b>	1.000 <b>25.4</b>	1.000 <b>25.4</b>	0.750 <b>19.05</b>	0.14 <b>3.5</b>	0.13 <b>3.3</b>		0.860 <b>1.892</b>	
31594	31520	*	SET 57	1.375 <b>34.92</b>	3.000 <b>76.2</b>	1.156 <b>29.37</b>	1.125 <b>28.575</b>	0.937 <b>23.812</b>	0.13 <b>3.3</b>	0.06 <b>1.5</b>		0.627 <b>1.379</b>	
33275	33462	*	*	2.750 <b>69.85</b>	4.625 <b>117.475</b>	1.187 <b>30.162</b>	1.187 <b>30.162</b>	0.937 <b>23.812</b>	0.14 <b>3.5</b>	0.13 <b>3.3</b>		1.280 <b>2.816</b>	
3379	3320	*	*	1.375 <b>34.925</b>	3.156 <b>80.167</b>	1.156 <b>29.37</b>	1.196 <b>30.391</b>	0.937 <b>23.812</b>	0.14 <b>3.5</b>	0.13 <b>3.3</b>		0.732 <b>1.610</b>	
368 A	362 A	*	*	2.000 <b>50.8</b>	3.500 <b>88.9</b>	0.813 <b>20.638</b>	0.875 <b>22.225</b>	0.650 <b>16.513</b>	0.14 <b>3.5</b>	0.05 <b>1.3</b>		0.516 <b>1.135</b>	
368 S	362	*	SET 66	2.031 <b>51.592</b>	3.543 <b>90</b>	0.813 <b>20.638</b>	0.875 <b>22.225</b>	0.650 <b>16.513</b>	0.08 <b>2.0</b>	0.08 <b>2.0</b>		0.507 <b>1.115</b>	
3780	3720	*	*	2.000 <b>50.8</b>	3.672 <b>93.264</b>	1.187 <b>30.162</b>	1.193 <b>30.302</b>	0.937 <b>23.812</b>	0.14 <b>3.5</b>	0.13 <b>3.3</b>		0.848 <b>1.866</b>	
3782	3720	*	SET 406	1.750 <b>44.45</b>	3.672 <b>93.264</b>	1.187 <b>30.162</b>	1.193 <b>30.302</b>	0.937 <b>23.812</b>	0.14 <b>3.5</b>	0.13 <b>3.3</b>		0.961 <b>2.114</b>	
387 A	382 A	*	SET 74	2.250 <b>57.15</b>	3.813 <b>96.838</b>	0.827 <b>21</b>	0.864 <b>21.946</b>	0.625 <b>15.875</b>	0.14 <b>3.5</b>	0.03 <b>0.8</b>		0.581 <b>1.278</b>	
387 A	382 S	*	SET 75	2.250 <b>57.15</b>	3.813 <b>96.838</b>	1.000 <b>25.4</b>	0.864 <b>21.946</b>	0.798 <b>20.274</b>	0.14 <b>3.5</b>	0.09 <b>2.3</b>		0.650 <b>1.430</b>	



# Tapered Roller Bearings

Inch Series

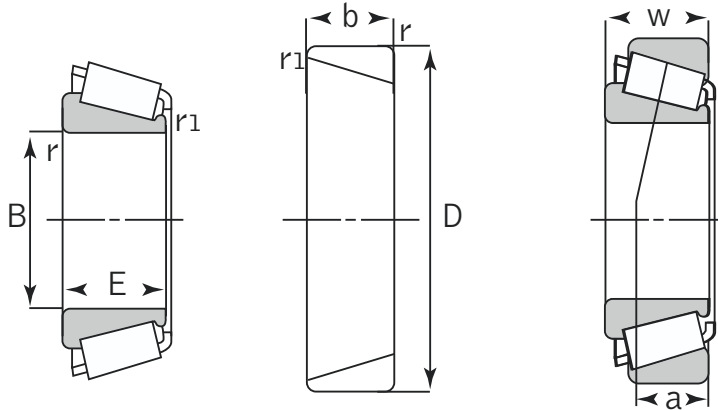

## Cups & Cones

Bearing No.		Assembly No.		Dimensions (inches / mm)							Load Center a (mm)	Mass kg / lbs
Cone	Cup			B	D	W	E	b	R min r	min		
387 AS	382 A	*	SET76	2.250 <b>57.150</b>	3.813 <b>96.838</b>	0.827 <b>21</b>	0.864 <b>21.946</b>	0.625 <b>15.875</b>	0.20 <b>5</b>	0.03 <b>0.8</b>		0.576 <b>1.267</b>
387 AS	382 S	*	*	2.250 <b>57.150</b>	3.813 <b>96.838</b>	0.827 <b>21</b>	0.864 <b>21.946</b>	0.625 <b>15.875</b>	0.20 <b>5.0</b>	0.03 <b>0.8</b>		0.576 <b>1.267</b>
388 A	382	*	SET 77	2.265 <b>57.531</b>	3.875 <b>98.425</b>	0.827 <b>21</b>	0.864 <b>21.946</b>	0.702 <b>17.826</b>	0.14 <b>3.5</b>	0.03 <b>0.8</b>		0.610 <b>1.342</b>
395	394 A	*	*	2.500 <b>63.5</b>	4.331 <b>110</b>	0.866 <b>22</b>	0.866 <b>21.996</b>	0.741 <b>18.824</b>	0.14 <b>3.5</b>	0.05 <b>1.3</b>		0.847 <b>1.863</b>
39581	39520	*	*	2.250 <b>57.15</b>	4.437 <b>112.712</b>	1.187 <b>30.162</b>	1.187 <b>30.162</b>	0.937 <b>23.812</b>	0.31 <b>8.0</b>	0.13 <b>3.3</b>		1.380 <b>3.036</b>
39590	39520	*	*	2.625 <b>66.675</b>	4.437 <b>112.712</b>	1.187 <b>30.162</b>	1.187 <b>30.162</b>	0.937 <b>23.812</b>	0.14 <b>3.5</b>	0.13 <b>3.3</b>		1.190 <b>2.618</b>
3982	3920	*	*	2.500 <b>63</b>	4.437 <b>112.712</b>	1.187 <b>30.162</b>	1.183 <b>30.048</b>	0.937 <b>23.812</b>	0.14 <b>3.5</b>	0.13 <b>3.3</b>		1.200 <b>2.640</b>
3984	3920	*	*	2.625 <b>66.675</b>	4.437 <b>112.712</b>	1.187 <b>30.162</b>	1.183 <b>30.048</b>	0.937 <b>23.812</b>	0.14 <b>3.5</b>	0.13 <b>3.3</b>		1.180 <b>2.596</b>
418	414	*	*	1.500 <b>38.1</b>	3.484 <b>88.5</b>	1.063 <b>26.988</b>	1.145 <b>29.083</b>	0.875 <b>22.225</b>	0.14 <b>3.5</b>	0.06 <b>1.5</b>		0.841 <b>1.850</b>
42687	42620	*	*	3.000 <b>76.2</b>	5.000 <b>127</b>	1.187 <b>30.162</b>	1.220 <b>31</b>	0.875 <b>22.225</b>	0.14 <b>3.5</b>	0.13 <b>3.3</b>		1.460 <b>3.212</b>
4388	4335	*	*	1.625 <b>41.275</b>	3.561 <b>90.448</b>	1.563 <b>39.688</b>	1.590 <b>40.386</b>	1.313 <b>33.338</b>	0.14 <b>3.5</b>	0.13 <b>3.3</b>		1.220 <b>2.684</b>
47686	47620	*	SET 411	3.250 <b>82.55</b>	5.250 <b>133.35</b>	1.313 <b>33.338</b>	1.313 <b>33.338</b>	1.031 <b>26.195</b>	0.14 <b>3.5</b>	0.13 <b>3.3</b>		1.720 <b>3.784</b>
497	493	*	SET 68	3.375 <b>85.725</b>	5.375 <b>136.525</b>	1.187 <b>30.162</b>	1.133 <b>28.789</b>	0.875 <b>22.225</b>	0.14 <b>3.5</b>	0.13 <b>3.3</b>		1.550 <b>3.410</b>
56425	56650	*	SET 79	4.250 <b>107.95</b>	6.500 <b>165.1</b>	1.437 <b>36.512</b>	1.437 <b>36.512</b>	1.063 <b>26.988</b>	0.14 <b>3.5</b>	0.13 <b>3.3</b>		2.690 <b>5.918</b>
57410 S	LM 29710 S	A7	SET 42	1.500 <b>38.1</b>	2.563 <b>65.088</b>	0.710 <b>18.034</b>	0.832 <b>21.139</b>	0.550 <b>13.97</b>	0.14 <b>3.5</b>	0.05 <b>1.3</b>	4.3	0.240 <b>0.528</b>
580	572	*	SET 401	3.250 <b>82.55</b>	5.511 <b>139.992</b>	1.437 <b>36.512</b>	1.421 <b>36.098</b>	1.125 <b>28.575</b>	0.14 <b>3.5</b>	0.13 <b>3.3</b>		2.220 <b>4.884</b>
594 A	592 A	*	SET 403	3.632 <b>92.25</b>	6.000 <b>152.4</b>	1.563 <b>39.688</b>	1.430 <b>36.322</b>	1.187 <b>30.162</b>	0.20 <b>5.0</b>	0.13 <b>3.3</b>		2.510 <b>5.522</b>
598 A	592 A	*	SET 404	3.625 <b>92.075</b>	6.000 <b>152.4</b>	1.563 <b>39.688</b>	1.430 <b>36.322</b>	1.187 <b>30.162</b>	0.25 <b>6.4</b>	0.13 <b>3.3</b>		2.630 <b>5.786</b>

# Tapered Roller Bearings

## Inch Series

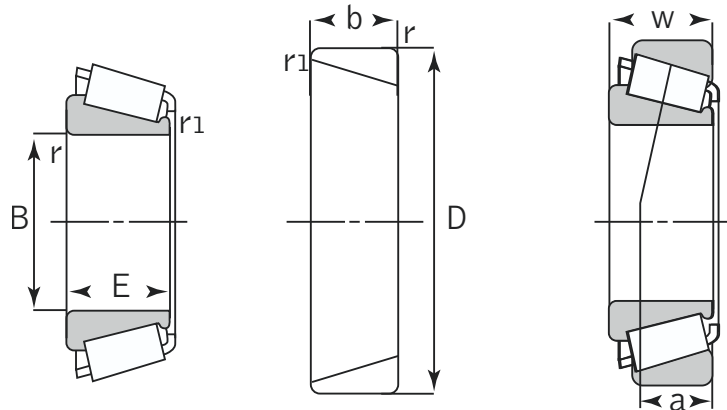

## Cups & Cones

Bearing No.		Assembly No.		Dimensions (inches / mm)							Load Center	Mass kg / lbs
Cone	Cup			B	D	W	E	b	R min r	min	a (mm)	
A 6075	A 6175	*	*	0.750 <b>19.05</b>	1.574 <b>39.992</b>	0.473 <b>12.014</b>	0.439 <b>11.153</b>	0.375 <b>9.525</b>	0.04 <b>1</b>	0.05 <b>1.3</b>		0.065 <b>0.143</b>
HM 212047	HM 212011	*	SET 412	2.500 <b>63.5</b>	4.813 <b>122.238</b>	1.500 <b>38.1</b>	1.510 <b>38.354</b>	1.170 <b>29.718</b>	0.28 <b>7</b>	0.13 <b>3.3</b>		1.940 <b>4.268</b>
HM 212049	HM 212011	*	SET 413	2.625 <b>66.675</b>	4.813 <b>122.238</b>	1.500 <b>38.1</b>	1.510 <b>38.354</b>	1.170 <b>29.718</b>	0.14 <b>3.5</b>	0.13 <b>3.3</b>		1.850 <b>4.070</b>
HM 218248	HM 218210	*	SET 414	3.542 <b>89.975</b>	5.786 <b>146.975</b>	1.575 <b>40</b>	1.575 <b>40</b>	1.280 <b>32.5</b>	0.28 <b>7</b>	0.14 <b>3.5</b>		2.520 <b>5.544</b>
HM 518445	HM 518410	*	SET 415	3.500 <b>88.9</b>	6.000 <b>152.4</b>	1.563 <b>39.688</b>	1.563 <b>39.688</b>	1.188 <b>30.163</b>	0.14 <b>3.5</b>	0.13 <b>3.3</b>		2.840 <b>6.248</b>
HM 803145	HM 803110	*	*	1.625 <b>41.275</b>	3.500 <b>88.9</b>	1.187 <b>30.162</b>	1.156 <b>29.37</b>	0.906 <b>23.02</b>	0.03 <b>0.8</b>	0.13 <b>3.3</b>		0.892 <b>1.962</b>
HM 803146	HM 803110	*	*	1.625 <b>41.275</b>	3.500 <b>88.9</b>	1.187 <b>30.162</b>	1.156 <b>29.37</b>	0.906 <b>23.02</b>	0.14 <b>3.5</b>	0.13 <b>3.3</b>		0.892 <b>1.962</b>
HM 803149	HM 803110	*	SET 83	1.750 <b>44.45</b>	3.500 <b>88.9</b>	1.187 <b>30.162</b>	1.156 <b>29.37</b>	0.906 <b>23.02</b>	0.14 <b>3.5</b>	0.13 <b>3.3</b>		0.849 <b>1.868</b>
HM 807040	HM 807010	*	SET 85	1.750 <b>44.45</b>	4.125 <b>104.775</b>	1.437 <b>36.512</b>	1.437 <b>36.512</b>	1.125 <b>28.575</b>	0.14 <b>3.5</b>	0.13 <b>3.3</b>		1.620 <b>3.564</b>
HM 88542	HM 88510	*	SET 81	1.250 <b>31.75</b>	2.875 <b>73.025</b>	1.156 <b>29.37</b>	1.094 <b>27.783</b>	0.906 <b>23.02</b>	0.13 <b>3.3</b>	0.05 <b>1.3</b>		0.622 <b>1.368</b>
HM 88649	HM 88610	*	SET 67	1.375 <b>34.925</b>	2.844 <b>72.233</b>	1.000 <b>25.4</b>	1.000 <b>25.4</b>	0.781 <b>19.842</b>	0.09 <b>2.3</b>	0.09 <b>2.3</b>		0.489 <b>1.076</b>
HM 88649	HM 88610	*	*	1.375 <b>34.925</b>	2.844 <b>72.233</b>	1.000 <b>25.4</b>	1.000 <b>25.4</b>	0.781 <b>19.842</b>	0.09 <b>2.3</b>	0.09 <b>2.3</b>		0.485 <b>1.067</b>
HM 903249	HM 903210	*	SET 64	1.750 <b>44.45</b>	3.750 <b>95.25</b>	1.219 <b>30.958</b>	1.125 <b>28.575</b>	0.875 <b>22.225</b>	0.14 <b>3.5</b>	0.03 <b>0.8</b>		1.000 <b>2.200</b>
JL 26749	JL 26710	*	SET 46	1.260 <b>32</b>	2.087 <b>53</b>	0.571 <b>14.5</b>	0.591 <b>15</b>	0.453 <b>11.5</b>	0.14 <b>3.5</b>	0.05 <b>1.3</b>		0.120 <b>0.264</b>
JL 68145	JL 68111 Z	A 31	SET 24	1.417 <b>36</b>	2.362 <b>60</b>	0.625 <b>15.875</b>	0.727 <b>18.46</b>	0.472 <b>11.99</b>	0.08 <b>2</b>	0.05 <b>1.3</b>	2.5 0.1	0.183 <b>0.403</b>
JL 69345	JL 69310 Z	*	*	1.496 <b>38</b>	2.480 <b>63</b>	0.669 <b>17</b>	0.748 <b>19</b>	0.531 <b>13.5</b>		0.05 <b>1.3</b>		0.198 <b>0.436</b>
JL 69349	JL 69310	A 18	SET 11	1.496 <b>38</b>	2.480 <b>63</b>	0.669 <b>17</b>	0.669 <b>17</b>	0.531 <b>13.5</b>		0.05 <b>1.3</b>	2.3 0.09	0.194 <b>0.427</b>



# Tapered Roller Bearings

## Inch Series

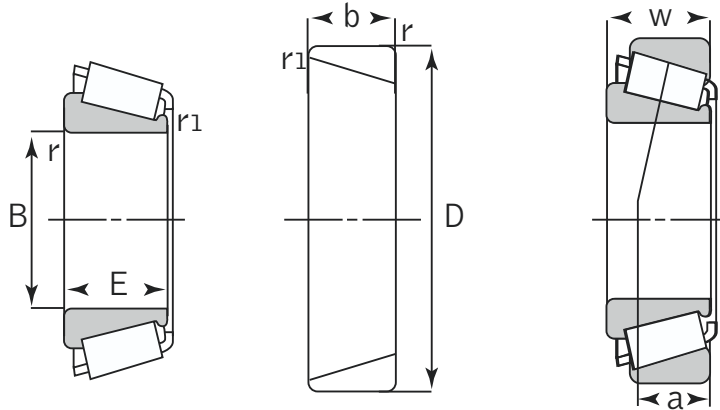

### Cups & Cones

Bearing No.		Assembly No.		Dimensions (inches / mm)							Load Center	Mass kg / lbs
Cone	Cup			B	D	W	E	b	R min r	min	a (mm)	
JLM 104948	JLM 104910	*	*	1.969 <b>50</b>	3.228 <b>82</b>	0.846 <b>21.5</b>	0.846 <b>21.5</b>	0.669 <b>17</b>	0.12 <b>3</b>	0.02 <b>0.5</b>		0.420 <b>0.924</b>
JLM 506848E	JLM 506810	A 22	SET 25	2.165 <b>55</b>	3.543 <b>90</b>	0.906 <b>23</b>	1.024 <b>26</b>	0.728 <b>18.5</b>	0.14 <b>3.5</b>	0.02 <b>0.5</b>	0.11 2.8	0.576 <b>1.267</b>
JLM 506849 A	JLM 506811	A7	SET 7	2.165 <b>55</b>	3.543 <b>90</b>	0.906 <b>23</b>	0.906 <b>23</b>	0.728 <b>18.5</b>	0.06 <b>1.5</b>	0.02 <b>0.5</b>	0.11 2.8	0.576 <b>1.267</b>
JLM 67042	LM 67010	*	SET 30	1.102 <b>28</b>	2.250 <b>57.15</b>	0.687 <b>17.462</b>	0.687 <b>17.462</b>	0.531 <b>13.495</b>	0.14 <b>3.5</b>	0.06 <b>1.5</b>		0.270 <b>0.594</b>
JM 204149	JM 205110	*	*	1.969 <b>50</b>	3.543 <b>90</b>	1.102 <b>28</b>	1.102 <b>28</b>	0.906 <b>23</b>	0.12 <b>3</b>	0.10 <b>2.5</b>		0.752 <b>1.654</b>
JM 207049	JM 207010	*	*	2.165 <b>55</b>	3.740 <b>95</b>	1.142 <b>29</b>	1.142 <b>29</b>	0.925 <b>23.5</b>	0.06 <b>1.5</b>	0.10 <b>2.5</b>		0.820 <b>1.804</b>
L 44643	L 44610	A 14	SET 14	1.000 <b>25.4</b>	1.980 <b>50.292</b>	0.560 <b>14.224</b>	0.580 <b>14.732</b>	0.420 <b>10.668</b>	0.05 <b>1.3</b>	0.05 <b>1.3</b>	0.13 3.4	0.130 <b>0.286</b>
L 44649	L 44610	A 4	SET 4	1.063 <b>26.988</b>	1.980 <b>50.292</b>	0.561 <b>14.224</b>	0.580 <b>14.732</b>	0.421 <b>10.668</b>	0.14 <b>3.5</b>	0.05 <b>1.3</b>	0.13 3.4	0.115 <b>0.253</b>
L 45499	L 45410	A 15	SET 8	1.142 <b>29</b>	1.980 <b>50.292</b>	0.560 <b>14.224</b>	0.580 <b>14.732</b>	0.420 <b>10.668</b>	0.14 <b>3.5</b>	0.05 <b>1.3</b>	0.14 3.5	0.110 <b>0.242</b>
L 68149	L 68110	A 13	SET 13	1.377 <b>34.988</b>	2.328 <b>59.131</b>	0.625 <b>15.875</b>	0.660 <b>16.764</b>	0.470 <b>11.938</b>	0.14 <b>3.5</b>	0.05 <b>1.3</b>	0.1 2.5	0.167 <b>0.367</b>
L 68149	L 68111	A 17	SET 17	1.377 <b>34.988</b>	2.361 <b>59.974</b>	0.625 <b>15.875</b>	0.660 <b>16.764</b>	0.470 <b>11.938</b>	0.14 <b>3.5</b>	0.05 <b>1.3</b>	0.1 2.5	0.174 <b>0.383</b>
LM 102949	LM 102910	*	SET 47	1.781 <b>45.242</b>	2.891 <b>73.431</b>	0.771 <b>19.588</b>	0.780 <b>19.812</b>	0.620 <b>15.748</b>	0.14 <b>3.5</b>	0.03 <b>0.8</b>	0.19 4.7	0.303 <b>0.667</b>
LM 102949	LM 102910	*	*	1.781 <b>45.242</b>	2.891 <b>73.431</b>	0.771 <b>19.588</b>	0.780 <b>19.812</b>	0.620 <b>15.748</b>	0.14 <b>3.5</b>	0.03 <b>0.8</b>		0.307 <b>0.675</b>
LM 104949E	LM 104910	A 23	SET 23	2.000 <b>50.8</b>	3.250 <b>82.55</b>	2.038 <b>51.765</b>	2.038 <b>51.765</b>	1.638 <b>41.605</b>	0.14 <b>3.5</b>	0.05 <b>1.3</b>	0.23 5.8	1.100 <b>2.420</b>
LM 104949E	LM 104911	A 38	SET 38	2.000 <b>50.8</b>	3.250 <b>82.55</b>	0.850 <b>21.59</b>	0.875 <b>22.225</b>	0.650 <b>16.51</b>	0.14 <b>3.5</b>	0.05 <b>1.3</b>	0.23 5.8	0.419 <b>0.922</b>
LM 11749	LM 11710	A 1	SET 1	0.687 <b>17.462</b>	1.570 <b>39.878</b>	0.545 <b>13.843</b>	0.575 <b>14.605</b>	0.421 <b>10.688</b>	0.05 <b>1.3</b>	0.05 <b>1.3</b>	0.2 5.3	0.083 <b>0.183</b>
LM 11949	LM 11910	A 2	SET 2	0.750 <b>19.050</b>	1.781 <b>45.237</b>	0.610 <b>15.494</b>	0.655 <b>16.637</b>	0.475 <b>12.065</b>	0.05 <b>1.3</b>	0.05 <b>1.3</b>	0.22 5.6	0.124 <b>0.273</b>
LM 12748	LM 12710	A 34	SET 34	0.844 <b>21.43</b>	1.781 <b>45.237</b>	0.610 <b>15.494</b>	0.655 <b>16.637</b>	0.475 <b>12.065</b>	0.05 <b>1.3</b>	0.05 <b>1.3</b>	0.21 5.4	0.121 <b>0.266</b>



# Tapered Roller Bearings

## Inch Series

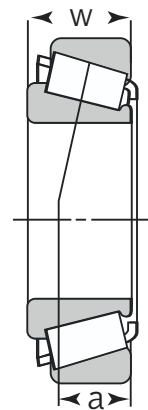
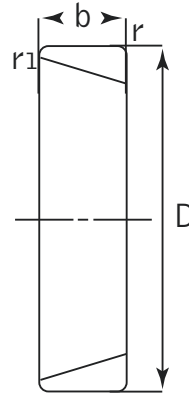
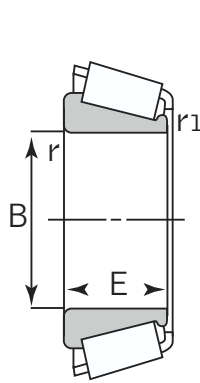

## Cups & Cones

Bearing No.		Assembly No.		Dimensions (inches / mm)							Load Center	Mass kg / lbs
Cone	Cup			B	D	W	E	b	R min r	min	a (mm)	
LM 12749	LM 12711	A 16	SET 16	0.866 <b>21.986</b>	1.810 <b>45.974</b>	0.610 <b>15.494</b>	0.655 <b>16.637</b>	0.475 <b>12.065</b>	0.05 <b>1.3</b>	0.05 <b>1.3</b>	5.4 0.21	0.121 <b>0.266</b>
LM 29748	LM 29710	A 81	SET 56	1.500 <b>38.1</b>	2.563 <b>65.088</b>	0.710 <b>18.034</b>	0.720 <b>18.288</b>	0.550 <b>13.97</b>		0.05 <b>1.3</b>	4.3 0.17	0.233 <b>0.513</b>
LM 29749	LM 29710	*	SET 70	1.500 <b>38.1</b>	2.563 <b>65.088</b>	0.710 <b>18.034</b>	0.641 <b>16.288</b>	0.550 <b>13.97</b>	0.09 <b>2.3</b>	0.05 <b>1.3</b>		0.235 <b>0.517</b>
LM 300849	LM 300811	*	*	1.614 <b>40.988</b>	2.676 <b>67.975</b>	0.689 <b>17.5</b>	0.709 <b>18.000</b>	0.531 <b>13.5</b>		0.06 <b>1.5</b>		0.234 <b>0.515</b>
LM 48548	LM 48510	A 5	SET 5	1.375 <b>34.925</b>	2.563 <b>65.088</b>	0.710 <b>18.034</b>	0.720 <b>18.288</b>	0.550 <b>13.97</b>		0.05 <b>1.3</b>	3.7 0.15	0.248 <b>0.546</b>
LM 48548	LM 48511 A	*	SET 60	1.375 <b>34.925</b>	2.563 <b>65.088</b>	0.830 <b>21.082</b>	0.720 <b>18.288</b>	0.670 <b>17.018</b>		0.06 <b>1.5</b>		0.290 <b>0.638</b>
LM 48548 A	LM 48511 A	*	SET 59	34.925 <b>1.375</b>	2.563 <b>65.088</b>	0.830 <b>21.082</b>	0.720 <b>18.288</b>	0.670 <b>17.018</b>	0.8 <b>0.03</b>	0.06 <b>1.5</b>		0.280 <b>0.616</b>
LM 501349	LM 501310	A35	SET 45	1.625 <b>41.275</b>	2.891 <b>73.431</b>	0.771 <b>19.588</b>	0.780 <b>19.812</b>	0.580 <b>14.732</b>	0.14 <b>3.5</b>	0.03 <b>0.8</b>	3.3 0.13	0.327 <b>0.719</b>
LM 501349	LM 501314	*	SET 69	1.625 <b>41.275</b>	2.891 <b>73.431</b>	0.844 <b>21.430</b>	0.780 <b>19.812</b>	0.654 <b>16.604</b>	0.14 <b>3.5</b>	0.03 <b>0.8</b>		0.350 <b>0.770</b>
LM 603049	LM 603012	A 36	SET 36	1.781 <b>45.242</b>	3.063 <b>77.788</b>	0.844 <b>21.430</b>	0.781 <b>19.842</b>	0.656 <b>16.667</b>	0.14 <b>3.5</b>	0.03 <b>0.8</b>	2.2 0.09	0.381 <b>0.838</b>
LM 67045	LM 67010	A 29	SET 22	1.250 <b>31.75</b>	2.328 <b>59.131</b>	0.625 <b>15.875</b>	0.731 <b>18.57</b>	0.465 <b>11.811</b>		0.05 <b>1.3</b>	2.8 0.11	0.180 <b>0.396</b>
LM 67048	LM 67010	A 6	SET 6	1.250 <b>31.75</b>	2.328 <b>59.131</b>	0.625 <b>15.875</b>	0.660 <b>16.764</b>	0.465 <b>11.811</b>		0.05 <b>1.3</b>	2.8 0.11	0.180 <b>0.396</b>
LM 78349	LM 78310 A	*	*	1.378 <b>35</b>	2.441 <b>62</b>	0.657 <b>16.7</b>	0.669 <b>17</b>	0.535 <b>13.599</b>		0.06 <b>1.5</b>		0.222 <b>0.488</b>
M 12649	M 12610	A 3	SET 3	0.844 <b>21.43</b>	1.969 <b>50.005</b>	0.690 <b>17.526</b>	0.720 <b>18.288</b>	0.550 <b>13.97</b>	0.05 <b>1.3</b>	0.05 <b>1.3</b>	6.4 0.25	0.169 <b>0.372</b>
M 201047	M 201011	A7	SET 7	1.563 <b>39.688</b>	2.875 <b>73.025</b>	1.010 <b>25.654</b>	0.870 <b>22.098</b>	0.840 <b>21.336</b>	0.03 <b>0.8</b>	0.09 <b>2.3</b>	5.9 0.23	0.435 <b>0.957</b>
M 84249	M 84210	*	*	1.000 <b>25.4</b>	2.344 <b>59.53</b>	0.920 <b>23.368</b>	0.910 <b>23.114</b>	0.720 <b>18.288</b>	0.03 <b>0.8</b>	0.06 <b>1.5</b>		0.330 <b>0.726</b>
M 86647	M 86610	*	SET 65	1.125 <b>28.575</b>	2.531 <b>64.292</b>	0.844 <b>21.433</b>	0.844 <b>21.433</b>	0.656 <b>16.67</b>	0.06 <b>1.5</b>	0.06 <b>1.5</b>		0.348 <b>0.766</b>
M 86649	M 86610	*	*	1.187 <b>30.162</b>	2.531 <b>64.292</b>	0.844 <b>21.433</b>	0.844 <b>21.433</b>	0.656 <b>16.67</b>	0.06 <b>1.5</b>	0.06 <b>1.5</b>		0.336 <b>0.739</b>
M 88048	M 88010	*	SET 63	1.312 <b>33.338</b>	2.687 <b>68.262</b>	0.875 <b>22.225</b>	0.875 <b>22.225</b>	0.569 <b>14.462</b>	0.03 <b>0.8</b>	0.06 <b>1.5</b>		0.379



# Needle Bearings

## CAM Followers

Hexagonal wrench mounting

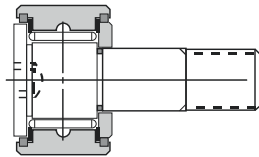

CRSB 8 to 10-1

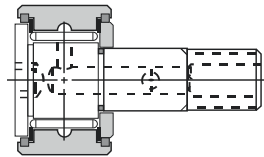

CRSB 24 to 44

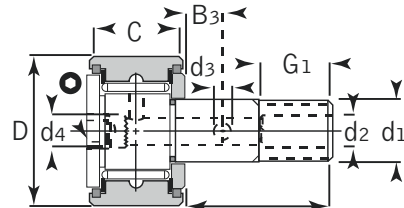

B<sub>2</sub>  
CRSB 12 to 22  
CRSB 48 to 64

### CRSB Dim.

Bearing Designation	Outside Diameter	Dimensions (inch) d1	D	C	B2	B3	G1	d4	d2	d3	G UNF
CRSB 8 CRSB 8-1	1/2	0.19	0.5	0.344 0.375	0.5 0.625	None	0.25	None	None	None	10 - 32
CRSB 10 CRSB 10-1	5/8	0.25	0.625	0.406 0.438	0.625 0.75	None	0.312	None	None	None	1/4 - 28
CRSB 12	3/4	0.375	0.75	0.5	0.875	0.25	0.375	0.188	0.188	0.094	3/8 - 24
CRSB 14	7/8	0.375	0.875	0.5	0.875	0.25	0.375	0.188	0.188	0.094	3/8 - 24
CRSB 16	1	0.4375	1	0.625	1	0.25	0.5	0.25	0.188	0.125	7/16 - 20
CRSB 18	1-1/8	0.4375	1.125	0.625	1	0.25	0.5	0.25	0.188	0.125	7/16 - 20
CRSB 20	1-1/4	0.5	1.25	0.75	1.25	0.312	0.625	0.25	0.188	0.125	1/2 - 20
CRSB 22	1-3/8	0.5	1.375	0.75	1.25	0.312	0.625	0.25	0.188	0.125	1/2 - 20
CRSB 24	1-1/2	0.625	1.5	0.875	1.5	0.375	0.75	None	0.188	0.094	5/8 - 18
CRSB 26	1-5/8	0.625	1.625	0.875	1.5	0.375	0.75	None	0.188	0.094	5/8 - 18
CRSB 28	1-3/4	0.75	1.75	1	1.75	0.438	0.875	None	0.188	0.094	3/4 - 16
CRSB 30	1-7/8	0.75	1.875	1	1.75	0.438	0.875	None	0.188	0.094	3/4 - 16
CRSB 32	2	0.875	2	1.25	2	0.5	1	None	0.188	0.125	7/8 - 14
CRSB 36	2-1/4	0.875	2.25	1.25	2	0.5	1	None	0.188	0.125	7/8 - 14
CRSB 40	2-1/2	1	2.5	1.5	2.5	0.562	1.125	None	0.188	0.125	1 - 14
CRSB 44	2-3/4	1	2.75	1.5	2.5	0.562	1.125	None	0.188	0.125	1 - 14
CRSB 48	3	1.25	3	1.75	2.5	0.625	1.25	0.25	0.25	0.125	1-1/4 - 12
CRSB 52	3-1/4	1.25	3.25	1.75	2.5	0.625	1.25	0.25	0.25	0.125	1-1/4 - 12
CRSB 56	3-1/2	1.375	3.5	2	2.75	0.688	1.375	0.25	0.25	0.125	1-3/8 - 12
CRSB 64	4	1.5	4	2.25	3.5	0.75	1.5	0.25	0.25	0.125	1-1/2 - 12

# Needle Bearings

## CAM Followers



● Hexagonal wrench mounting

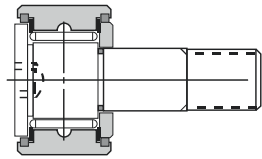

CRSB 8 to 10-1

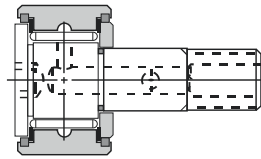

CRSB 24 to 44

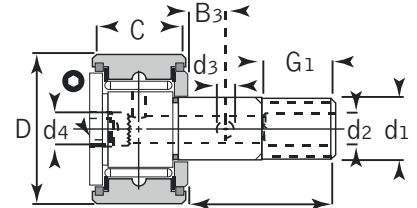

CRSB 12 to 22  
CRSB 48 to 64

## CRSB Mounting

Bearing Designation	Outside Diameter	Load Rating		Mounting Dimensions			Mounting Overhang Space		* Clamping Torque max. lbf / inch	Mass. Approx. Lbs
		Dynamic C lbf	Static C <sub>0</sub>	Limiting Speed Grease rpm	Bore Dia. for Stud ra max.		Ka min.	da min.		
CRSB 8	1/2	999	1 110	7 000	0.19	0.01	0.41	0.297	8	0.02
CRSB 8-1		1 120	1 280	7 000	0.19	0.01	0.44	0.297	8	0.023
CRSB 10	5/8	1 360	1 770	5 500	0.25	0.015	0.5	0.359	20	0.41
CRSB 10-1		1 480	1 970	5 500	0.25	0.015	0.5	0.359	20	0.045
CRSB 12	3/4	2 330	3 410	3 900	0.375	0.015	0.56	0.5	55	0.076
CRSB 14	7/8	2 330	3 410	3 900	0.375	0.015	0.56	0.5	5	0.097
CRSB 16	1	2 980	5 010	3 000	0.4375	0.03	0.69	0.641	150	0.161
CRSB 18	1-1/8	2 980	5 010	3 000	0.4375	0.03	0.69	0.641	150	0.197
CRSB 20	1-1/4	4 840	7 460	2 600	0.5	0.03	0.81	0.766	205	0.301
CRSB 22	1-3/8	4 840	7 460	2 600	0.5	0.03	0.81	0.766	205	0.354
CRSB 24	1-1/2	6 380	9 160	2 300	0.625	0.03	0.94	0.891	390	0.528
CRSB 26	1-5/8	6 380	9 160	2 300	0.625	0.03	0.94	0.891	390	0.605
CRSB 28	1-3/4	8 040	12 800	1 900	0.75	0.04	1.06	1.047	750	0.848
CRSB 30	1-7/8	8 040	12 800	1 900	0.75	0.04	1.06	1.047	750	0.947
CRSB 32	2	9 770	17 100	1 700	0.875	0.05	1.33	1.203	900	1.37
CRSB 36	2-1/4	9 780	17 100	1 700	0.875	0.05	1.33	1.203	900	1.67
CRSB 40	2-1/2	13 200	26 600	1 400	1	0.09	1.58	1.313	1350	2.5
CRSB 44	2-3/4	13 200	26 600	1 400	1	0.09	1.58	1.313	1350	2.93
CRSB 48	3	16 800	40 200	990	1.25	0.09	1.83	1.75	2050	4.2
CRSB 52	3-1/4	16 800	40 200	990	1.25	0.09	1.83	1.75	2050	4.81
CRSB 56	3-1/2	24 900	51 000	950	1.375	0.09	2.08	1.922	2500	6.42
CRSB 64	4	31 100	72 200	780	1.5	0.09	2.33	2.281	3000	9.46

\* Torque is based on lubricated threads. If threads are dry, the torque value listed above may be doubled.



# Track Roller

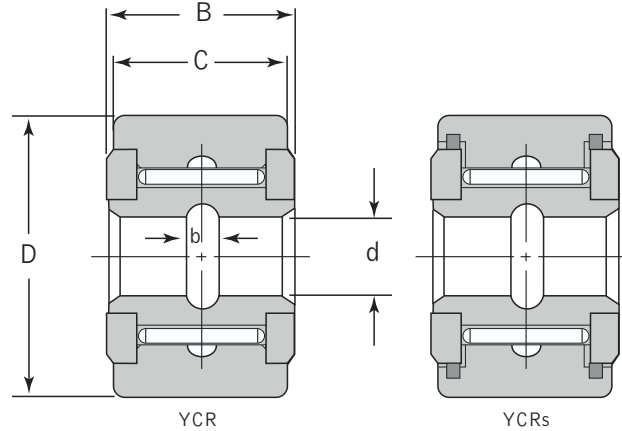

## YCRS Dim.

Bearing Designation		Outside Diameter	Dimensions			B	C	b
			-0.001	max.	min.			
Without Seals	With Seals		D		d			
YCR 12	YCRS 12	3/4	0.75	0.2502	0.2496	0.5625	0.5	0.125
YCR 14	YCRS 14	7/8	0.875	0.2502	0.2496	0.5625	0.5	0.125
YCR 16	YCRS 16	1	1	0.3127	0.3121	0.6875	0.625	0.125
YCR 18	YCRS 18	1-1/8	1.125	0.3127	0.3121	0.6875	0.625	0.125
YCR 20	YCRS 20	1-1/4	1.25	0.3752	0.3746	0.8125	0.75	0.188
YCR 22	YCRS 22	1-3/8	1.375	0.3752	0.3746	0.8125	0.75	0.188
YCR 24	YCRS 24	1-1/2	1.5	0.4377	0.4371	0.9375	0.875	0.125
YCR 26	YCRS 26	1-5/8	1.625	0.4377	0.4371	0.9375	0.875	0.125
YCR 28	YCRS 28	1-3/4	1.75	0.5002	0.4996	1.0625	1	0.125
YCR 30	YCRS 30	1-7/8	1.875	0.5002	0.4996	1.0625	1	0.125
YCR 32	YCRS 32	2	2	0.6252	0.6246	1.3125	1.25	0.125
YCR 36	YCRS 36	2-1/4	2.25	0.6252	0.6246	1.3125	1.25	0.125
YCR 40	YCRS 40	2-1/2	2.5	0.7502	0.7496	1.5625	1.5	0.145
YCR 44	YCRS 44	2-3/4	2.75	0.7502	0.7496	1.5625	1.5	0.145
YCR 48	YCRS 48	3	3	1.0001	0.9995	1.8125	1.75	0.145
YCR 52	YCRS 52	3-1/4	3.25	1.0001	0.9995	1.8125	1.75	0.145
YCR 56	YCRS 56	3-1/2	3.5	1.1251	1.1245	2.0625	2	0.145
YCR 64	YCRS 64	4	4	1.2501	1.2495	2.3125	2.25	0.145
-	YCRS 80	5	5	1.7501	1.7495	2.875	2.75	0.375
-	YCRS 96	6	6	2.2501	2.2495	3.375	3.25	0.375

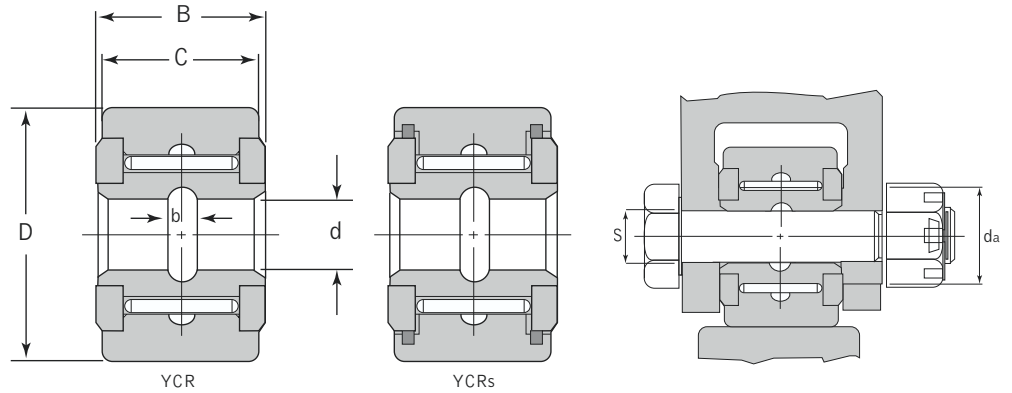

## YCRS Mounting

Bearing Designation		Load Rating		Limit Speed Grease	Mounting Dimensions Shaft				Clamping Diameter min. da	Mass. Approx. <b>lbs</b>
					Transition Fit Loose		Transition Fit Tight			
Without seals	With seals	Dynamic C	Static CO		Max.	Min.	Max.	Min.		
					f7		h6			
YCR 12	YCRS 12	2 330	3 410	3 900	0.2497	0.2493	0.2505	0.2501	0.5	0.06
YCR 14	YCRS 14	2 330	3 410	3 900	0.2497	0.2493	0.2505	0.2501	0.5	0.08
YCR 16	YCRS 16	2 980	5 010	3 000	0.3122	0.3118	0.313	0.3126	0.641	0.15
YCR 18	YCRS 18	2 980	5 010	3 000	0.3122	0.3118	0.313	0.3126	0.641	0.17
YCR 20	YCRS 20	4 840	7 460	2 600	0.3747	0.3743	0.3755	0.3751	0.766	0.3
YCR 22	YCRS 22	4 840	7 460	2 600	0.3747	0.3743	0.3755	0.3751	0.766	0.5
YCR 24	YCRS 24	6 380	9 160	2 300	0.4372	0.4368	0.438	0.4376	0.891	0.41
YCR 26	YCRS 26	6 380	9 160	2 300	0.4372	0.4368	0.438	0.4376	0.891	0.5
YCR 28	YCRS 28	8 040	12 800	1 900	0.4997	0.4993	0.5007	0.5003	1.047	0.64
YCR 30	YCRS 30	8 040	12 800	1 900	0.4997	0.4993	0.5007	0.5003	1.047	0.8
YCR 32	YCRS 32	9 770	17 100	1 700	0.6247	0.6243	0.6257	0.6253	1.203	1.05
YCR 36	YCRS 36	9 770	17 100	1 700	0.6247	0.6243	0.6257	0.6253	1.203	1.32
YCR 40	YCRS 40	13 200	26 600	1 400	0.7497	0.7493	0.7507	0.7503	1.313	1.8
YCR 44	YCRS 44	13 200	26 600	1 400	0.7497	0.7493	0.7507	0.7503	1.313	2.25
YCR 48	YCRS 48	16 800	40 200	990	0.9996	0.9991	1.0008	1.003	1.75	3.1
YCR 52	YCRS 52	16 800	40 200	990	0.9996	0.9991	1.0008	1.003	1.75	3.62
YCR 56	YCRS 56	24 900	51 000	950	1.1246	1.1241	1.1258	1.1253	1.922	4.95
YCR 64	YCRS 64	31 100	72 200	780	1.2496	1.2491	1.2508	1.2503	2.281	7.05
-	YCRS 80	33 800	-	700	1.7496	1.7491	1.7508	1.7503	2.875	13.2
-	YCRS 96	48 300	-	580	2.2496	2.2491	2.2508	2.2503	3.375	23.2



# Needle Bearings

## Inner Race

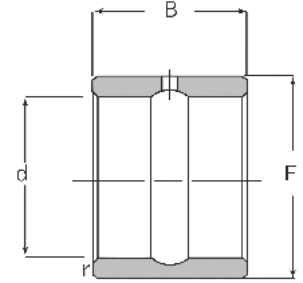
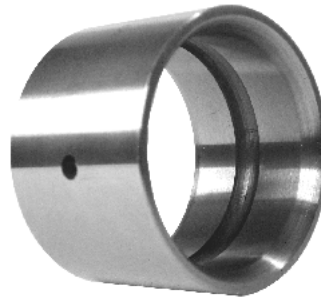

IR

Inner Ring Designation	Shaft Diameter	Dimensions				Mass Approx.	Used with Bearing No.
		d	F	B	rs min		
IR 061012	3/8	0.375	0.625	0.75	0.025	0.04	HJ 101812
IR 081212 IR 081216	1/2	0.5	0.75	0.75 1	0.04	0.05 0.07	HJ 122012 HJ 122016
IR 101412 IR 101416	5/8	0.625	0.875	0.75 1	0.04	0.06 0.08	HJ 142212 HJ 142216
IR 111412	11/16	0.6875	0.875	0.75	0.04	0.05	HJ 142212
IR 121612 IR 121616	3/4	0.75	1	0.75 1	0.04	0.07 0.09	HJ 162412 HJ 162416
IR 131616	13/16	0.8125	1	1	0.04	0.07	HJ 162416
IR 141816 IR 141820	7/8	0.875	1.125	1 1.25	0.04	0.11 0.13	HJ 182616 HJ 182620
IR 151816 IR 151820	15/16	0.9375	1.125	1 1.25	0.04	0.08 0.1	HJ 182616 HJ 182620
IR 162016 IR 162020	1	1	1.25	1 1.25	0.04	0.12 0.05	HJ 202816 HJ 202820
IR 182216 IR 182220	1-1/8	1.125	1.375	1 1.25	0.04	0.13 0.17	HJ 223016 HJ 223020
IR 192420	1-3/16	1.1875	1.5	1.25	0.06	0.22	HJ 243320
IR 202416 IR 202420	1-1/4	1.25	1.5	1 1.25	0.06	0.15 0.18	HJ 243316 HJ 243320
IR 212616 IR 212620	1-5/16	1.3125	1.625	1 1.25	0.06	0.19 0.24	HJ 263516 HJ 263520
IR 222620 IR 222820	1-3/8	1.375	1.625 1.75	1.25	0.06	0.2 0.31	HJ 263520 HJ 283720
IR 232816 IR 232820	1-7/16	1.4375	1.75	1 1.25	0.06	0.21 0.26	HJ 283716 HJ 283720
IR 242816 IR 242820 IR 243320	1-1/2	1.5	1.75 2	1 1.25	0.06	0.17 0.21 0.46	HJ 283716 HJ 283720 HJ 324120
IR 253020 IR 253220	1-9/16	1.5625	1.875 2	1.25	0.06	0.28 0.41	HJ 303920 HJ 324120
IR 263220	1-5/8	1.625	2	1.25	0.06	0.36	HJ 324120
IR 273216 IR 273220	1-11/16	1.6875	2	1 1.25	0.06	0.24 0.3	HJ 324116 HJ 324120
IR 283624 IR 283628	1-3/4	1.75	2.25	1.5 1.75	0.06	0.63 0.74	HJ 364824 HJ 364828
IR 314024 IR 314028	1-15/16	1.9375	2.5	1.5 1.75	0.08	0.79 0.92	HJ 405224 HJ 405228

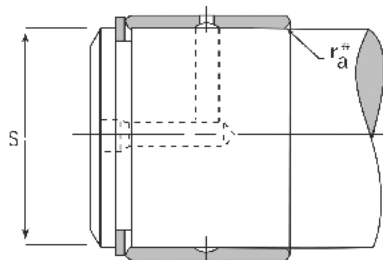

IR with Shaft

# Needle Bearings

## Inner Race



Shaft diameter	Dimensions				S - Loose Transition Fit Shaft Diameter		S - Interference Fit Shaft Diameter		Inner Ring Designation	Used with Bearing No.	Mass Approx.
	d	F	B	ra min	Max.	Min.	Max.	Min.			
3/8	0.3750	0.6250	0.750	0.025	0.3748	0.3744	0.3755	0.3752	IR 061012	HJ 101812	0.04
1/2	0.5000	0.7500	0.750	0.04	0.4997	0.4993	0.5006	0.5003	IR 081212	HJ 122012	0.05
	0.5000	0.7500	1.000	0.04	0.4997	0.4993	0.5006	0.5003	IR 081216	HJ 122016	0.07
5/8	0.6250	0.8750	0.750	0.04	0.6247	0.6243	0.6256	0.6253	IR 101412	HJ 142212	0.06
	0.6250	0.8750	1.000	0.04	0.6247	0.6243	0.6256	0.6253	IR 101416	HJ 142216	0.08
11/16	0.6875	0.8750	0.750	0.04	0.6872	0.6868	0.6881	0.6878	IR 111412	HJ 142212	0.05
3/4	0.7500	1.0000	0.750	0.04	0.7497	0.7492	0.7507	0.7503	IR 121612	HJ 162412	0.07
	0.7500	1.0000	1.000	0.04	0.7497	0.7492	0.7507	0.7503	IR 121616	HJ 162416	0.09
13/16	0.8125	1.0000	1.000	0.04	0.8122	0.8117	0.8132	0.8128	IR 131616	HJ 162416	0.07
7/8	0.8750	1.1250	1.000	0.04	0.8747	0.8742	0.8757	0.8753	IR 141816	HJ 182616	0.11
	0.8750	1.1250	1.250	0.04	0.8747	0.8742	0.8757	0.8753	IR 141820	HJ 182620	0.13
15/16	0.9375	1.1250	1.000	0.04	0.9372	0.9367	0.9882	0.9378	IR 151816	HJ 182616	0.08
	0.9375	1.1250	1.250	0.04	0.9372	0.9367	0.9882	0.9378	IR 151820	HJ 182620	0.10
1	1.0000	1.2500	1.000	0.04	0.9997	0.9992	1.0007	1.0003	IR 162016	HJ 202816	0.12
	1.0000	1.2500	1.250	0.04	0.9997	0.9992	1.0007	1.0003	IR 162020	HJ 202820	0.05
1-1/8	1.1250	1.3750	1.000	0.04	1.1247	1.1242	1.1257	1.1253	IR 182216	HJ 223016	0.13
	1.1250	1.3750	1.250	0.04	1.1247	1.1242	1.1257	1.1253	IR 182220	HJ 223020	0.17
1-3/16	1.1875	1.5000	1.250	0.06	1.1872	1.1867	1.1882	1.1878	IR 192420	H J 243320	0.22
1-1/4	1.2500	1.5000	1.000	0.06	1.2496	1.2490	1.2508	1.2504	IR 202416	HJ 243316	0.15
	1.2500	1.5000	1.250	0.06	1.2496	1.2490	1.2508	1.2504	IR 202420	HJ 243320	0.18
1-5/16	1.3125	1.6250	1.000	0.06	1.3121	1.3115	1.3133	1.3129	IR 212616	HJ 263516	0.19
	1.3125	1.6250	1.250	0.06	1.3121	1.3115	1.3133	1.3129	IR 212620	HJ 263520	0.24
1-3/8	1.3750	1.6250	1.250	0.06	1.3746	1.3740	1.3758	1.3754	IR 222620	HJ 263520	0.20
	1.3750	1.7500	1.250	0.06	1.3746	1.3740	1.3758	1.3754	IR 222820	HJ 283720	0.31
1-7/16	1.4375	1.7500	1.000	0.06	1.4371	1.4365	1.4383	1.4379	IR 232816	HJ 283716	0.21
	1.4375	1.7500	1.250	0.06	1.4371	1.4365	1.4383	1.4379	IR 232820	HJ 283720	0.26
1-1/2	1.5000	1.7500	1.000	0.06	1.4996	1.4990	1.5008	1.5004	IR 242816	HJ 283716	0.17
	1.5000	1.7500	1.250	0.06	1.4996	1.4990	1.5008	1.5004	IR 242820	HJ 283720	0.21
	1.5000	2.0000	1.250	0.06	1.4996	1.4990	1.5008	1.5004	IR 243320	HJ 324120	0.46
1-9/16	1.5625	1.8750	1.250	0.06	1.5621	1.5615	1.5633	1.5629	IR 253020	HJ 303920	0.28
	1.5625	2.0000	1.250	0.06	1.5621	1.5615	1.5633	1.5629	IR 253220	HJ 324120	0.41
1-5/8	1.6250	2.0000	1.250	0.06	1.6246	1.6240	1.6258	1.6254	IR 263220	HJ 324120	0.36
1-11/16	1.6875	2.0000	1.000	0.06	1.6871	1.6865	1.6883	1.6879	IR 273216	HJ 324116	0.24
	1.6875	2.0000	1.250	0.06	1.6871	1.6865	1.6883	1.6879	IR 273220	HJ 324120	0.30
1-3/4	1.7500	2.2500	1.500	0.06	1.7496	1.7490	1.7508	1.7504	IR 283624	HJ 364824	0.63
	1.7500	2.2500	1.750	0.06	1.7496	1.7490	1.7508	1.7504	IR 283628	HJ 364828	0.74
1-15/16	1.9375	2.5000	1.500	0.08	1.9371	1.9365	1.9383	1.9397	IR 314024	HJ 405224	0.79
	1.9375	2.5000	1.750	0.08	1.9371	1.9365	1.9383	1.9379	IR 314028	HJ 405228	0.92



# Needle Bearings

## Inner Race

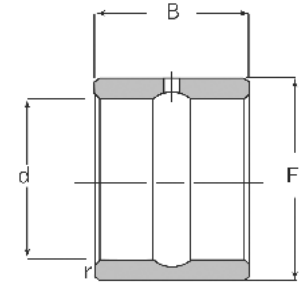
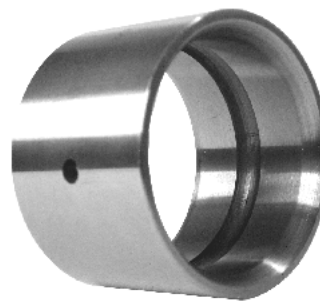

IR

Inner Ring Designation	Shaft Diameter	Dimensions				Mass Approx.	Used with Bearing No.
		d	F	Brs	Min		
IR 324024 IR 324028	2	2	2.5	1.5 1.75	0.08	0.71 0.83	HJ 405224 HJ 405228
IR 354428	2-3/16	2.1875	2.75	1.75	0.08	1.03	HJ 445628
IR 364424 IR 364428	2-1/4	2.25	2.75	1.5 1.75	0.08	0.79 0.92	HJ 445624 HJ 445628
IR 384828	2-3/8	2.375	3	1.75	0.08	1.24	HJ 486028
IR 404824 IR 404828	2-1/2	2.5 2.5	3 3	1.5 1.75	0.08 0.08	0.87 1.02	HJ 486024 HJ 486028
IR 445228 IR 445232	2-3/4	2.75 2.75	3.25 3.25	1.75 2	0.08 0.08	1.11 1.27	HJ 526828 HJ 526832
IR 475632	2-15/16	2.9375	3.5	2	0.08	1.53	HJ 567232
IR 485632	3	3	3.5	2	0.08	1.37	HJ 567232
IR 506032	3-1/8	3.125	3.75	2	0.1	*	HJ 607632
IR 526032 IR 526432	3-1/4	3.25	3.75 4	2 2	0.1 0.1	* *	HJ 607632 HJ 648032
IR 566432	3-3/8	3.375	4	2	0.1	*	HJ 648032
IR 566432 IR 566832	3-1/2	3.5	4 4.25	2	0.1	* *	HJ 648032 HJ 688432
IR 606832 IR 607236 IR 607240	3-3/4	3.75	4.25 4.5	2 2.25 2.5	0.1	* * *	HJ 688432 HJ 729636 HJ 729640
IR 648036 IR 648040	4	4	5	2.25 2.5	0.1	* *	HJ 8010436 HJ 8010440
IR 688036	4-1/4	4.25	5	2.25	0.1	*	HJ 8010436
IR 728840 IR 728848	4-1/2	4.5	5.5	2.5 3	0.1	* *	HJ 8811240 HJ 8811248
IR 799248	4-3/4	4.75	5.75	3	0.12	*	HJ 9211648
IR 809640 IR 809648	5	5	6	2.5 3	0.12	* *	HJ 9612040 HJ 9612048
IR 8810440 IR 8810448	5-1/2	5.5	6.5	2.5 3	0.12	* *	HJ 10412840 HJ 10412848
IR 9611648	6	6	7.25	3	0.12	*	HJ 11614648
IR 10412448	6-1/2	6.5	7.75	3	0.12	*	HJ 12415448
IR 11213248	7	7	8.25	3	0.12	*	HJ 13216248
IR 12014048	7-1/2	7.5	8.75	3	0.16	*	HJ 14017048
IR 12814848	8	8	9.25	3	0.16	*	HJ 14817848



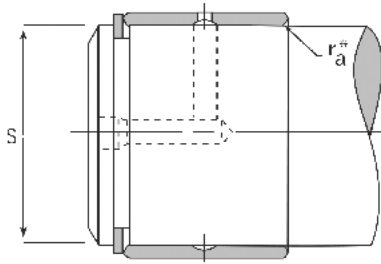

IR with Shaft

# Needle Bearings

## Inner Race



Shaft Diameter	Dimensions				S - Loose Transition Fit Shaft Diameter		S - Interference Fit Shaft Diameter		Inner Ring Designation	Used with Bearing No.	Mass Approx.
	d	F	B	ra min	Max.	Min.	Max.	Min.			
2	2.0000	2.5000	1.500	0.08	1.9996	1.9989	2.0009	2.0004	IR 324024	HJ 405224	0.71
	2.0000	2.5000	1.750	0.08	1.9996	1.9989	2.0009	2.0004	IR 324028	HJ 405228	0.83
2-3/16	2.1875	2.7500	1.750	0.08	2.1871	2.1964	2.1884	2.1879	IR 354428	HJ 445628	1.03
2-1/4	2.2500	2.7500	1.500	0.08	2.2496	2.2489	2.2509	2.2504	IR 364424	HJ 445624	0.79
	2.2500	2.7500	1.750	0.08	2.2496	2.2489	2.2509	2.2504	IR 364428	HJ 445628	0.92
2-3/8	2.3750	3.0000	1.750	0.08	2.3746	2.3739	2.3759	2.3754	IR 384828	HJ 486028	1.24
2-1/2	2.5000	3.0000	1.500	0.08	2.4996	2.4989	2.5009	2.5004	IR 404824	HJ 486024	0.87
	2.5000	3.0000	1.750	0.08	2.4996	2.4989	2.5009	2.5004	IR 404828	HJ 486028	1.02
2-3/4	2.7500	3.2500	1.750	0.08	2.7496	2.7489	2.7509	2.7504	IR 445228	HJ 526828	1.11
	2.7500	3.2500	2.000	0.08	2.7496	2.7489	2.7509	2.7504	IR 445232	HJ 526832	1.27
2-15/16	2.9375	3.5000	2.000	0.08	2.9371	2.9364	2.9384	2.9379	IR 475632	HJ 567232	1.53
3	3.0000	3.5000	2.000	0.08	2.9996	2.9989	3.0009	3.0004	IR 485632	HJ 567232	1.37
3-1/8	3.125	3.7500	2.000	0.10	3.1246	3.1239	3.1259	3.1254	IR 506032	HJ 607632	*
3-1/4	3.2500	3.7500	2.000	0.10	3.2495	3.2487	3.2511	3.2505	IR 526032	HJ 607632	*
		4.0000	2.000	0.10	3.2495	3.2487	3.2511	3.2505	IR 526432	HJ 648032	*
3-3/8	3.3750	4.0000	2.000	0.10	3.3745	3.3737	3.3761	3.3755	IR 566432	HJ 648032	*
3-1/2	3.5000	4.0000	2.000	0.10	3.4995	3.4987	3.5011	3.5005	IR 566432	HJ 648032	*
	3.5000	4.2500	2.000	0.10	3.4995	3.4987	3.5011	3.5005	IR 566832	HJ 688432	*
3-3/4	3.7500	4.2500	2.000	0.10	3.7495	3.7487	3.7511	3.7505	IR 606832	HJ 688432	*
	3.7500	4.5000	2.250	0.10	3.7495	3.7487	3.7511	3.7505	IR 607236	HJ 729636	*
	3.7500	4.5000	2.500	0.10	3.7495	3.7487	3.7511	3.7505	IR 607240	HJ 729640	*
4	4.0000	5.0000	2.250	0.10	3.9995	3.9987	4.0011	4.0005	IR 648036	HJ 8010436	*
			2.500	0.10	3.9995	3.9987	4.0011	4.0005	IR 648040	HJ 8010440	*
4-1/4	4.2500	5.0000	2.250	0.10	4.2495	4.2487	4.2511	4.2505	IR 688036	HJ 8010436	*
4-1/2	4.5000	5.5000	2.500	0.10	4.4995	4.4987	4.5011	4.5005	IR 728840	HJ 8811240	*
			3.000	0.10	4.4995	4.4987	4.5011	4.5005	IR 728848	HJ 8811248	*
4-3/4	4.7500	5.7500	3.000	0.12	4.7494	4.7485	4.7513	4.7506	IR 799248	HJ 9211648	*
5	5.0000	6.0000	2.500	0.12	4.9994	4.9985	5.0013	5.0006	IR 809640	HJ 9612040	*
			3.000	0.12	4.9994	4.9985	5.0013	5.0006	IR 809648	HJ 9612048	*
5-1/2	5.5000	6.5000	2.500	0.12	5.4994	5.4985	5.5013	5.5006	IR 8810440	HJ 10412840	*
		6.5000	3.000	0.12	5.4994	5.4985	5.5013	5.5006	IR 8810448	HJ 10412848	*
6	6.0000	7.2500	3.000	0.12	5.9994	5.9985	6.0013	6.0006	IR 9611648	HJ 11614648	*
6-1/2	6.5000	7.7500	3.000	0.12	6.4994	6.4985	6.5013	6.5006	IR 10412448	HJ 12415448	*
7	7.0000	8.2500	3.000	0.12	6.9994	6.9985	7.0013	7.0006	IR 11213248	HJ 13216248	*
7-1/2	7.5000	8.7500	3.000	0.16	7.4994	7.4982	7.5014	7.5006	IR 12014048	HJ 14017048	*
8	8.0000	9.2500	3.000	0.16	7.9994	7.9982	8.0014	8.0006	IR 12814848	HJ 14817848	*



# Needle Bearings

## HJ/IR

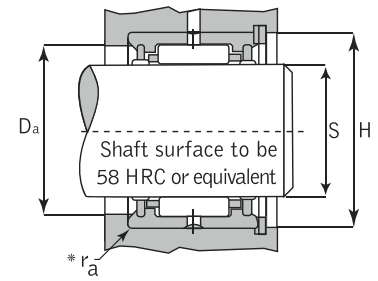

Bearing Designation	Shaft dia.	Dimensions				Load Ratings		Limit Speed		Weight lbs	Used with Inner Ring Designation
		Fw	D	C/B	rs min	Basic Dynamic	Basic Static	Grease (rpm)	Oil (rpm)		
HJ 101812	5/8	0.6250	1.1250	0.750	0.025	4350	4650	20000	30000	0.11	IR 061012
HJ 122012 HJ 122016	3/4	0.7500 0.7500	1.2500 1.2500	0.750 1.000	0.040 0.040	4650 6190	5240 7580	16000 16000	25000 25000	0.13 0.17	IR 081212 IR 081216
HJ 142212 HJ 142216	7/8	0.8750 0.8750	1.3750 1.3750	0.750 1.000	0.040 0.040	5180 6910	6270 9070	13000 13000	21000 21000	0.14 0.19	IR 101412 IR 111412 IR 101416
HJ 162412 HJ 162416	1	1.0000 1.0000	1.5000 1.5000	0.750 1.000	0.040 0.040	5180 7560	6270 10600	12000 12000	18000 18	0.16 0.21	IR 101412 IR 111412 IR 131616
HJ 182616 HJ 182620	1-1/8	1.1250 1.1250	1.6250 1.6250	1.000 1.125	0.040 0.040	8170 10100	12100 15800	1000 10000	1600 16000	0.23 0.29	IR 141816 IR 151816 IR 141820 IR 151820
HJ 202816 HJ 202820	1-1/4	1.2500 1.2500	1.7500 1.7500	1.000 1.250	0.040 0.040	8410 10400	12900 16900	9100 9100	14000 14000	0.25 0.32	IR 162016 IR 162020
HJ 223016 HJ 223020	1/38	1.3750 1.3750	1.8750 1.8750	1.000 1.250	0.040 0.040	8950 11100	14400 18900	8200 8200	13000 13000	0.28 0.35	IR 182216 IR 182220
HJ 243316 HJ 243320	1/1/2	1.5000 1.5000	2.0625 2.0625	1.000 1.250	0.060 0.060	10700 13200	16300 21400	7600 7600	12000 12000	0.34 0.43	IR 202416 IR 192420 IR 202420
HJ 263516 HJ 263520	1-5/8	1.6250 1.6250	2.1875 2.1875	1.000 1.250	0.060 0.060	10900 13500	17200 22600	7000 7000	11000 11000	0.36 0.46	IR 212616 IR 212620 IR 222620
HJ 283716 HJ 283720	1-3/4	1.7500 1.7500	2.3125 2.3150	1.000 1.250	0.060 0.060	11200 13900	18200 23900	6400 6400	9900 9900	0.39 0.49	IR 232816 IR 242816 IR 222820 IR 232820 IR 242820
HJ 303920	1-7/8	1.8750	2.4375	1.250	0.060	14700	26300	6000	9200	0.52	IR 253020

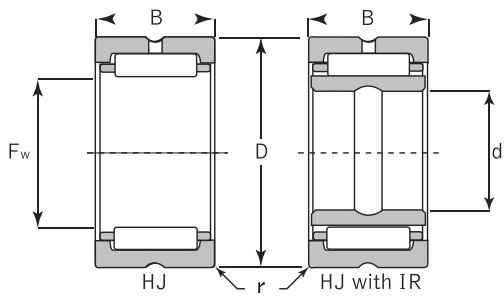

# Needle Bearings

## HJ/IR



Shaft Dia.	Dimensions				Bearing Designation	Used with Inner Ring Designation	Load Ratings		Limit Speed		Weight lbs
	Fw	D	C/B	rs min			Basic Dynamic	Basic Static	Grease (rpm)	Oil (rpm)	
5/8	0.6250	1.1250	0.750	0.025	HJ 101812	IR 061012	4350	4650	20000	30000	0.11
3/4	0.7500	1.2500	0.750	0.040	HJ 122012	IR 081212	4650	5240	16000	25000	0.13
	0.7500	1.2500	1.000	0.040	HJ 122016	IR 081216	6190	7580	16000	25000	0.17
7/8	0.8750	1.3750	0.750	0.040	HJ 142212	IR 101412	5180	6270	13000	21000	0.14
	0.8750	1.3750	1.000	0.040	HJ 142216	IR 101416					
1	1.0000	1.5000	0.750	0.040	HJ 142212	IR 101412	5180	6270	12000	18000	0.16
	1.0000	1.5000	1.000	0.040		IR 111412	7560	10600	12000	18	0.21
						IR 131616					
1-1/8	1.1250	1.6250	1.000	0.040	HJ 182616	IR 141816	8170	12100	1000	1600	0.23
						IR 151816					
	1.1250	1.6250	1.125	0.040	HJ 182620	IR 141820	10100	15800	10000	16000	0.29
					IR 151820						
1-1/4	1.2500	1.7500	1.000	0.040	HJ 202816	IR 162016	8410	12900	9100	14000	0.25
	1.2500	1.7500	1.250	0.040	HJ 202820	IR 162020	10400	16900	9100	14000	0.32
1/38	1.3750	1.8750	1.000	0.040	HJ 223016	IR 182216	8950	14400	8200	13000	0.28
	1.3750	1.8750	1.250	0.040	HJ 223020	IR 182220	11100	18900	8200	13000	0.35
1-1/2	1.5000	2.0625	1.000	0.060	HJ 243316	IR 202416	10700	16300	7600	12000	0.34
	1.5000	2.0625	1.250	0.060	HJ 243320	IR 192420	13200	21400	7600	12000	0.43
						IR 202420					
1-5/8	1.6250	2.1875	1.000	0.060	HJ 263516	IR 212616	10900	17200	7000	11000	0.36
	1.6250	2.1875	1.250	0.060	HJ 263520	IR 212620	13500	22600	7000	11000	0.46
						IR 222620					
1-3/4	1.7500	2.3125	1.000	0.060	HJ 283716	IR 232816	11200	18200	6400	9900	0.39
						IR 242816					
	1.7500	2.3150	1.250	0.060	HJ 283720	IR 222820	13900	23900	6400	9900	0.49
						IR 232820					
					IR 242820						
1-7/8	1.8750	2.4375	1.250	0.060	HJ 303920	IR 253020	14700	26300	6000	9200	0.52



# Needle Bearings

## HJ/IR

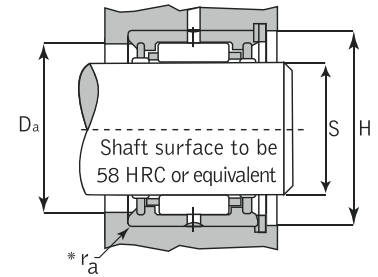

Bearing Designation	Shaft Dia.	Dimensions				Load Ratings		Limit Speed		Weight <b>lbs</b>	Used with Inner Ring Designation
		Fw	D	C/B	rs min	Basic Dynamic	Basic Static	Grease (rpm)	Oil (rpm)		
HJ 324116 HJ 324120	2	2.0000 2.0000	2.5625 2.5625	1.000 1.250	0.060 0.060	12100 15000	20900 27500	5600 5600	8600 8600	0.44 0.55	IR 273216 IR 243220 IR 253220 IR 263220 IR 273220
HJ 364824 HJ 364828	2-1/4	2.2500 2.2500	3.0000 3.0000	1.500 1.750	0.060 0.060	20200 23400	36900 44500	5000 5000	7600 7600	1.01 1.17	IR 283624 IR 283628
HJ 405224 HJ 405228	2-1/2	2.5000 2.5000	3.2500 3.2500	1.500 1.750	0.080 0.080	21800 25200	42100 50800	4400 4400	6800 6800	1.10 1.29	IR 314024 IR 324024 IR 314028 IR 324028
HJ 445616 HJ 445624 HJ 445628	2-3/4	2.7500 2.7500 2.7500	3.5000 3.5000 3.5000	1.000 1.500 1.750	0.080 0.080 0.080	15100 22700 26300	27000 45700 55100	4000 4000 4000	6200 6200 6200	0.80 1.20 1.40	IR 364424 IR 354428 IR 364428
HJ 486024 HJ 486028	3	3.0000 3.0000	3.7500 3.7500	1.500 1.750	0.080 0.080	24100 43900	50900 86000	3700 3700	5600 5600	1.29 1.51	IR 404824 IR 384828 IR 404828
HJ 526828 HJ 526832	3-1/4	3.2500 3.2500	4.2500 4.2500	1.750 2.000	0.080 0.080	36400 41300	68600 80500	3400 3400	5300 5300	2.24 2.56	IR 445228 IR 445232
HJ 567232	3-1/2	3.5000	4.5000	2.000	0.080	42000	84300	3200	4900	2.73	IR 475632 IR 485632
HJ 607632	3-3/4	3.7500	4.7500	2.000	0.100	44200	91000	4540	4375	3.208	IR 506032 IR 526032
HJ 648032	4	4.0000	5.0000	2.000	0.100	46000	98000	4230	4625	3.397	IR 526432 IR 546432 IR 566432
HJ 688432	4-1/4	4.2500	5.2500	2.000	0.100	46500	102000	3970	4875	3.586	IR 566832 IR 606832
HJ 729636 HJ 729640	4-1/2	4.5000 4.5000	6.0000 6.0000	2.250 2.500	0.100 0.100	64400 71700	116000 134000	3850 3850	5438 5438	6.691 7.434	IR 607236 IR 607240

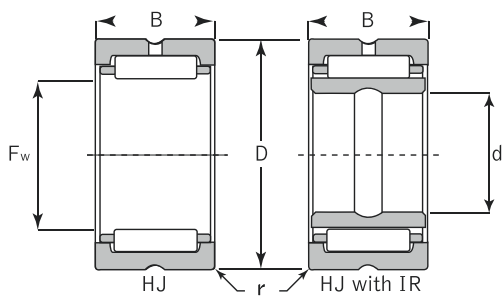

# Needle Bearings

## HJ/IR



Shaft Dia.	Dimensions				Bearing Designation	Used with Inner Ring Designation	Load Ratings		Limit Speed		Weight
	Fw	D	C/B	rs min			Basic Dynamic	Basic Static	Grease (rpm)	Oil (rpm)	lbs
2	2.0000	2.5625	1.000	0.060	HJ 324116	IR 273216	12100	20900	5600	8600	0.44
	2.0000	2.5625	1.250	0.060	HJ 324120	IR 243220	15000	27500	5600	8600	0.55
						IR 253220					
						IR 263220					
2-1/4	2.2500	3.0000	1.500	0.060	HJ 364824	IR 283624	20200	36900	5000	7600	1.01
	2.2500	3.0000	1.750	0.060	HJ 364828	IR 283628	23400	44500	5000	7600	1.17
2-1/2	2.5000	3.2500	1.500	0.080	HJ 405224	IR 314024	21800	42100	4400	6800	1.10
						IR 324024					
	2.5000	3.2500	1.750	0.080	HJ 405228	IR 314028	25200	50800	4400	6800	1.29
						IR 324028					
2-3/4	2.7500	3.5000	1.000	0.080	HJ 445616		15100	27000	4000	6200	0.80
	2.7500	3.5000	1.500	0.080	HJ 445624	IR 364424	22700	45700	4000	6200	1.20
	2.7500	3.5000	1.750	0.080	HJ 445628	IR 354428	26300	55100	4000	6200	1.40
						IR 364428					
3	3.0000	3.7500	1.500	0.080	HJ 486024	IR 404824	24100	50900	3700	5600	1.29
	3.0000	3.7500	1.750	0.080	HJ 486028	IR 384828	43900	86000	3700	5600	1.51
						IR 404828					
3-1/4	3.2500	4.2500	1.750	0.080	HJ 526828	IR 445228	36400	68600	3400	5300	2.24
	3.2500	4.2500	2.000	0.080	HJ 526832	IR 445232	41300	80500	3400	5300	2.56
3-1/2	3.5000	4.5000	2.000	0.080	HJ 567232	IR 475632	42000	84300	3200	4900	2.73
						IR 485632					
3-3/4	3.7500	4.7500	2.000	0.100	HJ 607632	IR 506032	44200	91000	4540	4375	3.38
						IR 526032					
4	4.0000	5.0000	2.000	0.100	HJ 648032	IR 526432	46000	98000	4230	4625	3.56
						IR 546432					
						IR 566432					
4-1/4	4.2500	5.2500	2.000	0.100	HJ 688432	IR 566832	46500	102000	3970	4875	3.74
						IR 606832					
4-1/2	4.5000	6.0000	2.250	0.100	HJ 729636	IR 607236	64400	116000	3850	5438	6.02
	4.5000	6.0000	2.500	0.100	HJ 729640	IR 607240	71700	134000	3850	5438	6.71



# Needle Bearings

HJ-RS / HJ-2RS



Bearing Designation		Dimensions					Load Ratings				Used with Inner Ring No.
One Seal	Two Seals	Shaft Diameter	Fw	D	C/B	rs min	Basic Dynamic C	Basic Static C0	Limiting Speed RPM	Mass Approx. <b>lbs</b>	
							lbf				
HJ 101816 RS	HJ 101816 2RS	5/8	0.625	1.125	1	0.025	4 350	4 650	6 100	0.15	
HJ 122016 RS	HJ 122016 2RS	3/4	0.75	1.25	1	0.04	4 650	5 240	5 100	0.17	IR 081216
HJ 142216 RS	HJ 142216 2RS	7/8	0.875	1.375	1	0.04	5 180	6 270	4 400	0.19	IR 101416
HJ 162416 RS	HJ 162416 2RS	1	1	1.5	1	0.04	5 680	7 300	3 800	0.21	IR 121616 IR 131616
HJ 182620 RS	HJ 182620 2RS	1-1/8	1.125	1.625	1.25	0.04	8 170	12 100	3 400	0.29	IR 141820 IR 151820
HJ 202820 RS	HJ 202820 2RS	1-1/4	1.25	1.75	1.25	0.04	8 410	12 900	3 100	0.32	IR 162020
HJ 223020 RS	HJ 223020 2RS	1-3/8	1.375	1.875	1.25	0.04	8 950	14 400	2 800	0.35	IR 182220
HJ 243320 RS	HJ 243320 2RS	1-1/2	1.5	2.0625	1.25	0.06	10 700	16 300	2 500	0.43	IR 192420 IR 202420
HJ 263520 RS	HJ 263520 2RS	1-5/8	1.625	2.1875	1.25	0.06	10 900	17 200	2 400	0.46	IR 212620
HJ 283720 RS	HJ 283720 2RS	1-3/4	1.75	2.3125	1.25	0.06	11 200	18 200	2 200	0.49	IR 222820 IR 232820 IR 242820
HJ 324120 RS	HJ 324120 2RS	2	2	2.5625	1.25	0.06	12 100	20 900	1 900	0.55	IR 243320 IR 253220 IR 263220 IR 273220
HJ 364828 RS	HJ 364828 2RS	2-1/4	2.25	3	1.75	0.06	20 200	36 900	1 700	1.17	IR 283628
HJ 405228 RS	HJ 405228 2RS	2-1/2	2.5	3.25	1.75	0.08	21 800	42 100	1 500	1.29	IR 222620 IR 314028 IR 324028
HJ 445628 RS	HJ 445628 2RS	2-3/4	2.75	3.5	1.75	0.08	22 700	45 700	1 400	1.4	IR 354428 IR 364428
HJ 486028 RS	HJ 486028 2RS	3	3	3.75	1.75	0.08	24 100	50 900	1 300	1.51	IR 384828 IR 404828

† See pages XXX for inch series inner ring. Inner rings must be ordered separately

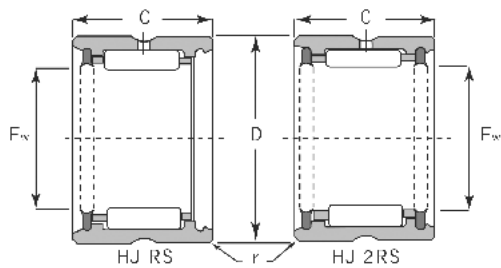

# Needle Bearings

## HJ/IR



Dimensions					Bearing Designation		Used with Inner Ring No.†	Load Ratings			
Shaft Diameter	Fw (inch)	D	C/B	rs min						Basic Dynamic C	Basic Dynamic C0
					One seal	Two seals		lbf			
5/8	0.6250	1.1250	1.000	0.025	HJ 101816 RS	HJ 101816 2RS		4 350	4 650	6 100	0.15
3/4	0.7500	1.2500	1.000	0.04	HJ 122016 RS	HJ 122016 2RS	IR 081216	4 650	5 240	5 100	0.17
7/8	0.8750	1.3750	1.000	0.04	HJ 142216 RS	HJ 142216 2RS	IR 101416	5 180	6 270	4 400	0.19
1	1.0000	1.5000	1.000	0.04	HJ 162416 RS	HJ 162416 2RS	IR 121616	5 680	7 300	3 800	0.21
							IR 131616				
1-1/8	1.1250	1.6250	1.250	0.04	HJ 182620 RS	HJ 182620 2RS	IR 141820	8 170	12 100	3 400	0.29
							IR 151820				
1-1/4	1.2500	1.7500	1.250	0.04	HJ 202820 RS	HJ 202820 2RS	IR 162020	8 410	12 900	3 100	0.32
1-3/8	1.3750	1.8750	1.250	0.04	HJ 223020 RS	HJ 223020 2RS	IR 182220	8 950	14 400	2 800	0.35
1-1/2	1.5000	2.0625	1.250	0.06	HJ 243320 RS	HJ 243320 2RS	IR 192420	10 700	16 300	2 500	0.43
							IR 202420				
1-5/8	1.6250	2.1875	1.250	0.06	HJ 263520 RS	HJ 263520 2RS	IR 212620	10 900	17 200	2 400	0.46
1-3/4	1.7500	2.3125	1.250	0.06	HJ 283720 RS	HJ 283720 2RS	IR 222820	11 200	18 200	2 200	0.49
							IR 232820				
							IR 242820				
2	2.0000	2.5625	1.250	0.06	HJ 324120 RS	HJ 324120 2RS	IR 243320	12 100	20 900	1 900	0.55
							IR 253220				
							IR 263220				
							IR 273220				
2-1/4	2.2500	3.0000	1.750	0.06	HJ 364828 RS	HJ 364828 2RS	IR 283628	20 200	36 900	1 700	1.17
2-1/2	2.5000	3.2500	1.750	0.08	HJ 405228 RS	HJ 405228 2RS	IR 222620	21 800	42 100	1 500	1.29
							IR 314028				
							IR 324028				
2-3/4	2.7500	3.5000	1.750	0.08	HJ 445628 RS	HJ 445628 2RS	IR 354428	22 700	45 700	1 400	1.40
							IR 364428				
3	3.0000	3.7500	1.750	0.08	HJ 486028 RS	HJ 486028 2RS	IR 384828	24 100	50 900	1 300	1.51
							IR 404828				

† See pages XXX for inch series inner ring. Inner rings must be ordered separately



# Drawn Cup Clutch Bearings

## RC

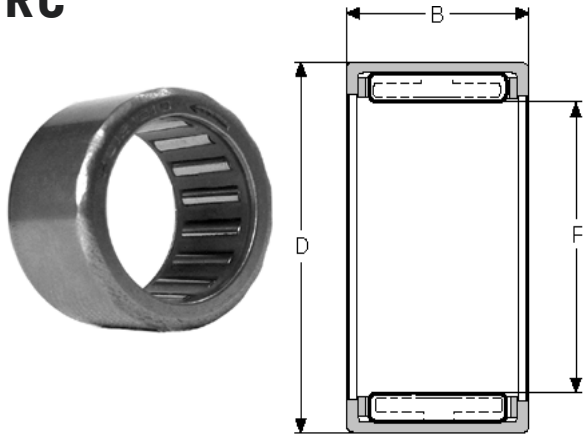

## RCB

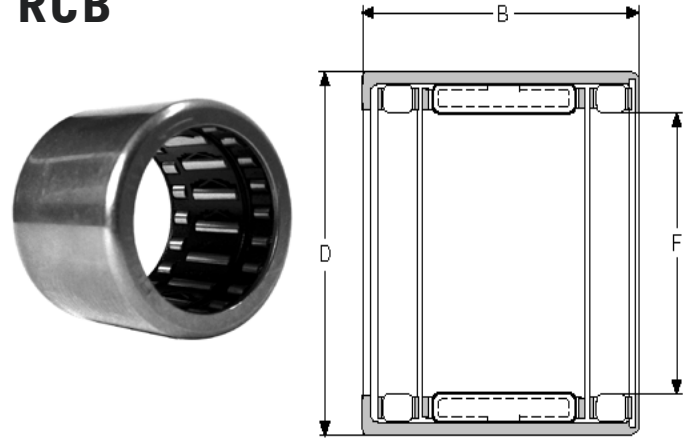

## RC

Unit No.		Shaft Diameter	Bore (inch)	Outer Diameter (inch)	Width (inch)	Torque Rating (in-lbf)	Minimum O.D. of Steel Housing for rated torque	Overrun Limiting Speed for Rotating Shaft	Suitable Drawn Cup Bearing	Weight
Stainless Spring	Integral Spring		F	D	B					
-	RC 02	1/8	0.125	0.281	0.250	2.86	0.44	34,000	-	0.002
-	RC 040708	1/4	0.250	0.438	0.500	17.9	0.62	20,000	J 45	0.008
RC 061008 FS	RC 061008	3/8	0.375	0.625	0.500	48	0.88	18,000	JH 68	0.017
RC 081208 FS	RC 081208	1/2	0.500	0.750	0.500	78	1.10	17,000	JH 87	0.020
RC 101410 FS	RC 101410	5/8	0.625	0.875	0.625	149	1.20	14,000	JH 1010	0.030
RC 121610 FS	RC 121610	3/4	0.750	1.000	0.625	206	1.40	12,000	J 126	0.034
RC 162110 FS	RC 162110	1	1.000	1.313	0.625	439	1.90	8,700	JH 1612	0.058

## RCB

Unit No.		Shaft Diameter	Bore (inch)	Outer Diameter (inch)	Width (inch)	Torque Rating (in-lbf)	Static Load Rating	Dynamic Load Rating	Overrun Limiting Speed for Rotating Shaft	Weight
Stainless Spring	Integral Spring		F	D	B					
RCB 061014 FS	RCB 061014	3/8	0.375	0.625	0.875	48.2	1,100	1,350	18,000	0.030
RCB 081214 FS	RCB 081214	1/2	0.500	0.750	0.875	78.3	1,460	1,600	17,000	0.036
RCB 101416 FS	RCB 101416	5/8	0.625	0.875	1.000	149.0	1,830	1,810	14,000	0.050
RCB 121616 FS	RCB 121616	3/4	0.750	1.000	1.000	206.0	2,200	2,000	12,000	0.057
RCB 162117 FS	RCB 162117	1	1.000	1.313	1.063	439.0	3,960	3,460	8,700	0.100



# Thrust Needle Bearing

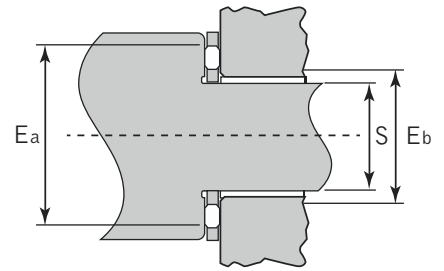
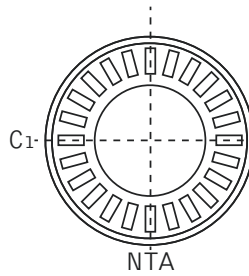
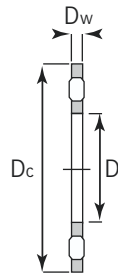

Minimum hardness of raceway must be 58 HRC

## NTA

Bearing Designation	Shaft Diameter	Dimensions Dc1 (inch)	Dc	Dw	Eb	Ea	Load Ratings Basic lbf		Limiting Speed Oil	Mass Approx. lbs
							Dynamic C	Static C0		
NTA 411	1/4	0.25	0.687	0.0781	0.34	0.58	1 150	2 420	26 000	0.003
NTA 512	5/16	0.312	0.75	0.0781	0.4	0.64	1 310	2 960	24 000	0.004
NTA 613	3/8	0.375	0.812	0.0781	0.46	0.71	1 360	3 220	22 000	0.004
NTA 815	1/2	0.5	0.937	0.0781	0.59	0.83	1 610	4 300	19 000	0.005
NTA 916	9/16	0.562	1	0.0781	0.65	0.89	1 730	4 840	18 000	0.006
NTA 1018	5/8	0.625	1.125	0.0781	0.71	1.02	2 200	6 830	15 000	0.007
NTA 1220	3/4	0.75	1.25	0.0781	0.84	1.14	2 450	8 200	14 000	0.009
NTA 1423	7/8	0.875	1.437	0.0781	0.96	1.33	3 020	11 200	12 000	0.011
NTA 1427	7/8	0.875	1.687	0.0781	1.02	1.57	4 150	17 600	9 800	0.017
NTA 1625	1	1	1.562	0.0781	1.09	1.45	3 110	12 100	11 000	0.013
NTA 1828	1-1/8	1.125	1.75	0.0781	1.21	1.64	3 750	16 000	6 900	0.019
NTA 2031	1-1/4	1.25	1.937	0.0781	1.34	1.82	4 530	21 000	8 600	0.021
NTA 2233	1-3/8	1.375	2.062	0.0781	1.46	1.95	4 800	23 200	8 000	0.023
NTA 2435	1-1/2	1.5	2.187	0.0781	1.59	2.07	5 220	26 500	7 600	0.025
NTA 2840	1-3/4	1.75	2.5	0.0781	1.84	2.32	5 690	30 900	6 800	0.031
NTA 3244	2	2	2.75	0.0781	2.09	2.57	5 400	29 800	6 100	0.033
NTA 3446	2-1/8	2.125	2.875	0.0781	2.22	2.7	5 490	30 900	5 800	0.036
NTA 3648	2-1/4	2.25	3	0.0781	2.34	2.82	5 570	32 000	5 600	0.038
NTA 3650	2-1/4	2.25	3.125	0.125	2.36	2.96	8 470	39 800	5 300	0.064
NTA 4052	2-1/2	2.5	3.25	0.0781	2.59	3.07	5 740	34 200	5 100	0.041
NTA 4458	2-3/4	2.75	3.625	0.125	2.86	3.46	10 700	57 500	4 600	0.082
NTA 4860	3	3	3.75	0.0781	3.09	3.57	6 060	38 700	4 400	0.048
NTA 5266	3-1/4	3.25	4.125	0.125	3.36	3.96	11 600	66 300	4 000	0.092
NTA 6074	3-3/4	3.75	4.625	0.125	3.86	4.46	12 600	77 400	3 500	0.11
NTA 6681	4-1/8	4.125	5.062	0.125	4.23	4.9	14 300	93 200	3 200	0.136



# Thrust Needle Bearing

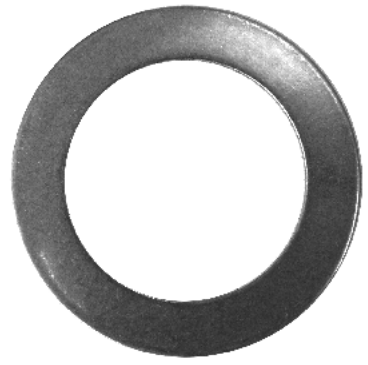

## Thrust Washers

Washer Designation	Matching Bearing	Shaft Diameter	Thrust Washer Dimensions				Piloting Dimensions Shaft Pilot Diameter		Diameter to Clear Washer O.D. min.	Mass Approx. (lbs)
			(inch) d	(inch) d1	min.	max.	min. inch	max. inch		
					h					
TRA 411	NTA 411	1/4	0.25	0.687	0.03	0.032	0.247	0.25	0.719	0.003
TRB 411	NTA 411		0.25	0.687	0.06	0.063	0.247	0.25	0.719	0.005
TRC 411	NTA 411		0.25	0.687	0.092	0.095	0.247	0.25	0.719	0.008
TRA 512	NTA 512	5/16	0.312	0.75	0.03	0.032	0.309	0.312	0.781	0.003
TRB 512	NTA 512		0.312	0.75	0.06	0.063	0.309	0.312	0.781	0.006
TRA 613	NTA 613	3/8	0.375	0.812	0.03	0.032	0.372	0.375	0.844	0.003
TRB 613	NTA 613		0.375	0.812	0.06	0.063	0.372	0.375	0.844	0.006
TRC 613	NTA 613		0.375	0.812	0.092	0.095	0.372	0.375	0.844	0.009
TRA 815	NTA 815	1/2	0.5	0.937	0.03	0.032	0.497	0.5	0.969	0.004
TRB 815	NTA 815		0.5	0.937	0.06	0.063	0.497	0.5	0.969	0.008
TRC 815	NTA 815		0.5	0.937	0.092	0.095	0.497	0.5	0.969	0.012
TRA 916	NTA 916	9/16	0.562	1	0.03	0.032	0.559	0.562	1.031	0.005
TRB 916	NTA 916		0.562	1	0.06	0.063	0.559	0.562	1.031	0.008
TRC 916	NTA 916		0.562	1	0.092	0.095	0.559	0.562	1.031	0.013
TRA 1018	NTA 1018	5/8	0.625	1.125	0.03	0.032	0.622	0.625	1.156	0.006
TRB 1018	NTA 1018		0.625	1.125	0.06	0.063	0.622	0.625	1.156	0.012
TRC 1018	NTA 1018		0.625	1.125	0.092	0.095	0.622	0.625	1.156	0.018
TRD 1018	NTA 1018		0.625	1.125	0.123	0.126	0.622	0.625	1.156	0.024
TRA 1220	NTA 1220	3/4	0.75	1.25	0.03	0.032	0.747	0.75	1.281	0.007
TRB 1220	NTA 1220		0.75	1.25	0.06	0.063	0.747	0.75	1.281	0.013
TRC 1220	NTA 1220		0.75	1.25	0.092	0.095	0.747	0.75	1.281	0.021
TRD 1220	NTA 1220		0.75	1.25	0.123	0.126	0.747	0.75	1.281	0.026
TRA 1423	NTA 1423	7/8	0.875	1.437	0.03	0.032	0.872	0.875	1.469	0.009
TRB 1423	NTA 1423		0.875	1.437	0.06	0.063	0.872	0.875	1.469	0.017
TRC 1423	NTA 1423		0.875	1.437	0.092	0.095	0.872	0.875	1.469	0.026
TRD 1423	NTA 1423		0.875	1.437	0.123	0.126	0.872	0.875	1.469	0.034
TRB 1427	NTC 1427		0.875	1.687	0.06	0.063	0.872	0.875	1.719	0.029
TRC 1427	NTC 1427		0.875	1.687	0.092	0.095	0.872	0.875	1.719	0.044
TRD 1427	NTC 1427		0.875	1.687	0.123	0.126	0.872	0.875	1.719	0.057
TRA 1625	NTA 1625	1	1	1.562	0.03	0.032	0.997	1	1.594	0.01
TRB 1625	NTA 1625		1	1.562	0.06	0.063	0.997	1	1.594	0.019
TRD 1625	NTA 1625		1	1.562	0.123	0.126	0.997	1	1.594	0.038
TRA 1828	NTA 1828	1-1/8	1.125	1.75	0.03	0.032	1.122	1.125	1.781	0.013
TRB 1828	NTA 1828		1.125	1.75	0.06	0.063	1.122	1.125	1.781	0.024
TRC 1828	NTA 1828		1.125	1.75	0.092	0.095	1.122	1.125	1.781	0.037
TRD 1828	NTA 1828		1.125	1.75	0.123	0.126	1.122	1.125	1.781	0.048
TRA 2031	NTA 2031	1-1/4	1.25	1.937	0.03	0.032	1.247	1.25	1.781	0.015
TRB 2031	NTA 2031		1.25	1.937	0.06	0.063	1.247	1.25	1.781	0.03
TRC 2031	NTA 2031		1.25	1.937	0.092	0.095	1.247	1.25	1.781	0.044
TRD 2031	NTA 2031		1.25	1.937	0.123	0.126	1.247	1.25	1.781	0.058

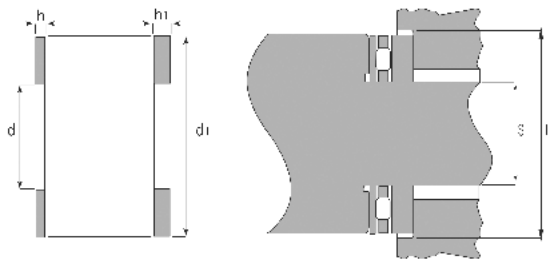

# Thrust Needle Bearing



## Thrust Washers

Washer Designation	Matching Bearing	Shaft Diameter	Thrust Washer Dimensions				Piloting Dimensions Shaft Pilot Diameter		Diameter to Clear Washer O.D. min.	Mass Approx. (lbs)	
			(inch) d	(inch) d1	h		min. inch	max. inch			S
					H						
TRA 2233	NTA 2233	1-3/8	1.375	2.062	0.03	0.032	1.372	1.375	2.094	0.016	
TRB 2233	NTA 2233		1.25	2.062	0.06	0.063	1.372	1.375	2.094	0.033	
TRC 2233	NTA 2233		1.25	2.062	0.092	0.095	1.372	1.375	2.094	0.040	
TRD 2233	NTA 2233		1.25	2.062	0.123	0.126	1.372	1.375	2.094	0.065	
TRA 2435	NTA 2435	1-1/2	1.5	2.187	0.03	0.032	1.497	1.5	2.219	0.017	
TRB 2435	NTA 2435		1.5	2.187	0.06	0.063	1.497	1.5	2.219	0.034	
TRC 2435	NTA 2435		1.5	2.187	0.092	0.095	1.497	1.5	2.219	0.050	
TRD 2435	NTA 2435		1.5	2.187	0.123	0.126	1.497	1.5	2.219	0.067	
TRA 2840	NTA 2840	1-3/4	1.75	2.5	0.03	0.032	1.747	1.75	2.531	0.021	
TRB 2840	NTA 2840		1.75	2.5	0.06	0.063	1.747	1.75	2.531	0.044	
TRC 2840	NTA 2840		1.75	2.5	0.092	0.095	1.747	1.75	2.531	0.063	
TRD 2840	NTA 2840		1.75	2.5	0.123	0.126	1.747	1.75	2.531	0.084	
TRA 3244	NTA 3244	2	2	2.75	0.03	0.032	1.997	2	2.781	0.024	
TRB 3244	NTA 3244		2	2.75	0.06	0.063	1.997	2	2.781	0.048	
TRC 3244	NTA 3244		2	2.75	0.092	0.095	1.997	2	2.781	0.072	
TRD 3244	NTA 3244		2	2.75	0.123	0.126	1.997	2	2.781	0.096	
TRA 3446	NTA 3446	2-1/8	2.125	2.875	0.06	0.063	2.122	2.125	2.906	0.052	
TRB 3446	NTA 3446		2.125	2.875	0.092	0.095	2.122	2.125	2.906	0.078	
TRD 3446	NTA 3446		2.125	2.875	0.123	0.126	2.122	2.125	2.906	0.103	
TRA 3648	NTA 3648	2-1/4	2.25	3	0.03	0.032	2.247	2.25	3.031	0.026	
TRB 3648	NTA 3648		2.25	3	0.06	0.063	2.247	2.25	3.031	0.048	
TRC 3648	NTA 3648		2.25	3	0.092	0.095	2.247	2.25	3.031	0.081	
TRD 3648	NTA 3648		2.25	3	0.123	0.126	2.247	2.25	3.031	0.105	
TRA 4052	NTA 4052	2-1/2	2.5	3.25	0.03	0.032	2.497	2.5	3.281	0.029	
TRB 4052	NTA 4052		2.5	3.25	0.06	0.063	2.497	2.5	3.281	0.059	
TRC 4052	NTA 4052		2.5	3.25	0.092	0.095	2.497	2.5	3.281	0.09	
TRD 4052	NTA 4052		2.5	3.25	0.123	0.126	2.497	2.5	3.281	0.119	
TRA 4458	NTA 4458	3-3/4	2.75	3.625	0.03	0.032	2.747	2.75	3.656	0.039	
TRB 4458	NTA 4458		2.75	3.625	0.06	0.063	2.747	2.75	3.656	0.077	
TRC 4458	NTA 4458		2.75	3.625	0.092	0.095	2.747	2.75	3.656	0.113	
TRD 5548	NTA 4458		2.75	3.625	0.123	0.126	2.747	2.75	3.656	0.152	
TRA 4860	NTA 4860	3	3	3.75	0.03	0.032	2.997	3	3.781	0.034	
TRB 4860	NTA 4860		3	3.75	0.06	0.063	2.997	3	3.781	0.07	
TRD 4860	NTA 4860		3	3.75	0.123	0.126	2.997	3	3.781	0.135	
TRA 5266	NTA 5266	3-1/4	3.25	4.125	0.03	0.032	3.247	3.25	4.156	0.044	
TRD 5266	NTA 5266		3.25	4.125	0.123	0.126	3.247	3.25	4.156	0.176	
TRA 6074	NTA 6074	3-3/4	3.75	4.625	0.03	0.032	3.747	3.75	4.656	0.05	
TRB 6074	NTA 6074		3.75	4.625	0.06	0.063	3.747	3.75	4.656	0.101	
TRC 6074	NTA 6074		3.75	4.625	0.092	0.095	3.747	3.75	4.656	0.152	
TRD 6074	NTA 6074		3.75	4.625	0.123	0.126	3.747	3.75	4.656	0.202	
TRA 6681	NTA 6681	4-1/8	4.125	5.062	0.03	0.032	4.122	4.125	5.094	0.059	
TRC 6681	NTA 6681		4.125	5.062	0.092	0.095	4.122	4.125	5.094	0.178	
TRD 6681	NTA 6681		4.125	5.062	0.123	0.126	4.122	4.125	5.094	0.24	

# Spherical Plain

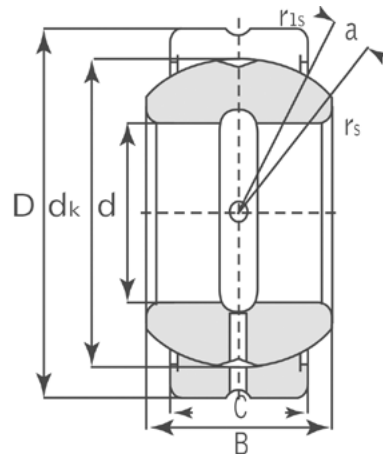

## GE ES / GE ES-2RS

Bearing Number		Dimensions (mm)								Load Ratings kN		Weight ~ kg
		d	D	B	C	dk	min rs	min r1s	a ~	Dynamic	Static	
GE4E		4	12	5	3	8	0.3	0.3	16	2	10	0.003
GE5E		5	14	6	4	10	0.3	0.3	13	3.4	17	0.005
GE6E		6	14	6	4	10	0.3	0.3	13	3.4	17	0.004
GE8E		8	16	8	5	13	0.3	0.3	15	5.5	27	0.008
GE10E		10	19	9	6	16	0.3	0.3	12	8.1	40	0.011
GE12E		12	22	10	7	18	0.3	0.3	10	10	53	0.015
GE15ES	GE15ES-2RS	15	26	12	9	22	0.3	0.3	8	16	84	0.027
GE17ES	GE17ES-2RS	17	30	14	10	25	0.3	0.3	10	21	106	0.041
GE20ES	GE20ES-2RS	20	35	16	12	29	0.3	0.3	9	30	146	0.066
GE25ES	GE25ES-2RS	25	42	20	16	35.5	0.6	0.6	7	48	240	0.119
GE30ES	GE30ES-2RS	30	47	22	18	40.7	0.6	0.6	6	62	310	0.153
GE35ES	GE35ES-2RS	35	55	25	20	47	0.6	1	6	79	399	0.233
GE40ES	GE40ES-2RS	40	62	28	22	53	0.6	1	7	99	495	0.306
GE45ES	GE45ES-2RS	45	68	32	25	60	0.6	1	7	127	637	0.427
GE50ES	GE50ES-2RS	50	75	35	28	66	0.6	1	6	156	780	0.546
GE55ES	GE55ES-2RS	55	85	40	32	74	0.6	1	7	200	1000	0.939
GE60ES	GE60ES-2RS	60	90	44	36	80	1	1	6	245	1220	1.04
GE70ES	GE70ES-2RS	70	105	49	40	92	1	1	6	313	1560	1.55
GE80ES	GE80ES-2RS	80	120	55	45	105	1	1	6	400	2000	2.31
GE90ES	GE90ES-2RS	90	130	60	50	115	1	1	5	488	2440	2.75
GE100ES	GE100ES-2RS	100	150	70	55	130	1	1	7	607	3030	4.45
GE110ES	GE110ES-2RS	110	160	70	55	140	1	1	6	654	3270	4.82
GE120ES	GE120ES-2RS	120	180	85	70	160	1	1	6	950	4750	8.05
GE140ES	GE140ES-2RS	140	210	90	70	180	1	1	7	1070	5350	11.02
GE160ES	GE160ES-2RS	160	230	105	80	200	1	1	8	1360	6800	14.01
GE180ES	GE180ES-2RS	180	260	105	80	225	1.1	1.1	6	1530	7650	18.65
GE200ES	GE200ES-2RS	200	290	130	100	250	1.1	1.1	7	2120	10600	28.03
GE220ES	GE220ES-2RS	220	320	135	100	275	1.1	1.1	8	2320	11600	35.51
GE240ES	GE240ES-2RS	240	340	140	100	300	1.1	1.1	8	2550	12700	39.91
GE260ES	GE260ES-2RS	260	370	150	110	325	1.1	1.1	7	3030	15190	51.54
GE280ES	GE280ES-2RS	280	400	155	120	350	1.1	1.1	6	3570	17850	65.06
GE300ES	GE300ES-2RS	300	430	165	120	375	1.1	1.1	7	3800	19100	78.07

# Spherical Plain

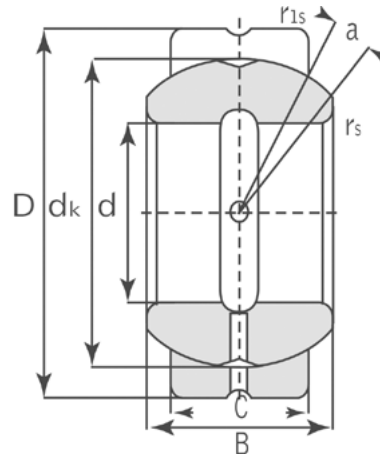

## GEG ES / GEG ES-2RS

Bearing Number		Dimensions (mm)								Load Ratings kN		Weight ~ kg
		d	D	B	C	dk	min rs	min r1s	a ~	Dynamic	Static	
GEG4E		4	14	7	4	10	0.3	0.3	20	3.4	17	0.005
GEG5E		5	16	9	5	13	0.3	0.3	21	5.5	27	0.008
GEG6E		6	16	9	5	13	0.3	0.3	21	5.5	27	0.006
GEG8E		8	19	11	6	16	0.3	0.3	21	8.1	40	0.014
GEG10E		10	22	12	7	18	0.3	0.3	18	10	53	0.021
GEG12E		12	26	15	9	22	0.3	0.3	18	16	84	0.033
GEG15ES	GEG15ES-2RS	15	30	16	10	25	0.3	0.3	16	21	106	0.049
GEG17ES	GEG17ES-2RS	17	35	20	12	29	0.3	0.3	19	30	146	0.083
GEG20ES	GEG20ES-2RS	20	42	25	16	35.5	0.3	0.6	17	48	240	0.153
GEG25ES	GEG25ES-2RS	25	47	28	18	40.7	0.6	0.6	17	62	310	0.203
GEG30ES	GEG30ES-2RS	30	55	32	20	47	0.6	1	17	79	399	0.304
GEG35ES	GEG35ES-2RS	35	62	35	22	53	0.6	1	16	99	495	0.408
GEG40ES	GEG40ES-2RS	40	68	40	25	60	0.6	1	17	127	637	0.542
GEG45ES	GEG45ES-2RS	45	75	43	28	66	0.6	1	15	156	780	0.713
GEG50ES	GEG50ES-2RS	50	90	56	36	80	0.6	1	17	245	1220	1.14
GEG60ES	GEG60ES-2RS	60	105	63	40	92	1	1	17	313	1560	2.05
GEG70ES	GEG70ES-2RS	70	120	70	45	105	1	1	16	400	2000	3.01
GEG80ES	GEG80ES-2RS	80	130	75	50	115	1	1	14	488	2440	3.64
GEG90ES	GEG90ES-2RS	90	150	85	55	130	1	1	15	607	3030	5.22
GEG100ES	GEG100ES-2RS	100	160	85	55	140	1	1	14	654	3270	6.05
GEG110ES	GEG110ES-2RS	110	180	100	70	160	1	1	12	950	4750	9.68
GEG120ES	GEG120ES-2RS	120	210	115	70	180	1	1	16	1070	5350	14.01
GEG140ES	GEG140ES-2RS	140	230	130	80	200	1	1	16	1360	6800	19.01
GEG160ES	GEG160ES-2RS	160	260	135	80	225	1.1	1.1	16	1530	7650	24.7
GEG180ES	GEG180ES-2RS	180	290	155	100	250	1.1	1.1	14	2120	10600	35.9
GEG200ES	GEG200ES-2RS	200	320	165	100	275	1.1	1.1	15	2320	11600	45.28
GEG220ES	GEG220ES-2RS	220	340	175	100	300	1.1	1.1	16	2550	12700	51.12
GEG240ES	GEG240ES-2RS	240	370	190	110	325	1.1	1.1	15	3030	15190	65.12
GEG260ES	GEG260ES-2RS	260	400	205	120	350	1.1	1.1	15	3570	17850	82.44
GEG280ES	GEG280ES-2RS	280	430	210	120	375	1.1	1.1	15	3800	19100	97.21

# Spherical Plain

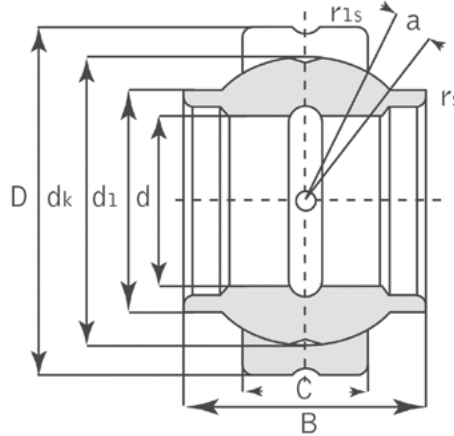

## GEEW ES

Bearing Number	Dimensions (mm)									Load Ratings kN		Weight ~kg
	d	D	B	C	max d1	dk	min rs	min r1s	a' ~	Dynamic	Static	
GEEW12ES*	12	22	12	7	15.5	18	0.3	0.3	4	10	53	0.022
GEEW15ES	15	26	15	9	18.5	22	0.3	0.3	5	16	84	0.031
GEEW16ES	16	28	16	9	20	23	0.3	0.3	4	17	85	0.035
GEEW17ES	17	30	17	10	21	25	0.3	0.3	7	21	106	0.044
GEEW20ES	20	35	20	12	25	29	0.3	0.3	4	30	146	0.071
GEEW25ES	25	42	25	16	30.5	35.5	0.6	0.6	4	48	240	0.131
GEEW30ES	30	47	30	18	34	40.7	0.6	0.6	4	62	310	0.168
GEEW32ES	32	52	32	18	37	43	0.6	1	4	65	328	0.182
GEEW35ES	35	55	35	20	40	47	0.6	1	4	79	399	0.253
GEEW40ES	40	62	40	22	46	53	0.6	1	4	99	495	0.338
GEEW45ES	45	68	45	25	52	60	0.6	1	4	127	637	0.481
GEEW50ES	50	75	50	28	57	66	0.6	1	4	156	780	0.558
GEEW60ES	60	90	60	36	68	80	1	1	4	245	1220	1.15
GEEW63ES	63	95	63	36	71.5	83	1	1	4	253	1260	1.25
GEEW70ES	70	105	70	40	78	92	1	1	4	313	1560	1.71
GEEW80ES	80	120	80	45	91	105	1	1	4	400	2000	2.39
GEEW90ES	90	130	90	50	99	115	1	1	4	488	2440	3.21
GEEW100ES	100	150	100	55	113	130	1	1	4	607	3030	4.79
GEEW110ES	110	160	110	55	124	140	1	1	4	654	3270	5.78
GEEW125ES	125	180	125	70	138	160	1	1	4	950	4750	8.49
GEEW160ES	160	230	160	80	177	200	1	1	4	1360	6800	16.5
GEEW200ES	200	290	200	100	221	250	1.1	1.1	4	2120	10600	32.1
GEEW250ES	250	400	250	120	317	350	1.1	1.1	4	3750	17800	99.1
GEEW320ES	320	520	320	160	405	450	1.1	1.1	4	6200	30500	225

\* A lubrication groove and holes in the outer ring only.  
We can supply spherical plain bearing with two seals for bore diameter  $d \geq 15$ mm.

# Spherical Plain

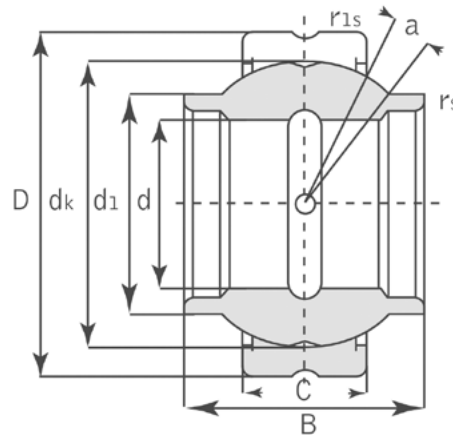

## GEEM ES-2RS

Bearing Number	Dimensions (mm)									Load Ratings kN		Weight ~kg
	d	D	B	C	max d1	dk	min rs	min r1s	a <sup>°</sup> ~	Dynamic	Static	
GEEM20ES-2RS	20	35	24	12	24	29	0.3	0.3	6	30	146	0.073
GEEM25ES-2RS	25	42	29	16	29	35.5	0.3	0.6	4	48	240	0.13
GEEM30ES-2RS	30	47	30	18	34	40.7	0.3	0.6	4	62	310	0.17
GEEM35ES-2RS	35	55	35	20	40	47	0.6	1	4	79	399	0.25
GEEM40ES-2RS	40	62	38	22	45	53	0.6	1	4	99	495	0.35
GEEM45ES-2RS	45	68	40	25	52	60	0.6	1	4	127	637	0.49
GEEM50ES-2RS	50	75	43	28	57	66	0.6	1	4	156	780	0.6
GEEM60ES-2RS	60	90	54	36	68	80	0.6	1	3	245	1220	1.15
GEEM70ES-2RS	70	105	65	40	78	92	0.6	1	4	313	1560	1.65
GEEM80ES-2RS	80	120	74	45	90	105	0.6	1	4	400	2000	2.5

# Spherical Plain

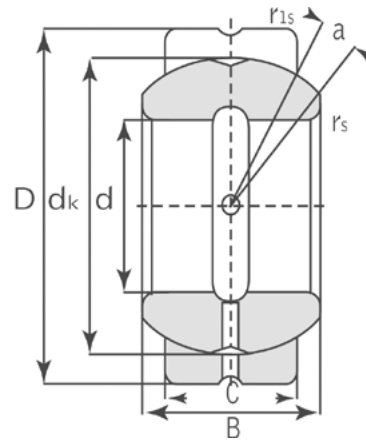

## GEZ ES / GEZ ES-2RS

Bearing Number		Dimensions (inch / mm)								Load Ratings kN		Weight ~ kg
		d	D	B	C	dk	min rs	min r1s	a	Dynamic	Static	
GEZ12ES		<b>0.5</b> 12.7	<b>0.875</b> 22.22	<b>0.437</b> 11.1	<b>0.375</b> 9.52	<b>0.707</b> 18	<b>0.006</b> 0.15	<b>0.024</b> 0.6	6	13	41	0.022
GEZ15ES		<b>0.625</b> 15.87	<b>1.0625</b> 26.99	<b>0.547</b> 13.89	<b>0.469</b> 11.91	<b>0.904</b> 23	<b>0.006</b> 0.15	<b>0.024</b> 0.6	6	22	65	0.036
GEZ19ES	GEZ19ES-2RS	<b>0.75</b> 19.050	<b>1.25</b> 31.750	<b>0.656</b> 16.662	<b>0.562</b> 14.275	<b>1.081</b> 27.5	<b>0.012</b> 0.3	<b>0.024</b> 0.6	6	31	95	0.053
GEZ22ES	GEZ22ES-2RS	<b>0.875</b> 22.225	<b>1.4375</b> 36.513	<b>0.756</b> 19.431	<b>0.656</b> 16.662	<b>1.258</b> 32	<b>0.012</b> 0.3	<b>0.024</b> 0.6	6	42	127	0.085
GEZ25ES	GEZ25ES-2RS	<b>1</b> 25.400	<b>1.625</b> 41.275	<b>0.875</b> 22.225	<b>0.75</b> 19.050	<b>1.437</b> 36.5	<b>0.012</b> 0.3	<b>0.024</b> 0.6	6	56	166	0.121
GEZ31ES	GEZ31ES-2RS	<b>1.25</b> 31.750	<b>2</b> 50.800	<b>1.093</b> 27.762	<b>0.937</b> 23.800	<b>1.788</b> 45.5	<b>0.024</b> 0.6	<b>0.024</b> 0.6	6	86	260	0.23
GEZ34ES	GEZ34ES-2RS	<b>1.375</b> 34.925	<b>2.1875</b> 55.563	<b>1.187</b> 30.150	<b>1.031</b> 26.187	<b>1.926</b> 49	<b>0.024</b> 0.6	<b>0.04</b> 1	6	102	310	0.35
GEZ38ES	GEZ38ES-2RS	<b>1.5</b> 38.100	<b>2.4375</b> 61.913	<b>1.312</b> 33.325	<b>1.125</b> 28.575	<b>2.154</b> 54.7	<b>0.024</b> 0.6	<b>0.04</b> 1	6	125	375	0.42
GEZ44ES	GEZ44ES-2RS	<b>1.75</b> 44.450	<b>2.8125</b> 71.438	<b>1.531</b> 38.887	<b>1.312</b> 33.325	<b>2.511</b> 63.9	<b>0.024</b> 0.6	<b>0.04</b> 1	6	170	510	0.64
GEZ50ES	GEZ50ES-2RS	<b>2</b> 50.800	<b>3.1875</b> 80.963	<b>1.75</b> 44.450	<b>1.5</b> 38.100	<b>2.869</b> 73	<b>0.024</b> 0.6	<b>0.04</b> 1	6	224	670	0.93
GEZ57ES	GEZ57ES-2RS	<b>2.25</b> 57.150	<b>3.5625</b> 90.488	<b>1.969</b> 50.013	<b>1.687</b> 42.850	<b>3.223</b> 82	<b>0.024</b> 0.6	<b>0.04</b> 1	6	280	850	1.3
GEZ63ES	GEZ63ES-2RS	<b>2.5</b> 63.500	<b>3.9375</b> 100.013	<b>2.187</b> 55.550	<b>1.875</b> 47.625	<b>3.616</b> 92	<b>0.04</b> 1	<b>0.04</b> 1	6	355	1060	1.85



# Spherical Plain

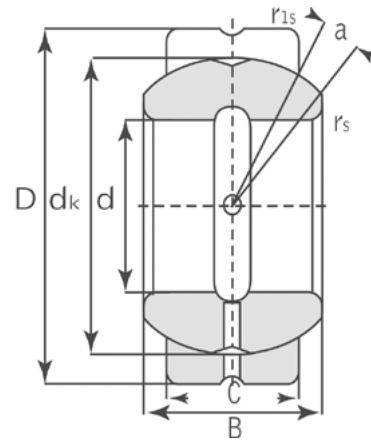

## GEZ ES / GEZ ES-2RS

Bearing Number		Dimensions (inch / mm)								Load Ratings kN		Weight ~ kg
		d	D	B	C	dk	min rs	min r1s	a ~	Dynamic	Static	
GEZ69ES	GEZ69ES-2RS	<b>2.75</b> 69.850	<b>4.375</b> 111.125	<b>2.406</b> 61.112	<b>2.062</b> 52.375	<b>3.937</b> 100	<b>0.04</b> 1	<b>0.04</b> 1	6	415	1250	2.4
GEZ76ES	GEZ76ES-2RS	<b>3</b> 76.200	<b>4.75</b> 120.650	<b>2.625</b> 66.675	<b>2.25</b> 57.150	<b>4.303</b> 109.5	<b>0.04</b> 1	<b>0.04</b> 1	6	500	1500	3.1
GEZ82ES	GEZ82ES-2RS	<b>3.25</b> 82.550	<b>5.125</b> 130.175	<b>2.844</b> 72.238	<b>2.437</b> 61.900	<b>4.685</b> 119	<b>0.04</b> 1	<b>0.04</b> 1	6	585	1760	3.8
GEZ88ES	GEZ88ES-2RS	<b>3.5</b> 88.900	<b>5.5</b> 139.700	<b>3.062</b> 77.775	<b>2.625</b> 66.675	<b>5.04</b> 128	<b>0.04</b> 1	<b>0.04</b> 1	6	680	2040	4.8
GEZ95ES	GEZ95ES-2RS	<b>3.75</b> 95.250	<b>5.875</b> 149.225	<b>3.281</b> 83.337	<b>2.812</b> 71.425	<b>5.393</b> 137	<b>0.04</b> 1	<b>0.04</b> 1	6	780	2360	5.8
GEZ101ES	GEZ101ES-2RS	<b>4</b> 101.600	<b>6.25</b> 158.750	<b>3.5</b> 88.900	<b>3</b> 76.200	<b>5.748</b> 146	<b>0.04</b> 1	<b>0.04</b> 1	6	900	2650	7
GEZ107ES	GEZ107ES-2RS	<b>4.25</b> 107.950	<b>6.625</b> 168.275	<b>3.719</b> 94.463	<b>3.187</b> 80.950	<b>6.102</b> 155	<b>0.04</b> 1	<b>0.04</b> 1	6	1000	3000	8.41
GEZ114ES	GEZ114ES-2RS	<b>4.5</b> 114.300	<b>7</b> 177.800	<b>3.937</b> 100.013	<b>3.375</b> 85.725	<b>6.476</b> 164.5	<b>0.04</b> 1	<b>0.04</b> 1	6	1120	3400	9.8
GEZ120ES	GEZ120ES-2RS	<b>4.75</b> 120.650	<b>7.375</b> 187.325	<b>4.156</b> 105.562	<b>3.562</b> 90.475	<b>6.83</b> 173.5	<b>0.04</b> 1	<b>0.04</b> 1	6	1250	3750	11.5
GEZ127ES	GEZ127ES-2RS	<b>5</b> 127.000	<b>7.75</b> 196.850	<b>4.375</b> 111.125	<b>3.75</b> 95.250	<b>7.204</b> 183	<b>0.04</b> 1	<b>0.04</b> 1	6	1400	4150	13.5
GEZ152ES	GEZ152ES-2RS	<b>6</b> 152.400	<b>8.75</b> 222.250	<b>4.75</b> 120.65	<b>4.125</b> 104.775	<b>8.15</b> 207	<b>0.04</b> 1	<b>0.04</b> 1	5	1730	5200	17.5

# Spherical Plain

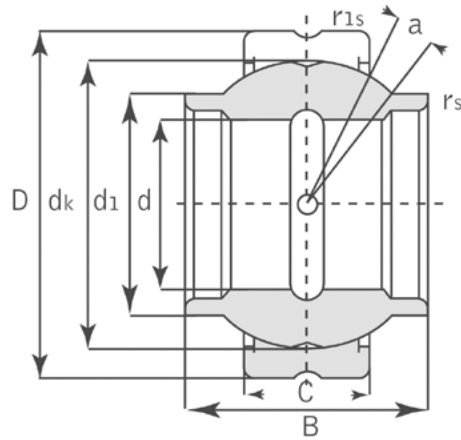

## GEWZ ES / GEWZ ES-2RS

Bearing Number		Dimensions (inch / mm)									Load Ratings kN		Weight ~kg
		d	D	B	C	max d1	dk	min rs	min r1s	a ~	Dynamic	Static	
GEWZ 12 ES		<b>0.5</b> 12.7	<b>0.875</b> 22.225	<b>0.75</b> 19.05	<b>0.375</b> 9.525	<b>0.625</b> 15.875	<b>0.719</b> 18	<b>0.006</b> 0.15	<b>0.024</b> 0.6	5	13	41	0.024
GEWZ15ES		<b>0.625</b> 15.875	<b>1.0625</b> 26.988	<b>0.937</b> 23.8	<b>0.469</b> 11.913	<b>0.78</b> 19.812	<b>0.899</b> 23	<b>0.006</b> 0.15	<b>0.024</b> 0.6	5	22	65	0.038
GEWZ19ES	GEWZ19ES-2RS	<b>0.75</b> 19.05	<b>1.25</b> 31.75	<b>1.125</b> 28.575	<b>0.562</b> 14.275	<b>0.92</b> 23.368	<b>1.08</b> 27.5	<b>0.012</b> 0.3	<b>0.024</b> 0.6	5	31	95	0.064
GEWZ22ES	GEWZ22ES-2RS	<b>0.875</b> 22.225	<b>1.4375</b> 36.513	<b>1.312</b> 33.325	<b>0.656</b> 16.662	<b>1.07</b> 27.178	<b>1.258</b> 32	<b>0.012</b> 0.3	<b>0.024</b> 0.6	5	42	127	0.098
GEWZ25ES	GEWZ25ES-2RS	<b>1</b> 25.4	<b>1.625</b> 41.275	<b>1.5</b> 38.1	<b>0.75</b> 19.05	<b>1.22</b> 30.988	<b>1.437</b> 36.5	<b>0.012</b> 0.3	<b>0.024</b> 0.6	5	56	166	0.142
GEWZ31ES	GEWZ31ES-2RS	<b>1.25</b> 31.75	<b>2</b> 50.8	<b>1.875</b> 47.625	<b>0.937</b> 23.8	<b>1.525</b> 38.735	<b>1.795</b> 45.5	<b>0.024</b> 0.6	<b>0.024</b> 0.6	5	86	260	0.271
GEWZ34ES	GEWZ34ES-2RS	<b>1.375</b> 34.925	<b>2.1875</b> 55.563	<b>2.062</b> 52.375	<b>1.031</b> 26.187	<b>1.67</b> 42.418	<b>1.937</b> 49	<b>0.024</b> 0.6	<b>0.04</b> 1	5	102	310	0.373
GEWZ38ES	GEWZ38ES-2RS	<b>1.5</b> 38.1	<b>2.4375</b> 61.913	<b>2.25</b> 57.15	<b>1.125</b> 28.575	<b>1.85</b> 46.99	<b>2.155</b> 54.7	<b>0.024</b> 0.6	<b>0.04</b> 1	5	125	375	0.494
GEWZ44ES	GEWZ44ES-2RS	<b>1.75</b> 44.45	<b>2.8125</b> 71.438	<b>2.625</b> 66.675	<b>1.312</b> 33.325	<b>2.165</b> 54.991	<b>2.515</b> 63.9	<b>0.024</b> 0.6	<b>0.04</b> 1	5	170	510	0.762
GEWZ50ES	GEWZ50ES-2RS	<b>2</b> 50.8	<b>3.1875</b> 80.963	<b>3</b> 76.2	<b>1.5</b> 38.1	<b>2.46</b> 62.484	<b>2.875</b> 73	<b>0.024</b> 0.6	<b>0.04</b> 1	5	224	670	1.11
GEWZ57ES	GEWZ57ES-2RS	<b>2.25</b> 57.15	<b>3.5625</b> 90.488	<b>3.375</b> 85.725	<b>1.687</b> 42.85	<b>2.76</b> 70.104	<b>3.235</b> 82	<b>0.024</b> 0.6	<b>0.04</b> 1	5	280	850	1.57
GEWZ63ES	GEWZ63ES-2RS	<b>2.5</b> 63.5	<b>3.9375</b> 100.013	<b>3.75</b> 95.25	<b>1.875</b> 47.625	<b>3.06</b> 77.724	<b>3.59</b> 92	<b>0.04</b> 1	<b>0.04</b> 1	5	355	1060	2.15
GEWZ69ES	GEWZ69ES-2RS	<b>2.75</b> 69.85	<b>4.375</b> 111.125	<b>4.125</b> 104.775	<b>2.062</b> 52.375	<b>3.38</b> 85.852	<b>3.95</b> 100	<b>0.04</b> 1	<b>0.04</b> 1	5	415	1250	2.9
GEWZ76ES	GEWZ76ES-2RS	<b>3</b> 76.2	<b>4.75</b> 120.65	<b>4.5</b> 114.3	<b>2.25</b> 57.15	<b>3.675</b> 93.345	<b>4.312</b> 109.5	<b>0.04</b> 1	<b>0.04</b> 1	5	500	1500	3.59
GEWZ82ES	GEWZ82ES-2RS	<b>3.25</b> 82.55	<b>5.125</b> 130.175	<b>4.875</b> 123.825	<b>2.437</b> 61.9	<b>3.985</b> 101.219	<b>4.675</b> 119	<b>0.04</b> 1	<b>0.04</b> 1	5	585	1760	4.69
GEWZ88ES	GEWZ88ES-2RS	<b>3.5</b> 88.9	<b>5.5</b> 139.7	<b>5.25</b> 133.35	<b>2.625</b> 66.675	<b>4.3</b> 109.22	<b>5.04</b> 128	<b>0.04</b> 1	<b>0.04</b> 1	5	680	2040	5.86
GEWZ95ES	GEWZ95ES-2RS	<b>3.75</b> 95.25	<b>5.875</b> 149.225	<b>5.625</b> 142.875	<b>2.812</b> 71.425	<b>4.59</b> 116.586	<b>5.39</b> 137	<b>0.04</b> 1	<b>0.04</b> 1	5	780	2360	7.11
GEWZ101ES	GEWZ101ES-2RS	<b>4</b> 101.6	<b>6.25</b> 158.75	<b>6</b> 152.4	<b>3</b> 76.2	<b>4.905</b> 124.587	<b>5.75</b> 146	<b>0.04</b> 1	<b>0.04</b> 1	5	900	2650	8.56
GEWZ114ES	GEWZ114ES-2RS	<b>4.5</b> 114.3	<b>7</b> 177.8	<b>6.75</b> 171.45	<b>3.375</b> 85.725	<b>5.525</b> 140.335	<b>6.475</b> 164.5	<b>0.04</b> 1	<b>0.04</b> 1	5	1120	3400	12.24
GEWZ127ES	GEWZ127ES-2RS	<b>5</b> 127	<b>7.75</b> 196.85	<b>7.5</b> 190.5	<b>3.75</b> 95.25	<b>6.13</b> 155.705	<b>7.19</b> 183	<b>0.04</b> 1	<b>0.04</b> 1	5	1400	4150	16.63
GEWZ152ES	GEWZ152ES-2RS	<b>6</b> 152.4	<b>8.75</b> 222.25	<b>8.25</b> 209.55	<b>4.125</b> 104.775	<b>7.02</b> 178.308	<b>8.156</b> 207	<b>0.04</b> 1	<b>0.04</b> 1	5	1730	5200	20.7

# Spherical Plain

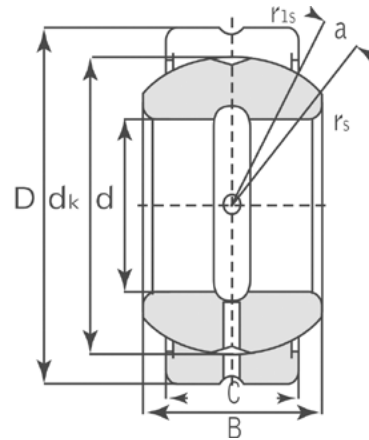

## GEGZ ES / GEGZ ES-2RS

Bearing Number		Dimensions (inch / mm)								Load Ratings kN		Weight ~kg
		d	D	B	C	dk	min rs	min r1s	a ~	Dynamic	Static	
GEGZ31ES	GEGZ31ES-2RS	<b>1.25</b> 31.75	<b>2.4375</b> 61.913	<b>1.39</b> 35.306	<b>1.125</b> 28.575	<b>2.155</b> 54.7	<b>0.024</b> 0.6	<b>0.04</b> 1	15	125	375	0.454
GEGZ38ES	GEGZ38ES-2RS	<b>1.5</b> 38.1	<b>2.8125</b> 71.438	<b>1.58</b> 40.132	<b>1.312</b> 33.325	<b>2.515</b> 63.9	<b>0.024</b> 0.6	<b>0.04</b> 1	14	170	510	0.726
GEGZ44ES	GEGZ44ES-2RS	<b>1.75</b> 44.45	<b>3.1875</b> 80.963	<b>1.82</b> 46.228	<b>1.5</b> 38.1	<b>2.875</b> 73	<b>0.024</b> 0.6	<b>0.04</b> 1	14	224	670	1.14
GEGZ50ES	GEGZ50ES-2RS	<b>2</b> 50.8	<b>3.5625</b> 90.488	<b>2.07</b> 52.578	<b>1.687</b> 42.85	<b>3.235</b> 82	<b>0.024</b> 0.6	<b>0.04</b> 1	14	280	850	1.68
GEGZ57ES	GEGZ57ES-2RS	<b>2.25</b> 57.15	<b>3.9375</b> 100.013	<b>2.318</b> 58.877	<b>1.875</b> 47.625	<b>3.59</b> 92	<b>0.024</b> 0.6	<b>0.04</b> 1	14	355	1060	2.01
GEGZ63ES	GEGZ63ES-2RS	<b>2.5</b> 63.5	<b>4.375</b> 111.125	<b>2.545</b> 64.643	<b>2.062</b> 52.375	<b>3.95</b> 100	<b>0.04</b> 1	<b>0.04</b> 1	14	415	1250	2.95
GEGZ69ES	GEGZ69ES-2RS	<b>2.75</b> 69.85	<b>4.75</b> 120.65	<b>2.79</b> 70.866	<b>2.25</b> 57.15	<b>4.312</b> 109.5	<b>0.04</b> 1	<b>0.04</b> 1	14	500	1500	3.63
GEGZ76ES	GEGZ76ES-2RS	<b>3</b> 76.2	<b>5.125</b> 130.175	<b>3.022</b> 76.759	<b>2.437</b> 61.9	<b>4.675</b> 119	<b>0.04</b> 1	<b>0.04</b> 1	14	585	1760	4.36
GEGZ82ES	GEGZ82ES-2RS	<b>3.25</b> 82.55	<b>5.5</b> 139.7	<b>3.265</b> 82.931	<b>2.625</b> 66.675	<b>5.04</b> 128	<b>0.04</b> 1	<b>0.04</b> 1	14	680	2040	5.31
GEGZ88ES	GEGZ88ES-2RS	<b>3.5</b> 88.9	<b>5.875</b> 149.225	<b>3.56</b> 90.424	<b>2.812</b> 71.425	<b>5.39</b> 137	<b>0.04</b> 1	<b>0.04</b> 1	14	780	2360	6.81
GEGZ95ES	GEGZ95ES-2RS	<b>3.75</b> 95.25	<b>6.25</b> 158.75	<b>3.738</b> 94.945	<b>3</b> 76.2	<b>5.75</b> 146	<b>0.04</b> 1	<b>0.04</b> 1	14	900	2650	8.85
GEGZ101ES	GEGZ101ES-2RS	<b>4</b> 101.6	<b>7</b> 177.8	<b>4.225</b> 107.315	<b>3.375</b> 85.725	<b>6.475</b> 164.5	<b>0.04</b> 1	<b>0.04</b> 1	10	1120	3400	10.2
GEGZ114ES	GEGZ114ES-2RS	<b>4.5</b> 114.3	<b>7.75</b> 196.85	<b>4.69</b> 119.126	<b>3.75</b> 95.25	<b>7.19</b> 183	<b>0.04</b> 1	<b>0.04</b> 1	10	1400	4150	13.6
GEGZ139ES	GEGZ139ES-2RS	<b>5.5</b> 139.7	<b>8.75</b> 222.25	<b>4.95</b> 125.73	<b>4.125</b> 104.775	<b>8.156</b> 207	<b>0.04</b> 1	<b>0.04</b> 1	9	1730	5200	20.4

# Spherical Plain

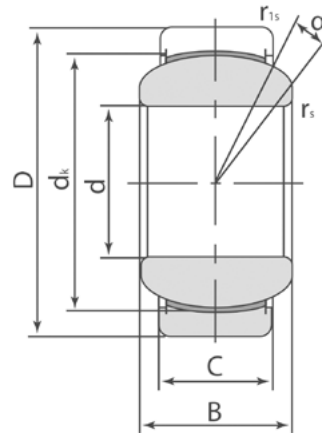

## GE & GEG..C

Bearing Number	Dimensions (mm)								Load Ratings kN		Weight ~kg
	d	D	B	C	dk	min rs	min r1s	a° ~	Dynamic	Static	
GE4C	4	12	5	3	8	0.3	0.3	16	2.1	5.4	0.003
GE5C	5	14	6	4	10	0.3	0.3	13	3.6	9.1	0.005
GE6C	6	14	6	4	10	0.3	0.3	13	3.6	9.1	0.004
GE8C	8	16	8	5	13	0.3	0.3	15	5.8	14	0.008
GE10C	10	19	9	6	16	0.3	0.3	12	8.6	21	0.011
GE12C	12	22	10	7	18	0.3	0.3	10	11	28	0.015
GE15C	15	26	12	9	22	0.3	0.3	8	18	45	0.027
GE17C	17	30	14	10	25	0.3	0.3	10	22	56	0.041
GE20C	20	35	16	12	29	0.3	0.3	9	31	78	0.066
GE25C	25	42	20	16	35.5	0.6	0.6	7	51	127	0.119
GE30C	30	47	22	18	40.7	0.6	0.6	6	65	166	0.163
GEG4C	4	14	7	4	10	0.3	0.3	20	3.6	9.1	0.005
GEG5C	5	16	9	5	13	0.3	0.3	21	5.8	14	0.008
GEG6C	6	16	9	5	13	0.3	0.3	21	5.8	14	0.006
GEG8C	8	19	11	6	16	0.3	0.3	21	8.6	21	0.014
GEG10C	10	22	12	7	18	0.3	0.3	18	11	28	0.021
GEG12C	12	26	15	9	22	0.3	0.3	18	18	45	0.033
GEG15C	15	30	16	10	25	0.3	0.3	16	22	56	0.049
GEG17C	17	35	20	12	29	0.3	0.3	19	31	78	0.083
GEG20C	20	42	25	16	35.5	0.3	0.3	17	51	127	0.153
GEG25C	25	47	28	18	40.7	0.6	0.6	17	65	166	0.203
GEG30C	30	55	32	20	47	0.6	0.6	17	83	212	0.304

# Spherical Plain

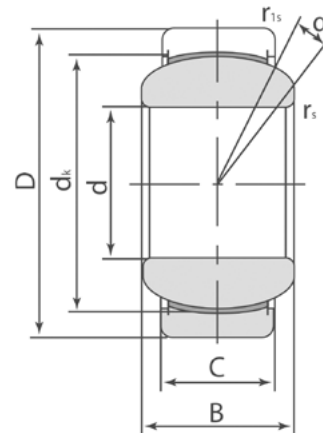

## GE ET/2RS - GE XT/2RS

Bearing Number		Dimensions (mm)								Load Ratings kN		Weight ~kg
		d	D	B	C	dk	min rs	min r1s	a ~	Dynamic	Static	
GE15ET	GE 15 ET 2RS	15	26	12	9	22	0.3	0.3	8	25	50	0.027
GE17ET	GE 17 ET 2RS	17	30	14	10	25	0.3	0.3	10	32	64	0.041
GE20ET	GE 20 ET 2RS	20	35	16	12	29	0.3	0.3	9	45	90	0.066
GE25ET	GE 25 ET 2RS	25	42	20	16	35.5	0.6	0.6	7	85	170	0.119
GE30ET	GE 30 ET 2RS	30	47	22	18	40.7	0.6	0.6	6	110	220	0.153
GE35ET	GE 35 ET 2RS	35	55	25	20	47	0.6	1	6	140	280	0.233
GE40ET	GE 40 ET 2RS	40	62	28	22	53	0.6	1	7	175	350	0.306
GE45ET	GE 45 ET 2RS	45	68	32	25	60	0.6	1	7	225	450	0.427
GE50ET	GE 50 ET 2RS	50	75	35	28	66	0.6	1	6	275	550	0.546
GE55ET	GE 55 ET 2RS	55	85	40	32	74	0.6	1	7	355	710	0.939
GE60ET	GE 60 ET 2RS	60	90	44	36	80	1	1	6	430	860	1.04
GE70ET	GE 70 ET 2RS	70	105	49	40	92	1	1	6	550	1100	1.55
GE80ET	GE 80 ET 2RS	80	120	55	45	105	1	1	6	705	1410	2.31
GE90ET	GE 90 ET 2RS	90	130	60	50	115	1	1	5	860	1720	2.75
GE100ET	GE 100 ET 2RS	100	150	70	55	130	1	1	7	1070	2140	4.45
GE110ET	GE 110 ET 2RS	110	160	70	55	140	1	1	6	1150	2300	4.82
GE120ET	GE 120 ET 2RS	120	180	85	70	160	1	1	6	1680	3360	8.05
GE140XT	GE 140 XT 2RS	140	210	90	70	180	1	1	7	1890	3780	11.02
GE160XT	GE 160 XT 2RS	160	230	105	80	200	1	1	8	2400	4800	14.01
GE180XT	GE 180 XT 2RS	180	260	105	80	225	1.1	1.1	6	2700	5400	18.65
GE200XT	GE 200 XT 2RS	200	290	130	100	250	1.1	1.1	7	3750	7500	28.03
GE220XT	GE 220 XT 2RS	220	320	135	100	275	1.1	1.1	8	4120	8240	35.51
GE240XT	GE 240 XT 2RS	220	320	135	100	275	1.1	1.1	8	4120	8240	35.51
GE260XT	GE 260 XT 2RS	260	370	150	110	325	1.1	1.1	7	5360	10720	51.54
GE280XT	GE 280 XT 2RS	280	400	155	120	350	1.1	1.1	6	6300	12600	65.06
GE300XT	GE 300 XT 2RS	300	430	165	120	375	1.1	1.1	7	6750	13500	78.07

GE... ET are made of carbon chromium steel, fractured, hardened and phosphated, with a sliding surface of PTFE fabric. The inner rings are made of carbon chromium steel and hardened. The sliding surface is treated with chromium plating. The 2RS design has seals at both sides.

# Spherical Plain

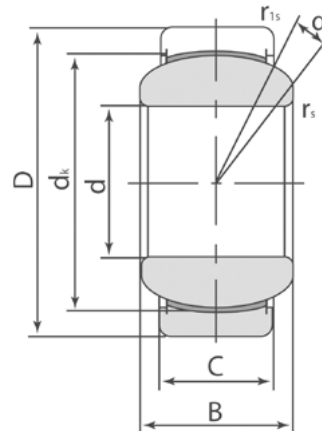

## GEZ ET-2RS

Bearing Number	Dimensions (inch / mm)								Load Ratings kN		Weight ~kg
	d	D	B	C	dk	min rs	min r1s	a° ~	Dynamic	Static	
GEZ19ET-2RS	0.75 / 19.05	1.25 / 31.75	0.656 / 16.662	0.562 / 14.275	1.081 / 27.5	0.012 / 0.3	0.024 / 0.6	6	50	100	0.053
GEZ22ET-2RS	0.875 / 22.225	1.4375 / 36.513	0.756 / 19.431	0.656 / 16.662	1.258 / 32	0.012 / 0.3	0.024 / 0.6	6	69	138	0.085
GEZ25ET-2RS	1 / 25.4	1.625 / 41.275	0.875 / 22.225	0.75 / 19.05	1.437 / 36.5	0.012 / 0.3	0.024 / 0.6	6	104	208	0.121
GEZ31ET-2RS	1.25 / 31.75	2 / 50.8	1.093 / 27.762	0.937 / 23.8	1.788 / 45.5	0.024 / 0.6	0.024 / 0.6	6	160	320	0.23
GEZ34ET-2RS	1.375 / 34.925	2.1875 / 55.563	1.187 / 30.15	1.031 / 26.187	1.926 / 49	0.024 / 0.6	0.04 / 1	6	190	380	0.35
GEZ38ET-2RS	1.5 / 38.1	2.4375 / 61.913	1.312 / 33.325	1.125 / 28.575	2.154 / 54.7	0.024 / 0.6	0.04 / 1	6	235	470	0.42
GEZ44ET-2RS	1.75 / 44.45	2.8125 / 71.438	1.531 / 38.887	1.312 / 33.325	2.511 / 63.9	0.024 / 0.6	0.04 / 1	6	320	640	0.64
GEZ50ET-2RS	2 / 50.8	3.1875 / 80.963	1.75 / 44.45	1.5 / 38.1	2.869 / 73	0.024 / 0.6	0.04 / 1	6	415	830	0.93
GEZ57ET-2RS	2.25 / 57.15	3.5625 / 90.488	1.969 / 50.013	1.687 / 42.85	3.223 / 82	0.024 / 0.6	0.04 / 1	6	525	1050	1.3
GEZ63ET-2RS	2.5 / 63.5	3.9375 / 100.013	2.187 / 55.55	1.875 / 47.625	3.616 / 92	0.04 / 1	0.04 / 1	6	655	1310	1.85
GEZ69ET-2RS	2.75 / 69.85	4.375 / 111.125	2.406 / 61.112	2.062 / 52.375	3.937 / 100	0.04 / 1	0.04 / 1	6	785	1570	2.4
GEZ76ET-2RS	3 / 76.2	4.75 / 120.65	2.625 / 66.675	2.25 / 57.15	4.303 / 109.5	0.04 / 1	0.04 / 1	6	935	1870	3.1
GEZ82ET-2RS	3.25 / 82.55	5.125 / 130.175	2.844 / 72.238	2.437 / 61.9	4.685 / 119	0.04 / 1	0.04 / 1	6	1100	2200	3.8
GEZ88ET-2RS	3.5 / 88.9	5.5 / 139.7	3.062 / 77.775	2.625 / 66.675	5.04 / 128	0.04 / 1	0.04 / 1	6	1280	2560	4.8
GEZ95ET-2RS	3.75 / 95.25	5.875 / 149.225	3.281 / 83.337	2.812 / 71.425	5.393 / 137	0.04 / 1	0.04 / 1	6	1460	2920	5.8
GEZ101ET-2RS	4 / 101.6	6.25 / 158.75	3.5 / 88.9	3 / 76.2	5.748 / 146	0.04 / 1	0.04 / 1	6	1660	3320	7
GEZ107ET-2RS	4.25 / 107.95	6.625 / 168.275	3.719 / 94.463	3.187 / 80.95	6.102 / 155	0.04 / 1	0.04 / 1	6	1880	3760	8.41
GEZ114ET-2RS	4.5 / 114.3	7 / 177.8	3.937 / 100.013	3.375 / 85.725	6.476 / 164.5	0.04 / 1	0.04 / 1	6	2110	4220	9.8
GEZ120ET-2RS	4.75 / 120.65	7.375 / 187.325	4.156 / 105.562	3.562 / 90.475	6.83 / 173.5	0.04 / 1	0.04 / 1	6	2350	4700	11.5
GEZ127ET-2RS	5 / 127	7.75 / 196.85	4.375 / 111.125	3.75 / 95.25	7.204 / 183	0.04 / 1	0.04 / 1	6	2610	5220	13.5
GEZ152ET-2RS	6 / 152.4	8.75 / 222.25	4.75 / 120.65	4.125 / 104.775	8.15 / 207	0.04 / 1	0.04 / 1	5	3250	6500	17.5

GEZ... ET are made of carbon chromium steel, fractured, hardened and phosphated, with a sliding surface of PTFE fabric. The inner rings are made of carbon chromium steel and hardened. The sliding surface is treated with chromium plating. The 2RS design has seals at both sides.

# Spherical Plain

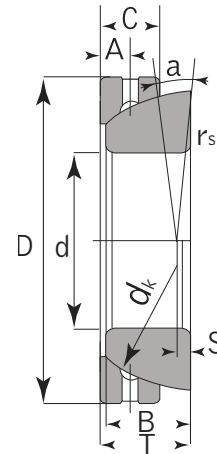

## GACZ S

Bearing Number	Dimensions (inch / mm)										Load Ratings kN		Weight ~kg
	d	D	B	C	T	dk	S	A	max rs r1s	a° ~	Dynamic	Static	
GACZ 12 S	0.5 / 12.7	0.875 / 22.225	0.27 / 6.86	0.19 / 4.83	0.3 / 7.62	0.719 / 18.26	0.051 / 1.3	0.094 / 2.39	0.02 / 0.51	7	6	18	0.013
GACZ 15 S	0.625 / 15.875	1.0625 / 26.988	0.34 / 8.64	0.25 / 6.35	0.37 / 9.4	0.899 / 22.83	0.058 / 1.48	0.109 / 2.77	0.03 / 0.76	6	10	31	0.025
GACZ 19 S	0.75 / 19.05	1.25 / 31.75	0.41 / 10.41	0.31 / 7.87	0.44 / 11.18	1.08 / 27.43	0.07 / 1.79	0.125 / 3.18	0.04 / 1	6	16	47	0.038
GACZ 22 S	0.875 / 22.225	1.4375 / 36.512	0.48 / 12.19	0.38 / 9.65	0.52 / 13.21	1.258 / 31.95	0.08 / 2.02	0.172 / 4.37	0.08 / 2	5.5	22	66	0.049
GACZ 25 S	1 / 25.4	1.625 / 41.275	0.55 / 13.97	0.44 / 11.18	0.6 / 15.24	1.437 / 36.5	0.1 / 2.54	0.203 / 5.16	0.08 / 2	6	29	87	0.085
GACZ 31 S	1.25 / 31.75	2 / 50.8	0.7 / 17.78	0.55 / 13.97	0.74 / 18.8	1.795 / 45.59	0.132 / 3.36	0.234 / 5.94	0.08 / 2	6	47	142	0.159
GACZ 34 S	1.375 / 34.925	2.1875 / 55.562	0.77 / 19.56	0.6 / 15.24	0.84 / 21.34	1.937 / 49.2	0.145 / 3.69	0.281 / 7.14	0.1 / 2.54	4	53	159	0.213
GACZ 38 S	1.5 / 38.1	2.4375 / 61.912	0.84 / 21.34	0.66 / 16.76	0.91 / 23.11	2.155 / 54.74	0.155 / 3.93	0.312 / 7.92	0.1 / 2.54	5.5	66	197	0.301
GACZ 44 S	1.75 / 44.45	2.8125 / 71.438	0.98 / 24.89	0.79 / 20.07	1.07 / 27.18	2.515 / 63.88	0.186 / 4.72	0.328 / 8.33	0.1 / 2.54	6	91	273	0.458
GACZ 50 S	2 / 50.8	3.1875 / 80.962	1.13 / 28.7	0.92 / 23.37	1.23 / 31.24	2.875 / 73.02	0.217 / 5.51	0.375 / 9.52	0.14 / 3.56	5.5	122	365	0.671
GACZ 57 S	2.25 / 57.15	3.5625 / 90.488	1.27 / 32.26	1.05 / 26.67	1.39 / 35.31	3.235 / 82.17	0.243 / 6.18	0.453 / 11.51	0.14 / 3.56	5.5	155	466	0.948
GACZ 63 S	2.5 / 63.5	3.9375 / 100.013	1.42 / 36.07	1.18 / 29.97	1.54 / 39.12	3.59 / 91.19	0.267 / 6.79	0.5 / 12.7	0.14 / 3.56	5	196	589	1.13
GACZ 69 S	2.75 / 69.85	4.375 / 111.125	1.56 / 39.62	1.275 / 32.38	1.7 / 43.18	3.95 / 100.33	0.294 / 7.46	0.515 / 13.08	0.18 / 4.6	5	231	694	1.75
GACZ 76 S	3 / 76.2	4.75 / 120.65	1.71 / 43.43	1.405 / 35.69	1.86 / 47.24	4.312 / 109.52	0.322 / 8.17	0.578 / 14.68	0.18 / 4.6	5	279	838	2.28
GACZ 82 S	3.25 / 82.55	5.125 / 130.175	1.86 / 47.24	1.545 / 39.24	2.03 / 51.56	4.675 / 118.74	0.356 / 9.04	0.656 / 16.66	0.18 / 4.6	5	332	995	2.89
GACZ 88 S	3.5 / 88.9	5.5 / 139.7	2 / 50.8	1.675 / 42.54	2.18 / 55.37	5.04 / 128.02	0.374 / 9.51	0.703 / 17.86	0.18 / 4.6	5	389	1167	3.57
GACZ 95 S	3.75 / 95.25	5.875 / 149.225	2.15 / 54.61	1.805 / 45.85	2.34 / 59.44	5.39 / 136.91	0.398 / 10.1	0.765 / 19.43	0.18 / 4.6	4.5	449	1348	4.35
GACZ 101 S	4 / 101.6	6.25 / 158.75	2.3 / 58.42	1.935 / 49.15	2.5 / 63.5	5.75 / 146.05	0.409 / 10.4	0.781 / 19.84	0.18 / 4.6	4.5	515	1545	5.26
GACZ 114 S	4.5 / 114.3	7 / 177.8	2.59 / 65.79	2.195 / 55.75	2.8 / 71.12	6.475 / 164.46	0.488 / 12.4	0.875 / 22.22	0.18 / 4.6	4.5	663	1990	7.76
GACZ 127 S	5 / 127	7.75 / 196.85	2.88 / 73.15	2.455 / 62.36	3.13 / 79.5	7.19 / 182.63	0.547 / 13.9	1 / 25.4	0.18 / 4.6	4.5	818	2455	11.07
GACZ 152 S	6 / 152.4	8.75 / 222.25	3.1 / 78.74	2.615 / 66.42	3.375 / 85.72	8.156 / 207.16	0.634 / 16.1	1.37 / 34.8	0.18 / 4.6	4.5	985	2955	17.37

# Spherical Plain

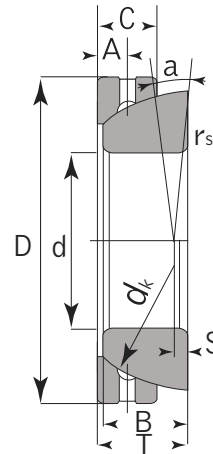

## GAC S

Bearing Number	Dimensions (mm)										Load Ratings kN		Weight ~kg
	d	D	B	C	T	dk	S	A	max r <sub>s</sub>	r <sub>1s</sub>	a° ~	Dynamic	
GAC25S	25	47	15	14	15	42	0.6	7.5	1	2.5	50	250	0.148
GAC28S	28	52	15	15	16	47	1	8	1	2	60	300	0.186
GAC30S	30	55	17	15	17	49.5	1.3	8.5	1	4.5	63	315	0.208
GAC32S	32	58	17	16	17	52	2	8.5	1	2	71	354	0.241
GAC35S	35	62	18	16	18	55.5	2.1	9	1	4	78	390	0.268
GAC40S	40	68	19	17	19	62	2.8	9.5	1	0.5	92	463	0.327
GAC45S	45	75	20	18	20	68.5	3.5	10	1	3	108	540	0.416
GAC50S	50	80	20	19	20	74	4.3	10	1	1.5	123	618	0.455
GAC55S	55	90	23	20	23	82	5	11.5	1.1	4	144	721	0.645
GAC60S	60	95	23	21	23	88.5	5.7	11.5	1.1	2.5	163	817	0.714
GAC65S	65	100	23	22	23	93.5	6.5	11.5	1.1	1	180	905	0.759
GAC70S	70	110	25	23	25	102	7.2	12.5	1.1	2	206	1030	1.04
GAC75S	75	115	25	24	25	107	7.9	12.5	1.1	1	220	1129	1.12
GAC80S	80	125	29	25.5	29	115	8.6	14.5	1.1	3.5	258	1290	1.54
GAC85S	85	130	29	26.5	29	122	9.4	14.5	1.1	2	284	1422	1.61
GAC90S	90	140	32	28	32	128.5	10.1	16	1.5	3.5	316	1580	2.09
GAC95S	95	145	32	29.5	32	135	10.8	16	1.5	2	350	1750	2.22
GAC100S	100	150	32	31	32	141	11.6	16	1.5	0.5	384	1923	2.34
GAC105S	105	160	35	32.5	35	148	12.3	17.5	2	2	423	2116	2.93
GAC110S	110	170	38	34	38	155	13	19	2	3	463	2318	3.68
GAC120S	120	180	38	37	38	168	14.5	19	2	0.5	547	2735	3.97
GAC130S	130	200	45	43	45	188	18	19	2.5	1	710	3550	5.92
GAC140S	140	210	45	43	45	198	19	19	2.5	1	740	3740	6.33
GAC150S	150	225	48	46	48	211	20	20.5	3	1	850	4270	8.01
GAC160S	160	240	51	49	51	225	20	22	3	1	970	4850	9.42
GAC170S	170	260	57	55	57	246	21	27	3	1	1190	5950	12.3
GAC180S	180	280	64	61	64	260	21	28	3	1	1395	6970	17.4
GAC190S	190	290	64	62	64	275	26	30	3	0.5	1500	7500	18.2
GAC200S	200	310	70	66	70	290	26	30	3	1.5	1680	8420	22.5



# Rod End

## Steel on Steel - Inch Series

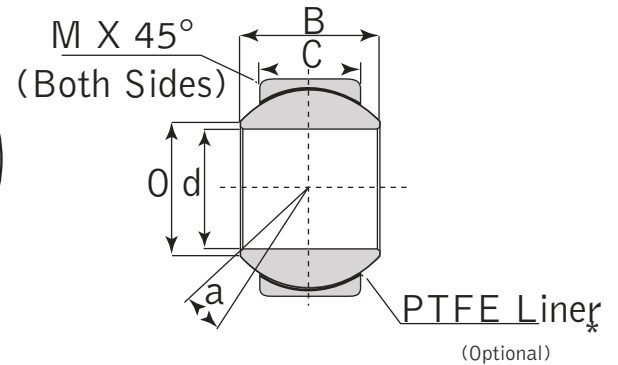
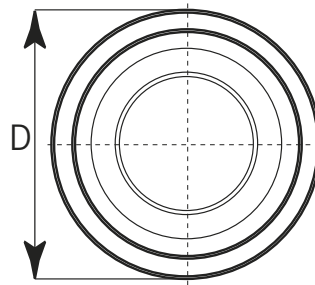

### COM

Unit No.	Dimensions (inch)							Ball Diameter Ref.	Load Rating lbf / N static	Weight lbs
	d	D	C	B	O	M	a			
COM 2	0.1650	0.4687	0.187	0.250	0.235	0.020	9.0	0.343	3 200	0.01
COM 3	0.1900	0.5625	0.218	0.281	0.293	0.015	11.0	0.406	4 875	0.01
COM 4	0.2500	0.6562	0.250	0.343	0.364	0.022	13.5	0.500	7 425	0.02
COM 5	0.3125	0.7500	0.281	0.375	0.419	0.032	12.0	0.562	9 713	0.03
COM 6	0.3750	0.8125	0.312	0.406	0.516	0.032	10.0	0.656	12 600	0.04
COM 7	0.4375	0.9062	0.343	0.437	0.530	0.032	8.0	0.687	14 180	0.05
COM 8	0.5000	1.0000	0.390	0.500	0.640	0.032	9.5	0.781	19 875	0.07
COM 9	0.5625	1.0937	0.437	0.562	0.710	0.032	9.5	0.875	24 945	0.09
COM 10	0.6250	1.1875	0.500	0.625	0.780	0.032	8.5	0.968	31 920	0.11
COM 12	0.7500	1.4375	0.593	0.750	0.920	0.044	9.0	1.187	47 880	0.20
COM 14	0.8750	1.5625	0.703	0.875	0.980	0.044	9.5	1.312	62 940	0.26
COM 16	1.0000	1.7500	0.797	1.000	1.118	0.044	10.0	1.500	82 800	0.39

### HCOM

Unit No.	Dimensions (inch)							Ball Diameter Ref.	Load Rating lbf / N static	Weight lbs
	d	D	C	B	O	M	a			
HCOM 16	1.0000	2.0000	0.781	1.000	1.360	0.032	9.0	1.687	106 230	0.55
HCOM 19	1.1875	2.3750	0.937	1.187	1.610	0.032	8.5	2.000	151 095	0.90
HCOM 20	1.2500	2.3750	0.937	1.187	1.610	0.032	8.5	2.000	151 095	0.90
HCOM 24	1.5000	2.7500	1.094	1.375	1.860	0.032	8.5	2.312	203 925	1.36
HCOM 28	1.7500	3.1250	1.250	1.562	2.110	0.044	8.0	2.625	264 555	1.95
HCOM 32	2.0000	3.5000	1.375	1.750	2.360	0.044	8.5	2.937	325 590	2.66

\*Optional PTFE lining. Add -T after part number.

# Rod End

## Steel-on-Bronze

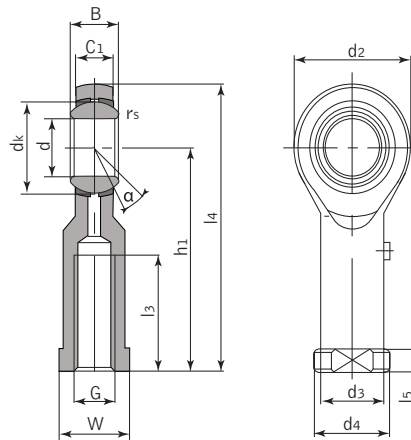

## SIBP

Bearing Number	Dimensions (mm)														Load Ratings kN		Weight ~kg	
	d	B	dK	C1 Max	d2	G 6H	h1	l3 Min	l4	l5	W	d3	d4	rs min	α° ≈	Dynamic		Static
SIBP5S	5	8	11.112	6	16	M5	27	14	35	4	9	9	11	0.3	13	3.3	4.1	0.016
SIBP6S	6	9	12.7	6.75	18	M6	30	14	39	5	11	10	13	0.3	13	4.3	5.3	0.026
SIBP8S	8	12	15.88	9	22	M8	36	17	47	5	14	12.5	16	0.3	14	6.8	8.5	0.044
SIBP10S	10	14	19.05	10.5	26	M10	43	21	56	6.5	17	15	19	0.3	14	10	11	0.072
SIBP10S/B1	10	14	19.05	10.5	26	M10×1.25	43	21	56	6.5	17	15	19	0.3	14	10	11	0.072
SIBP12S	12	16	22.23	12	30	M12	50	24	65	6.5	19	17.5	22	0.3	13	13	14	0.108
SIBP12S/B2	12	16	22.23	12	30	M12×1.25	50	24	65	6.5	19	17.5	22	0.3	13	13	14	0.108
SIBP14S	14	19	25.4	13.5	34	M14	57	27	74	8	22	20	25	0.3	16	17	20	0.161
SIBP14S/B1	14	19	25.4	13.5	34	M14×1.5	57	27	74	8	22	20	25	0.3	16	17	20	0.161
SIBP16S	16	21	28.58	15	38	M16	64	33	83	8	22	22	27	0.3	15	21	25	0.225
SIBP16S/B1	16	21	28.58	15	38	M16×1.5	64	33	83	8	22	22	27	0.3	15	20	25	0.225
SIBP18S	18	23	31.75	16.5	42	M18×1.5	71	36	92	10	27	25	31	0.6	15	26	30	0.295
SIBP20S	20	25	34.93	18	46	M20×1.5	77	40	100	10	30	27.5	34	0.6	15	31	35	0.382
SIBP22S	22	28	38.1	20	50	M22×1.5	84	43	109	12	32	30	37	0.6	15	38	43	0.488
SIBP25S	25	31	42.86	22	60	M24×2	94	48	124	12	36	33.5	42	0.6	15	47	65	0.749
SIBP28S	28	35	47.63	25	66	M27×2	103	53	136	12	41	37	46	0.6	15	59	77	0.949
SIBP30S	30	37	50.8	25	70	M30×2	110	56	145	15	41	40	50	0.6	17	63	86	1.13

Can supply other rod ends with different pitch or accuracy of thread.  
 For left-hand thread suffix "L" is added to bearings number and thread sign e.g. SILBP20S.

# Rod End

## Steel-on-Bronze

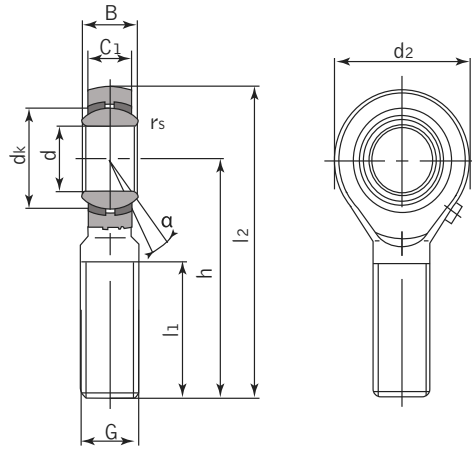

### SABP

Bearing Number	Dimensions (mm)							Load Ratings kN						Weight ~kg
	d	B	dk	C1 Max	d2	G 6G	h	l1 min	l2	rs min	$\alpha^\circ \approx$	Dynamic	Static	
SABP 5S	5	8	11.112	6	16	M5	33	20	41	0.3	13	3.3	3.9	0.016
SABP 6S	6	9	12.7	6.75	18	M6	36	22	45	0.3	13	4.3	5.3	0.026
SABP 8S	8	12	15.88	9	22	M8	42	25	53	0.3	14	6.8	8.5	0.044
SABP 10S	10	14	19.05	10.5	26	M10	48	29	61	0.3	14	10	11	0.072
SABP 10S/B1	10	14	19.05	10.5	26	M10 X 1.25	48	29	61	0.3	14	10	11	0.072
SABP 12S	12	16	22.23	12	30	M12	54	33	69	0.3	13	13	14	0.108
SABP 12S/B2	12	16	22.23	12	30	M12 X 1.25	54	33	69	0.3	13	10	15.8	0.085
SABP 14S	14	19	25.4	13.5	34	M14	60	36	77	0.3	16	17	20	0.161
SABP 14S/B1	14	19	25.4	13.5	34	M14 X 1.5	50	36	77	0.3	16	13	22.1	0.126
SABP 16S	16	21	28.58	15	38	M16	66	40	85	0.3	15	21	25	0.225
SABP 16S/B1	16	21	28.58	15	38	M16 X 1.5	66	40	85	0.3	15	16	25.9	0.185
SABP 18S	18	23	31.75	16.5	42	M18x1.5	72	44	93	0.6	15	26	30	0.295
SABP 20S	20	25	34.93	18	46	M20x1.5	78	47	101	0.6	15	31	35	0.382
SABP 22S	22	28	38.1	20	50	M22x1.5	84	51	109	0.6	15	38	43	0.488
SABP 25S	25	31	42.86	22	60	M24x2	94	57	124	0.6	15	47	65	0.749
SABP 28S	28	35	47.63	25	66	M27x2	103	62	136	0.6	15	59	77	0.949
SABP 30S	30	37	50.8	25	70	M30x2	110	66	145	0.6	17	63	86	1.13

Can supply other rod ends with different pitch or accuracy of thread.

For left-hand thread suffix "L" is added to bearings number and thread sign e.g. SILBP20S.

# Rod End

## Steel-on-Bronze

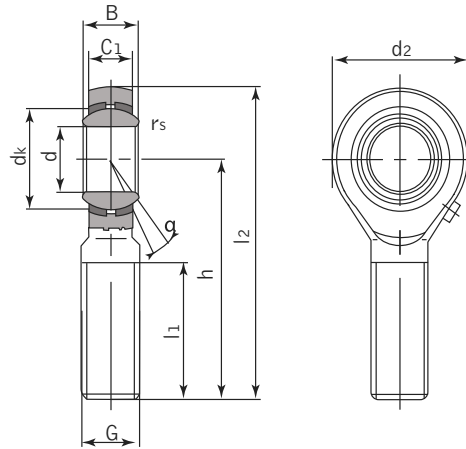

## SAZP

Bearing Number	Dimensions (inch / mm)											Load Ratings kN		Weight ~kg
	d	B	dk	C1 Max	d2	G	h	l1 min	l2	rs min	$\alpha^\circ \approx$	Dynamic	Static	
SAZP4Z	<b>0.19</b> 4.83	<b>0.312</b> 7.92	<b>0.437</b> 11.1	<b>0.25</b> 6.35	<b>0.625</b> 15.88	10-32	<b>1.25</b> 31.75	<b>0.75</b> 19.05	<b>1.563</b> 39.7	<b>0.012</b> 0.3	10	3.4	3.8	0.013
SAZP6Z	<b>0.25</b> 6.35	<b>0.375</b> 9.53	<b>0.5</b> 12.7	<b>0.281</b> 7.14	<b>0.75</b> 19.05	1/4-28	<b>1.562</b> 39.67	<b>1</b> 25.4	<b>1.937</b> 49.2	<b>0.012</b> 0.3	13	4.5	6.6	0.022
SAZP7Z	<b>0.3125</b> 7.94	<b>0.437</b> 11.1	<b>0.625</b> 15.88	<b>0.344</b> 8.74	<b>0.875</b> 22.23	5/16-24	<b>1.875</b> 47.63	<b>1.25</b> 31.75	<b>2.312</b> 58.72	<b>0.012</b> 0.3	10	6.9	8.4	0.037
SAZP9Z	<b>0.375</b> 9.53	<b>0.5</b> 12.7	<b>0.719</b> 18.26	<b>0.406</b> 10.31	<b>1</b> 25.4	3/8-24	<b>1.938</b> 49.23	<b>1.25</b> 31.75	<b>2.438</b> 61.93	<b>0.024</b> 0.6	9	9.4	10	0.055
SAZP11Z	<b>0.4375</b> 11.11	<b>0.562</b> 14.27	<b>0.812</b> 20.62	<b>0.437</b> 11.1	<b>1.125</b> 28.58	7/16-20	<b>2.125</b> 53.98	<b>1.375</b> 34.93	<b>2.688</b> 68.28	<b>0.024</b> 0.6	11	11	13	0.078
SAZP12Z	<b>0.5</b> 12.7	<b>0.625</b> 15.88	<b>0.937</b> 23.81	<b>0.5</b> 12.7	<b>1.312</b> 33.32	1/2-20	<b>2.438</b> 61.93	<b>1.5</b> 38.1	<b>3.094</b> 78.59	<b>0.024</b> 0.6	9	15	19	0.12
SAZP15Z	<b>0.625</b> 15.88	<b>0.75</b> 19.05	<b>1.125</b> 28.58	<b>0.562</b> 14.27	<b>1.5</b> 38.1	5/8-18	<b>2.625</b> 66.68	<b>1.625</b> 41.28	<b>3.375</b> 85.73	<b>0.024</b> 0.6	11	20	21	0.18
SAZP19Z	<b>0.75</b> 19.05	<b>0.875</b> 22.23	<b>1.312</b> 33.32	<b>0.687</b> 17.45	<b>1.75</b> 44.45	3/4-16	<b>2.875</b> 73.03	<b>1.75</b> 44.45	<b>3.75</b> 95.25	<b>0.024</b> 0.6	10	29	29	0.29
SAZP25Z	<b>1</b> 25.4	<b>1.375</b> 34.93	<b>1.875</b> 47.63	<b>1</b> 25.4	<b>2.75</b> 69.85	1 1/4-12	<b>4.125</b> 104.78	<b>2.125</b> 53.98	<b>5.5</b> 139.7	<b>0.024</b> 0.6	14	60	101	1.1

For left-hand thread, suffix "L" is added to bearings number e.g. SALZP12Z.

# Rod End

## Steel-on-Bronze

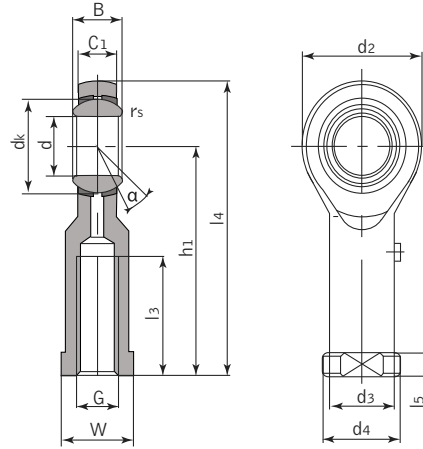

### SIZP

Bearing Number	Dimensions (inch / mm)															Load Ratings kN		Weight ~kg
	d	B	dK	C1 Max	d2	G	h1	l3 Min	l4	l5	W	d3	d4	rs Min	$\alpha^\circ$ $\approx$	Dynamic	Static	
SIZP4Z	<b>0.187</b> 4.83	<b>7.92</b> 0.312	<b>0.437</b> 11.1	<b>0.25</b> 6.35	<b>0.625</b> 15.88	10-32	<b>1.062</b> 26.97	<b>0.562</b> 14.27	<b>1.375</b> 34.93	<b>0.187</b> 4.75	<b>0.312</b> 7.92	<b>0.297</b> 7.54	<b>0.406</b> 10.31	<b>0.012</b> 0.3	10	3.4	4.6	0.015
SIZP6Z	<b>0.25</b> 6.35	<b>0.375</b> 9.53	<b>0.5</b> 12.7	<b>0.281</b> 7.14	<b>0.750</b> 19.05	1/4-28	<b>1.312</b> 33.32	<b>0.75</b> 19.05	<b>1.687</b> 42.85	<b>0.187</b> 4.75	<b>0.375</b> 9.53	<b>0.36</b> 9.15	<b>0.469</b> 11.91	<b>0.012</b> 0.3	13	4.5	7.7	0.025
SIZP7Z	<b>0.3125</b> 7.94	<b>0.437</b> 11.1	<b>0.625</b> 15.88	<b>0.344</b> 8.74	<b>0.875</b> 22.23	5/16-24	<b>1.375</b> 34.93	<b>0.750</b> 19.05	<b>1.812</b> 46.02	<b>0.187</b> 4.75	<b>0.437</b> 11.1	<b>0.422</b> 10.72	<b>0.5</b> 12.7	<b>0.012</b> 0.3	10	6.9	8.4	0.036
SIZP9Z	<b>0.375</b> 9.53	<b>0.5</b> 12.7	<b>0.719</b> 18.26	<b>0.406</b> 10.31	<b>1</b> 25.4	3/8-24	<b>1.625</b> 41.28	<b>0.937</b> 23.81	<b>2.125</b> 53.98	<b>0.25</b> 6.35	<b>14.27</b> 0.562	<b>0.547</b> 13.89	<b>17.45</b> 0.687	<b>0.024</b> 0.6	9	9.4	10	0.061
SIZP11Z	<b>0.437</b> 11.1	<b>0.562</b> 14.27	<b>0.812</b> 20.62	<b>0.437</b> 11.1	<b>1.125</b> 28.58	7/16-20	<b>1.812</b> 46.02	<b>1.062</b> 26.97	<b>2.375</b> 60.33	<b>0.25</b> 6.35	<b>0.625</b> 15.88	<b>0.61</b> 15.49	<b>0.750</b> 19.05	<b>0.024</b> 0.6	11	11	13	0.081
SIZP12Z	<b>0.5</b> 12.7	<b>0.625</b> 15.88	<b>0.937</b> 23.81	<b>0.5</b> 12.7	<b>1.312</b> 33.32	1/2-20	<b>2.125</b> 53.98	<b>1.187</b> 30.15	<b>2.781</b> 70.64	<b>0.25</b> 6.35	<b>0.750</b> 19.05	<b>0.735</b> 18.67	<b>0.875</b> 22.23	<b>0.024</b> 0.6	9	15	19	0.133
SIZP15Z	<b>0.625</b> 15.88	<b>0.750</b> 19.05	<b>1.125</b> 28.58	<b>0.562</b> 14.27	<b>1.5</b> 38.1	5/8-18	<b>2.5</b> 63.5	<b>1.5</b> 38.1	<b>3.25</b> 82.55	<b>0.312</b> 7.92	<b>0.875</b> 22.23	<b>0.86</b> 21.84	<b>1</b> 25.4	<b>0.024</b> 0.6	11	20	21	0.19
SIZP19Z	<b>0.750</b> 19.05	<b>0.875</b> 22.23	<b>1.312</b> 33.32	<b>0.687</b> 17.45	<b>1.75</b> 44.45	3/4-16	<b>2.875</b> 73.03	<b>1.75</b> 44.45	<b>3.75</b> 95.25	<b>0.312</b> 7.92	<b>1</b> 25.4	<b>0.985</b> 25.02	<b>1.125</b> 28.58	<b>0.024</b> 0.6	10	29	29	0.285
SIZP25Z	<b>1</b> 25.4	<b>1.375</b> 34.93	<b>1.875</b> 47.63	<b>1</b> 25.4	<b>2.75</b> 69.85	1 1/4-12	<b>4.125</b> 104.78	<b>2.125</b> 53.98	<b>5.5</b> 139.7	<b>0.437</b> 11.1	<b>1.5</b> 38.1	<b>1.485</b> 37.72	<b>1.75</b> 44.45	<b>0.024</b> 0.6	14	60	101	1

For left-hand thread suffix "L" is added to bearings number e.g. SILZP12Z.

# Rod End

## Steel-on-Steel

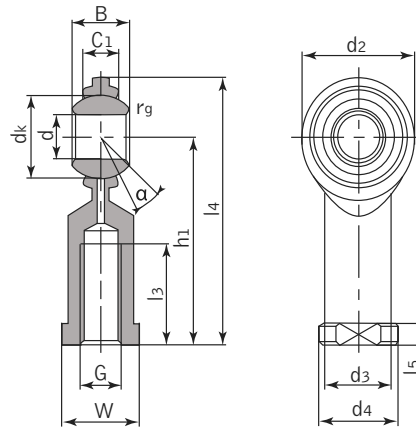

## SIZJ

Bearing Number	Dimensions (inch / mm)															Load Ratings kN		Weight ~kg
	d	B	dK	C1 MAX	d2	G	h1	l3 Min	l4	l5	W	d3	d4	rs Min	α° ≈	Dynamic	Static	
SIZJ4	<b>0.19</b> 4.83	<b>0.312</b> 7.92	<b>0.437</b> 11.1	<b>0.234</b> 5.94	<b>0.625</b> 15.88	10-32	<b>1.062</b> 26.97	<b>0.5</b> 12.7	<b>1.375</b> 34.93	<b>0.187</b> 4.75	<b>0.312</b> 7.92	<b>0.297</b> 7.54	<b>0.406</b> 10.31	<b>0.012</b> 0.3	10	3.6	6.8	0.018
SIZJ6	<b>0.25</b> 6.35	<b>0.375</b> 9.53	<b>0.5</b> 12.7	<b>0.25</b> 6.35	<b>0.75</b> 19.05	1/4-28	<b>1.312</b> 33.32	<b>0.625</b> 15.88	<b>1.687</b> 42.85	<b>0.187</b> 4.75	<b>0.375</b> 9.53	<b>0.36</b> 9.15	<b>0.469</b> 11.91	<b>0.012</b> 0.3	13.5	5.4	9.6	0.023
SIZJ7	<b>0.3125</b> 7.94	<b>0.437</b> 11.1	<b>0.625</b> 15.88	<b>0.312</b> 7.92	<b>0.875</b> 22.23	5/16-24	<b>1.375</b> 34.93	<b>0.625</b> 15.88	<b>1.812</b> 46.02	<b>0.187</b> 4.75	<b>0.437</b> 11.1	<b>0.422</b> 10.72	<b>0.5</b> 12.7	<b>0.012</b> 0.3	11	8.5	12	0.036
SIZJ9	<b>0.375</b> 9.53	<b>0.5</b> 12.7	<b>0.719</b> 18.26	<b>0.359</b> 9.12	<b>1</b> 25.4	3/8-24	<b>1.625</b> 41.28	<b>0.75</b> 19.05	<b>2.125</b> 53.98	<b>0.25</b> 6.35	<b>0.562</b> 14.27	<b>0.547</b> 13.89	<b>17.45</b> 0.687	<b>0.024</b> 0.6	11	11	16	0.059
SIZJ11	<b>0.4375</b> 11.11	<b>0.562</b> 14.27	<b>0.812</b> 20.62	<b>0.406</b> 10.31	<b>1.125</b> 28.58	7/16-20	<b>1.812</b> 46.02	<b>0.875</b> 22.23	<b>2.375</b> 60.33	<b>0.25</b> 6.35	<b>0.625</b> 15.88	<b>0.61</b> 15.49	<b>0.75</b> 19.05	<b>0.024</b> 0.6	10.5	14	21	0.082
SIZJ12	<b>0.5</b> 12.7	<b>0.625</b> 15.88	<b>0.937</b> 23.81	<b>0.453</b> 11.5	<b>1.312</b> 33.32	1/2-20	<b>2.125</b> 53.98	<b>1</b> 25.4	<b>2.781</b> 70.64	<b>0.25</b> 6.35	<b>0.75</b> 19.05	<b>0.735</b> 18.67	<b>0.875</b> 22.23	<b>0.024</b> 0.6	10	18	28	0.132
SIZJ15	<b>0.625</b> 15.88	<b>0.75</b> 19.05	<b>1.125</b> 28.58	<b>0.484</b> 12.29	<b>1.5</b> 38.1	5/8-18	<b>2.5</b> 63.5	<b>1.25</b> 31.75	<b>3.25</b> 82.55	<b>0.312</b> 7.92	<b>0.875</b> 22.23	<b>0.86</b> 21.84	<b>1</b> 25.4	<b>0.024</b> 0.6	13	23	29	0.195
SIZJ19	<b>0.75</b> 19.05	<b>0.875</b> 22.23	<b>1.312</b> 33.32	<b>0.593</b> 15.06	<b>1.75</b> 44.45	3/4-16	<b>2.875</b> 73.03	<b>1.375</b> 34.93	<b>3.75</b> 95.25	<b>0.312</b> 7.92	<b>1</b> 25.4	<b>0.985</b> 25.02	<b>1.125</b> 28.58	<b>0.024</b> 0.6	12	34	44	0.295

For left-hand thread suffix "L" is added to bearings number e.g. SILZJ12.  
Also available with grease fitting, add letter "G" at the end e.g. SIZJ19G.

# Rod End

## Steel-on-Steel

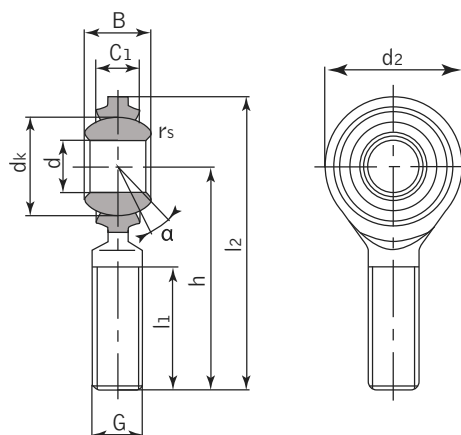

### SAZJ

Bearing Number	Dimensions (inch / mm)											Load Ratings kN		Weight ~kg
	d	B	dK	C1 MAX	d2	G	h	l1 Min	l2	rs min	$\alpha^\circ \approx$	Dynamic	Static	
SAZJ4	<b>0.19</b> 4.83	<b>0.312</b> 7.92	<b>0.437</b> 11.1	<b>0.234</b> 5.94	<b>0.625</b> 15.88	10-32	<b>1.25</b> 31.75	<b>0.75</b> 19.05	<b>1.563</b> 39.7	<b>0.012</b> 0.3	10	3.6	3.8	0.014
SAZJ6	<b>0.25</b> 6.35	<b>0.375</b> 9.53	<b>0.5</b> 12.7	<b>0.25</b> 6.35	<b>0.75</b> 19.05	1/4-28	<b>1.562</b> 39.67	<b>1</b> 25.4	<b>1.937</b> 49.2	<b>0.012</b> 0.3	13.5	5.4	6.6	0.018
SAZJ7	<b>0.3125</b> 7.94	<b>0.437</b> 11.1	<b>0.625</b> 15.88	<b>0.312</b> 7.92	<b>0.875</b> 22.23	5/16-24	<b>1.875</b> 47.63	<b>1.25</b> 31.75	<b>2.312</b> 58.72	<b>0.012</b> 0.3	11	8.5	12	0.032
SAZJ9	<b>0.375</b> 9.53	<b>0.5</b> 12.7	<b>0.719</b> 18.26	<b>0.359</b> 9.12	<b>1</b> 25.4	3/8-24	<b>1.938</b> 49.23	<b>1.25</b> 31.75	<b>2.438</b> 61.93	<b>0.024</b> 0.6	11	11	16	0.05
SAZJ11	<b>0.4375</b> 11.11	<b>0.562</b> 14.27	<b>0.812</b> 20.62	<b>0.406</b> 10.31	<b>1.125</b> 28.58	7/16-20	<b>2.125</b> 53.98	<b>1.375</b> 34.93	<b>2.688</b> 68.28	<b>0.024</b> 0.6	10.5	14	21	0.068
SAZJ12	<b>0.5</b> 12.7	<b>0.625</b> 15.88	<b>0.937</b> 23.81	<b>0.453</b> 11.5	<b>1.312</b> 33.32	1/2-20	<b>2.438</b> 61.93	<b>1.5</b> 38.1	<b>3.094</b> 78.59	<b>0.024</b> 0.6	10	18	28	0.11
SAZJ15	<b>0.625</b> 15.88	<b>0.75</b> 19.05	<b>1.125</b> 28.58	<b>0.484</b> 12.29	<b>1.5</b> 38.1	5/8-18	<b>2.625</b> 66.68	<b>1.625</b> 41.28	<b>3.375</b> 85.73	<b>0.024</b> 0.6	13	23	29	0.16
SAZJ19	<b>0.75</b> 19.05	<b>0.875</b> 22.23	<b>1.312</b> 33.32	<b>0.593</b> 15.06	<b>1.75</b> 44.45	3/4-16	<b>2.875</b> 73.03	<b>1.75</b> 44.45	<b>3.75</b> 95.25	<b>0.024</b> 0.6	12	34	44	0.26

For left-hand thread suffix "L" is added to bearings number e.g. SALZJ12.  
Also available with grease fitting, add letter "G" at the end e.g. SAZJ19G.



# Bearing Kits

## Trailer Kits



### TK 1000

This kit for a 1" axis includes the following:

- 2 pces. L44610 Bearing Cup
- 2 pces. L 44643 Tapered Bearing
- 1 pce. 1.219" x 1.980" x 0.406" Oil Seal
- 1 pce. Grease Pack
- 1 pce. Cotter Pin

### TK 1063

This Kit for a 1-1/16" axis includes the following:

- 2 pces. L44610 Bearing Cup
- 2 pces. L 44649 Tapered Bearing
- 1 pce. 1.250" x 1.9790" x 0.252" Oil Seal
- 1 pce. Grease Pack
- 1 pce. Cotter Pin

### TK 3500

This Kit for a 3500lbs. axis includes the following:

- 1 pces. L 68111 Bearing Cup
- 1 pces. L 44610 Bearing Cup
- 1 pces. L 68149 Tapered Bearing
- 1 pce. L 44649 Tapered Bearing
- 1 pce. 1.718" x 2.561" x 0500" Oil Seal
- 1 pce. Grease Pack
- 1 pce. Cotter Pin

## Snowmobile Bearings



### Bearings for snowmobiles beacon 325 grease Low temperature -55°C to +120°C

- 6004 2RK C3 LT (Low Temp)
- 6005 2RK C3 LT (Low Temp)
- 6202 2RK C3 LT (Low Temp)
- 6204 2RK C3 LT (Low Temp)
- 6205 2RK C3 LT (Low Temp)
- 6205-16 2RK C3 LT (Low Temp)

Double Lip Seals, Blue Color



# Hvac Bearings

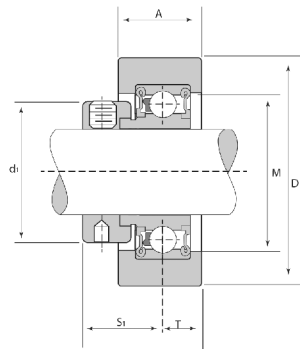

RCSM

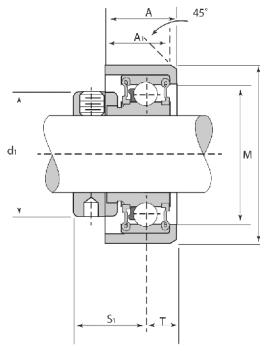

RCR / LRCR

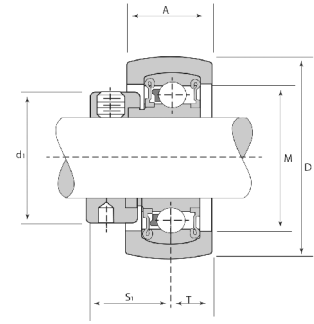

RABR

## RCR & LRCR

Locking Collar Unit No.	Bore	inch / mm	inch / mm	inch / mm	inch / mm	inch / mm	inch / mm	inch / mm	Bearing No.	Rubber Insert No.	Rating lbs N Dynamic Cr	Weight lbs / Kg
	inch / mm											
RCSM 17 1/2 5/8	<b>17</b> 1/2 5/8	2-17/32 <b>64.3</b>	<b>1</b> 25.4	-	1-3/8 <b>34.9</b>	1-1/8 <b>28.5</b>	7/8 <b>22.2</b>	1/2 <b>12.7</b>	CSA 203 201-8 202-10	RC-3	<b>200</b> 880	<b>0.87</b> 0.395
RCSM 20 3/4	<b>20</b> 3/4	2-17/32 <b>64.3</b>	<b>1</b> 25.4	-	1-8/16 <b>39.7</b>	1-5/16 <b>33.3</b>	59/64 <b>23.4</b>	1/2 <b>12.7</b>	CSA 204 204-12	RC-4	<b>250</b> 1120	<b>1.04</b> 0.472
RCSM 25 15/16 1	<b>25</b> 15/16 1	2-17/32 <b>64.3</b>	<b>1</b> 25.4	-	1-25/32 <b>42.2</b>	1-1/2 <b>38.1</b>	59/64 <b>23.4</b>	1/2 <b>12.7</b>	CSA 205 205-15 205-16	RC-5	<b>300</b> 1340	<b>1.16</b> 0.527
LRCSM 1-3/16	1-3/16	2-17/32 <b>64.3</b>	<b>1</b> 25.4	-	1-7/8 <b>47.6</b>	1-21/32 <b>42.1</b>	25/32 <b>19.8</b>	1/2 <b>12.7</b>	CSA 206-19	RC-6	<b>300</b> 1340	<b>1.38</b> 0.627
<b>RCR Series</b>												
LRCR 3/4	3/4	1-13/16 <b>46</b>	23/32 <b>18.3</b>	5/8 <b>15.9</b>	1-3/8 <b>34.9</b>	1-3/16 <b>30.2</b>	47/64 <b>18.7</b>	25/64 <b>9.9</b>	CSA 104-12	LRCR-12	<b>200</b> 880	<b>0.6</b> 0.272
RCR 25 1	<b>25</b> 1	2-1/4 <b>57.2</b>	25/32 <b>19.8</b>	11/16 <b>17.5</b>	1-3/4 <b>44.4</b>	1-1/2 <b>38.1</b>	59/64 <b>23.4</b>	25/64 <b>9.9</b>	CSA 205 205-16	RCR-16	<b>300</b> 1340	<b>0.9</b> 0.41

## RABR

Locking Collar Unit No.	Bore	inch / mm	inch / mm	inch / mm	inch / mm	inch / mm	inch / mm	inch / mm	Bearing No.	Rubber Insert No.	Rating lbs N Dynamic Cr	Weight lbs / Kg
	inch / mm											
RABR 17 1/2 5/8	<b>17</b> 1/2 5/8	1.865 <b>47.37</b>	1-1/8 <b>28.6</b>	11/16 <b>17.5</b>	1-3/8 <b>34.9</b>	1-1/8 <b>28.6</b>	7/8 <b>22.2</b>	11/32 <b>8.7</b>	SA 203 201-8 202-10	R-4	<b>200</b> 880	<b>0.87</b> 0.395
RABR 20 3/4	<b>20</b> 3/4	2.062 <b>53.37</b>	1-7/32 <b>31</b>	11/16 <b>17.5</b>	1-5/8 <b>41.3</b>	1-5/16 <b>33.3</b>	59/64 <b>23.4</b>	59/64 <b>8.7</b>	SA 204 204-12	R-5	<b>250</b> 1120	<b>1.04</b> 0.472
RABR 25 15/16 1	<b>25</b> 15/16 1	2.456 <b>62.38</b>	1-7/32 <b>31</b>	13/16 <b>20.6</b>	1-27/32 <b>46.8</b>	1-1/2 <b>38.1</b>	59/64 <b>23.4</b>	13/32 <b>10.3</b>	SA 205 205-15 205-16	R-6	<b>300</b> 1340	<b>1.16</b> 0.527
RABR 30 1-3/16	<b>30</b> 1-3/16	2-27/32 <b>72.38</b>	1-13/32 <b>35.7</b>	7/8 <b>22</b>	2-7/16 <b>62</b>	1-3/4 <b>44.4</b>	1-1/8 <b>28.6</b>	13/32 <b>10.3</b>	SA 206 206-19	R-7	<b>300</b> 1340	<b>1.38</b> 0.627



# Mast Guide Bearings

## Technical Illustrations

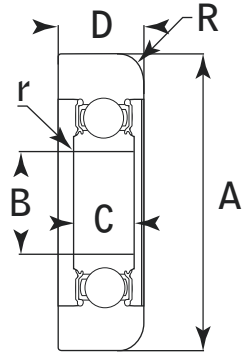

Style 1

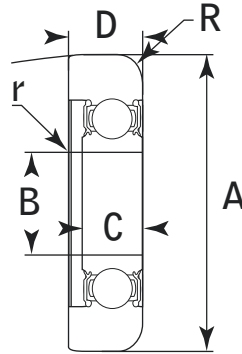

Style 1B

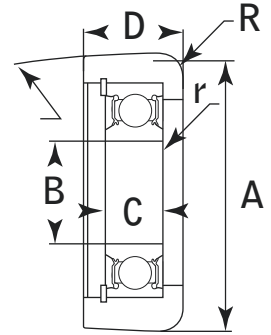

Style 2A

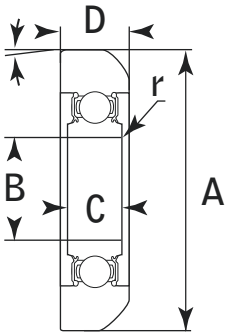

Style 3

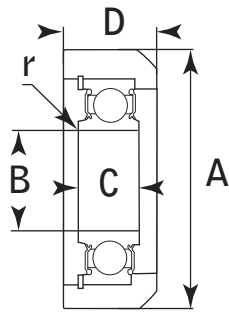

Style 4

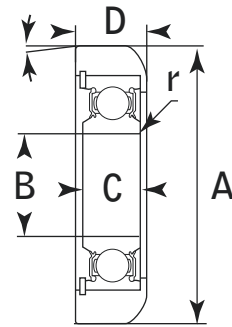

Style 4A

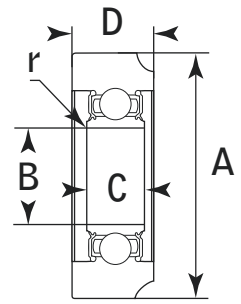

Style 5

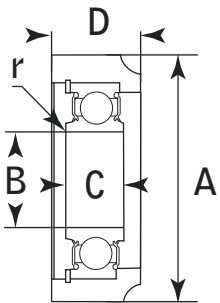

Style 6

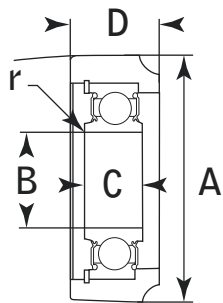

Style 6A

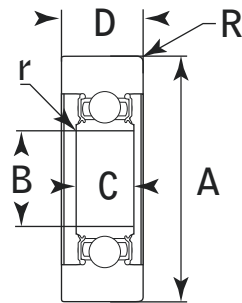

Style 7

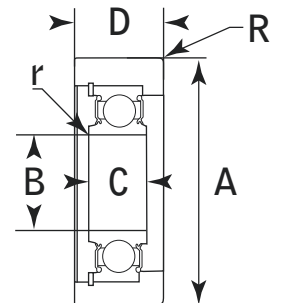

Style 8

# Mast Guide Bearings



Bearing No.	Style	Bore (inch / <b>mm</b> ) B	Outside Dia. ( <b>inch</b> ) A	Inner Ring (inch / <b>mm</b> ) C	Outer Ring ( <b>inch</b> ) D	Radius R	Fillet *r
MG-205-FF	1	0.9843 / <b>25</b>	2.5630	0.5890 / <b>14.96</b>	0.8380	0.2460	0.0590
MG-305-DDB	1B	0.9843 / <b>25</b>	3	0.6693 / <b>17</b>	1	0.25	0.04
MG-305-DD	1	0.9843 / <b>25</b>	3.0000	0.6693 / <b>17</b>	1.0000	0.3300	0.0400
MG-305-DDE	1	0.9843 / <b>25</b>	3.1320	0.6681 / <b>16.97</b>	0.9450	0.2360	0.0980

Bearing No.	Style	Bore (inch / <b>mm</b> ) B	Outside Dia. ( <b>inch</b> ) A	Inner Ring (inch / <b>mm</b> ) C	Outer Ring ( <b>inch</b> ) D	Radius R	Fillet *r
MG-305-DDA	1	1.0000 / <b>25.4</b>	2.9370	0.6693 / <b>17</b>	1.0000	0.3300	0.0400

Bearing No.	Style	Bore (inch / <b>mm</b> ) B	Outside Dia. ( <b>inch</b> ) A	Inner Ring (inch / <b>mm</b> ) C	Outer Ring ( <b>inch</b> ) D	Radius R	Fillet *r
MG-206-FFZ	2A	1.1811 / <b>30</b>	3.139	0.653 / <b>16.59</b>	1.125	0.19	0.04
MG-206-FFZA	2A	1.1811 / <b>30</b>	3.169	0.653 / <b>16.59</b>	1.125	0.19	0.04
MG-206-FFU	2A	1.1811 / <b>30</b>	3.194	0.653 / <b>16.59</b>	1.152	0.236	0.04
MG-206-FFZB	2A	1.1811 / <b>30</b>	3.199	0.653 / <b>16.59</b>	1.125	0.19	0.04
MG-206-FFM	4A	1.1811 / <b>30</b>	3.2	0.7712 / <b>19.58</b>	1	-	0.04
MG-206-FFA	3	1.1811 / <b>30</b>	3.2	0.7712 / <b>19.58</b>	1	-	0.04
MG-206-FFUA	2A	1.1811 / <b>30</b>	3.214	0.653 / <b>16.59</b>	1.152	0.236	0.04
MG-206-FFUB	2A	1.1811 / <b>30</b>	3.234	0.653 / <b>16.59</b>	1.152	0.236	0.04
MG-306-DDB	1	1.1811 / <b>30</b>	3.2500	0.7480 / <b>19</b>	1.0620	0.3430	0.0400
MG-306-FFB	1	1.1811 / <b>30</b>	3.2500	0.7480 / <b>19</b>	1.0620	0.3430	0.0400
MG-206-FFK	2A	1.1811 / <b>30</b>	3.4	0.653 / <b>16.59</b>	1.125	0.25	0.04
MG-206-FFKA	2A	1.1811 / <b>30</b>	3.4	0.653 / <b>16.59</b>	1.125	0.25	0.04
MG-206-FFW	2A	1.1811 / <b>30</b>	3.414	0.653 / <b>16.59</b>	1.125	0.19	0.04
MG-206-FFWA	2A	1.1811 / <b>30</b>	3.444	0.653 / <b>16.59</b>	1.125	0.19	0.04
MG-206-FFP	2A	1.1811 / <b>30</b>	3.47	0.653 / <b>16.59</b>	1.152	0.236	0.04
MG-206-FFWB	2A	1.1811 / <b>30</b>	3.474	0.653 / <b>16.59</b>	1.125	0.19	0.04
MG-206-FFPA	2A	1.1811 / <b>30</b>	3.4855	0.653 / <b>16.59</b>	1.152	0.236	0.04
MG-306-DD	1	1.1811 / <b>30</b>	3.5000	0.7480 / <b>19</b>	1.0000	0.3750	0.0400
MG-306-FF	1	1.1811 / <b>30</b>	3.5000	0.7480 / <b>19</b>	1.0000	0.3750	0.0400
MG-206-FFPB	2A	1.1811 / <b>30</b>	3.5055	0.653 / <b>16.59</b>	1.152	0.236	0.04



# Mast Guide Bearings

Bearing No.	Style	Bore (inch / <b>mm</b> ) B	Outside Dia. ( <b>inch</b> ) A	Inner Ring (inch / <b>mm</b> ) C	Outer Ring ( <b>inch</b> ) D	Radius R	Fillet *r
MG-207-FFP	6A	1.378 / <b>35</b>	3.592	0.7874 / <b>20</b>	1.255	-	0.04
MG-207-FFJ	6A	1.378 / <b>35</b>	3.592	0.7874 / <b>20</b>	1.255	-	0.04
MG-207-FFH	6A	1.378 / <b>35</b>	3.592	0.8268 / <b>21</b>	1.255	-	0.04
MG-207-FFJA	2A	1.378 / <b>35</b>	3.619	0.653 / <b>16.59</b>	1.255	0.315	0.04
MG-307-FFJB	1	1.3780 / <b>35</b>	3.7250	0.6693 / <b>17</b>	0.9960	0.3120	0.0400
MG-307-FFJB	1	1.3780 / <b>35</b>	3.7250	0.8268 / <b>21</b>	1.0000	0.3750	0.0600
MG-307-FFK	1	1.3780 / <b>35</b>	3.7250	0.8268 / <b>21</b>	1.0000	0.3750	0.0600
MG-307-FFWK	1	1.3780 / <b>35</b>	3.7750	0.8268 / <b>21</b>	1.1220	0.2760	0.0980
MG-307-FFWP	1	1.3780 / <b>35</b>	3.7750	0.8268 / <b>21</b>	1.1220	0.2760	0.0980
MG-307-FFWR	1	1.3780 / <b>35</b>	3.7550	0.8268 / <b>21</b>	0.9960	0.3150	0.0600
MG-207-FFQB	2A	1.378 / <b>35</b>	3.962	0.653 / <b>16.59</b>	1.192	0.31	0.04
MG-307-FFB	7	1.378 / <b>35</b>	3.98	0.748 / <b>19</b>	1.255	0.125	0.06
MG-207-FFU	2A	1.378 / <b>35</b>	3.990	0.653 / <b>16.59</b>	1.125	0.276	0.06
MG-307-FFP	1B	1.3780 / <b>35</b>	3.99	0.8268 / <b>21</b>	1.25	0.276	0.06
MG-307-FFE	5	1.378 / <b>35</b>	3.99	0.8268 / <b>21</b>	1.125	-	0.06
MG-307-FFH	1	1.3780 / <b>35</b>	3.9900	0.8268 / <b>21</b>	1.1250	0.3700	0.0600
MG-207-FFM	6	1.378 / <b>35</b>	3.991	0.8268 / <b>21</b>	1.125	-	0.04
MG-307-FFM	1B	1.3780 / <b>35</b>	3.993	0.8268 / <b>21</b>	1.125	0.24	0.06
MG-307-FFA	1	1.3780 / <b>35</b>	4.0000	0.8268 / <b>21</b>	1.1250	0.3750	0.0600
MG-307-FFHA	1	1.3780 / <b>35</b>	4.0150	0.8268 / <b>21</b>	1.1250	0.3750	0.0590
MG-207-FFQA	2A	1.378 / <b>35</b>	4.373	0.653 / <b>16.59</b>	1.192	0.31	0.04
MG-207-FFQ	6A	1.378 / <b>35</b>	4.373	0.7874 / <b>20</b>	1.192	-	0.06
MG-207-FFU	6A	1.378 / <b>35</b>	4.382	0.6693 / <b>17</b>	1.192	-	0.04
MG-207-FFK	6A	1.378 / <b>35</b>	4.382	0.8268 / <b>21</b>	1.192	-	0.04
MG-307-FFQ	4	1.378 / <b>35</b>	4.49	-	1.255	-	0.04
MG-307-FFQB	4	1.378 / <b>35</b>	4.49	-	1.255	-	0.04

# Mast Guide Bearings



Bearing No.	Style	Bore (inch / <b>mm</b> ) B	Outside Dia. ( <b>inch</b> ) A	Inner Ring (inch / <b>mm</b> ) C	Outer Ring ( <b>inch</b> ) D	Radius R	Fillet *r
MG-208-FFB	3	1.5748 / <b>40</b>	3.942	0.7087 / <b>18</b>	1	-	0.04
MG-208-FFM	3	1.5748 / <b>40</b>	4	0.7712/ <b>19.58</b>	1	-	0.04
MG-308-FFH	1	1.5748 / <b>40</b>	4.0000	0.9055 / <b>23</b>	1.1250	0.2500	0.0600
MG-308-FFAB	1B	1.5748 / <b>40</b>	4.2786	0.9055 / <b>23</b>	1.22	0.236	0.059
MG-308-FFAC	1B	1.5748 / <b>40</b>	4.318	0.9055 / <b>23</b>	1.22	0.236	0.059
MG-308-FFPA	1	1.5748 / <b>40</b>	4.3390	0.9055 / <b>23</b>	1.2800	0.2760	0.0980
MG-308-FFAD	1B	1.5748 / <b>40</b>	4.3613	0.9055 / <b>23</b>	1.22	0.236	0.059
MG-308-FFPB	1	1.5748 / <b>40</b>	4.3740	0.9055 / <b>23</b>	1.2800	0.2760	0.0980
MG-308-FFA	1	1.5748 / <b>40</b>	4.4860	0.9055 / <b>23</b>	1.2500	0.3750	0.0600
MG-308-FFE	1	1.5748 / <b>40</b>	4.4960	0.9055 / <b>23</b>	1.1100	0.2460	0.0600

Bearing No.	Style	Bore (inch / <b>mm</b> ) B	Outside Dia. ( <b>inch</b> ) A	Inner Ring (inch / <b>mm</b> ) C	Outer Ring ( <b>inch</b> ) D	Radius R	Fillet *r
MG-309-DD	7	1.7717 / <b>45</b>	3.975	0.9843 / <b>25</b>	1.121	0.125	0.08
MG-309-DDH	7	1.7717 / <b>45</b>	4.75	0.8268 / <b>21</b>	1.25	0.125	0.04
MG-309-DDE	3	1.7717 / <b>45</b>	4.942	0.9843 / <b>25</b>	1.515	-	0.06
MG-309-DDB	1B	1.7717 / <b>45</b>	5.0025	0.9843 / <b>25</b>	1.25	0.3125	0.04
MG-309-DDA	1	1.7717 / <b>45</b>	5.0030	0.9843 / <b>25</b>	1.2500	0.3125	0.0600
MG-309-DDBA	1B	1.7717 / <b>45</b>	5.034	0.9055 / <b>23</b>	1.25	0.3125	0.06

Bearing No.	Style	Bore (inch / <b>mm</b> ) B	Outside Dia. ( <b>inch</b> ) A	Inner Ring (inch / <b>mm</b> ) C	Outer Ring ( <b>inch</b> ) D	Radius R	Fillet *r
MG-311-FFA	1	2.1654 / <b>55</b>	5.9800	1.1417 / <b>29</b>	1.5000	0.4375	0.0400
MG-311-ZZA	1	2.1654 / <b>55</b>	5.9800	1.1417 / <b>29</b>	1.5000	0.4375	0.0800
MG-311-FF	1	2.1654 / <b>55</b>	6.4680	1.1417 / <b>29</b>	1.5000	0.4375	0.0400
MG-311-ZZ	1	2.1654 / <b>55</b>	6.4680	1.1417 / <b>29</b>	1.5000	0.4375	0.0800



# Solid Shaft Collar

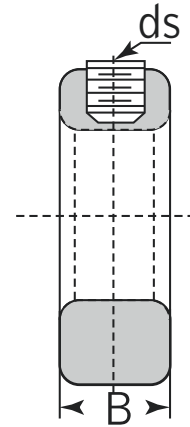
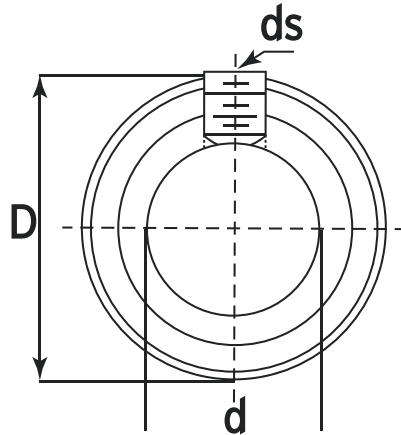

GRB Part number	Bore «d»	O.D. «D»	Width «B»
SC 1/8	1/8	0.355	0.250
<b>SC 3/16</b>	<b>3/16</b>	<b>0.418</b>	<b>0.250</b>
SC 1/4	1/4	0.480	2.810
<b>SC 5/16</b>	<b>5/16</b>	<b>0.605</b>	<b>0.313</b>
<b>SC 3/8</b>	<b>3/8</b>	<b>0.730</b>	<b>0.375</b>
<b>SC 7/16</b>	<b>7/16</b>	<b>0.855</b>	<b>0.437</b>
<b>SC 1/2</b>	<b>1/2</b>	<b>0.980</b>	<b>0.437</b>
SC 9/16	9/16	0.980	0.437
<b>SC 5/8</b>	<b>5/8</b>	<b>1.105</b>	<b>0.500</b>
SC 11/16	11/16	1.230	0.562
<b>SC 3/4</b>	<b>3/4</b>	<b>1.230</b>	<b>0.562</b>
<b>SC 13/16</b>	<b>13/16</b>	<b>1.480</b>	<b>0.562</b>
<b>SC 7/8</b>	<b>7/8</b>	<b>1.480</b>	<b>0.562</b>
SC 15/16	15/16	1.605	0.562
<b>SC 1</b>	<b>1</b>	<b>1.605</b>	<b>0.625</b>
<b>SC 1-1/16</b>	<b>1-1/16</b>	<b>1.730</b>	<b>0.625</b>
SC 1-1/8	1-1/8	1.730	0.625
SC 1-3/16	1-3/16	1.975	0.687
<b>SC 1-1/4</b>	<b>1-1/4</b>	<b>1.975</b>	<b>0.687</b>
<b>SC 1-5/16</b>	<b>1-5/16</b>	<b>2.100</b>	<b>0.687</b>
<b>SC 1-3/8</b>	<b>1-3/8</b>	<b>2.100</b>	<b>0.750</b>
<b>SC 1-7/16</b>	<b>1-7/16</b>	<b>2.225</b>	<b>0.750</b>
<b>SC 1-1/2</b>	<b>1-1/2</b>	<b>2.225</b>	<b>0.813</b>
SC 1-9/16	1-9/16	2.480	0.813
<b>SC 1-5/8</b>	<b>1-5/8</b>	<b>2.480</b>	<b>0.813</b>

GRB Part number	Bore «d»	O.D. «D»	Width «B»
SC 1-11/16	1 11/16	2.480	0.813
SC 1-3/4	1 3/4	2.720	0.875
SC 1-13/16	1 13/16	2.720	0.875
SC 1-7/8	1 7/8	2.720	0.875
SC 1-15/16	1 15/16	2.975	0.875
SC 2	2	2.975	0.875
SC 2-1/8	2 1/8	2.975	0.875
SC 2-3/16	2 3/16	3.225	0.937
SC 2-1/4	2 1/4	3.225	0.937
SC 2-5/16	2 5/16	3.225	0.937
SC 2-3/8	2 3/8	3.225	0.937
SC 2-7/16	2 7/16	3.470	1.000
SC 2-1/2	2 1/2	3.470	1.000
SC 2-9/16	2 9/16	3.720	1.125
SC 2-5/8	2 5/8	3.720	1.125
SC 2-11/16	2 11/16	3.970	1.125
SC 2-3/4	2 3/4	3.970	1.125
SC 2-13/16	2 13/16	3.970	1.125
SC 2-7/8	2 7/8	4.220	1.125
SC 2-15/16	2 15/16	4.220	1.125
SC 3	3	4.220	1.125
SC 3-3/16	3 3/16	4.220	1.125
SC 3-7/16	3 7/16	4.470	1.125
SC 3-15/16	3 15/16	4.970	1.125
SC 4-7/16	4 7/16	5.970	1.375
SC 4-15/16	4 15/16	6.400	1.375

## Standard Tolerances

Dimensions (Bore)	Tolerances
1/8" - 3"	+0.001 - +0.003
3" - 4 15/16"	+0.001 - +0.004

**Items in bold** = stock items  
 other sizes available  
 on request  
 Some sizes available  
 in zinc plated or  
 black oxide finish

# Double Split Shaft Collar

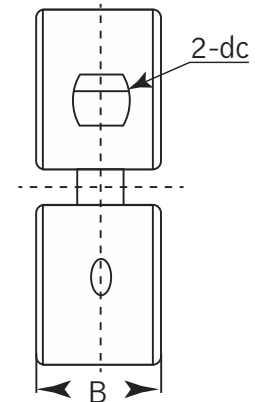
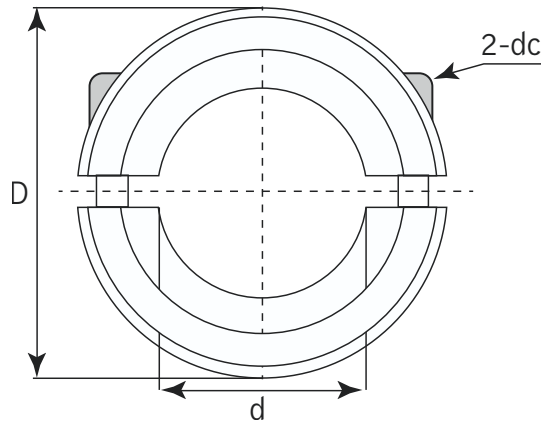

GRB Part number	Bore «d»	O.D. «D»	Width «B»
2SC 1/8	1/8	1/2	1/4
<b>2SC 3/16</b>	<b>3/16</b>	<b>5/8</b>	<b>5/16</b>
2SC 1/4	1/4	11/16	5/16
<b>2SC 5/16</b>	<b>5/16</b>	<b>11/16</b>	<b>5/16</b>
<b>2SC 3/8</b>	<b>3/8</b>	<b>7/8</b>	<b>11/32</b>
<b>2SC 7/16</b>	<b>7/16</b>	<b>15/16</b>	<b>3/8</b>
<b>2SC 1/2</b>	<b>1/2</b>	<b>1 1/8</b>	<b>13/32</b>
2SC 9/16	9/16	1 1/4	7/16
<b>2SC 5/8</b>	<b>5/8</b>	<b>1 5/16</b>	<b>7/16</b>
2SC 11/16	11/16	1 3/8	7/16
<b>2SC 3/4</b>	<b>3/4</b>	<b>1 1/2</b>	<b>1/2</b>
<b>2SC 13/16</b>	<b>13/16</b>	<b>1 5/8</b>	<b>1/2</b>
<b>2SC 7/8</b>	<b>7/8</b>	<b>1 5/8</b>	<b>1/2</b>
2SC 15/16	15/16	1 3/4	1/2
<b>2SC 1</b>	<b>1</b>	<b>1 3/4</b>	<b>1/2</b>
<b>2SC 1 1/16</b>	<b>1 1/16</b>	<b>1 7/8</b>	<b>1/2</b>
2SC 1 1/8	1 1/8	1 7/8	1/2
2SC 1 3/16	1 3/16	2 1/16	1/2
<b>2SC 1 1/4</b>	<b>1 1/4</b>	<b>2 1/16</b>	<b>1/2</b>
<b>2SC 1 5/16</b>	<b>1 5/16</b>	<b>2 1/8</b>	<b>9/16</b>
<b>2SC 1 3/8</b>	<b>1 3/8</b>	<b>2 1/4</b>	<b>9/16</b>
<b>2SC 1 7/16</b>	<b>1 7/16</b>	<b>2 1/4</b>	<b>9/16</b>
<b>2SC 1 1/2</b>	<b>1 1/2</b>	<b>2 3/8</b>	<b>9/16</b>
2SC 1 9/16	1 9/16	2 3/8	9/16
2SC 1 5/8	1 5/8	2 5/8	11/16

GRB Part number	Bore «d»	O.D. «D»	Width «B»
2SC 1 11/16	1 11/16	2 3/4	11/16
2SC 1 3/4	1 3/4	2 3/4	11/16
2SC 1 13/16	1 13/16	2 7/8	11/16
2SC 1 7/8	1 7/8	2 7/8	11/16
2SC 1 15/16	1 15/16	3	11/16
<b>2SC 2</b>	<b>2</b>	<b>3</b>	<b>11/16</b>
2SC 2 1/16	2 1/16	3 1/8	3/4
2SC 2 1/8	2 1/8	3 1/4	3/4
2SC 2 3/16	2 3/16	3 1/4	3/4
2SC 2 1/4	2 1/4	3 1/4	3/4
<b>2SC 2 5/16</b>	<b>2 5/16</b>	<b>3 3/8</b>	<b>3/4</b>
2SC 2 3/8	2 3/8	3 1/2	3/4
2SC 2 7/16	2 7/16	3 1/2	3/4
<b>2SC 2 1/2</b>	<b>2 1/2</b>	<b>3 3/4</b>	<b>7/8</b>
2SC 2 9/16	2 9/16	3 7/8	7/8
2SC 2 5/8	2 5/8	3 7/8	7/8
2SC 2 11/16	2 11/16	4	7/8
2SC 2 3/4	2 3/4	4	7/8
2SC 2 13/16	2 13/16	4 1/4	7/8
2SC 7/8	2 7/8	4 1/4	7/8
2SC 2 15/16	2 15/16	4 1/4	7/8
2SC 3	3	4 1/4	7/8
2SC 3 3/16	3 3/16	4 1/2	7/8
2SC 3 7/16	3 7/16	4 3/4	7/8
2SC 3 1/2	3 1/2	4 3/4	7/8
2SC 3 15/16	3 15/16	5 1/4	7/8

## Standard Tolerances

Dimensions (Bore)	Tolerances
1/8" - 3"	+0.001 - +0.003
3" - 3 15/16"	+0.001 - +0.004

**Items in bold** = stock items  
other sizes available  
on request



# Bearing Tolerances

## Metric Bearings

The tolerances indicated on the following pages conform to the Anti-Friction Bearing Manufacturers Association (AFBMA) and the International Standards Organization (ISO) standards.

These bearings are available in Tolerance Classes, STANDARD (ABEC-1) (no markings), P/6 (ABEC-3), P/5 (ABEC-5) and P/4 (ABEC-7). Bearings in Tolerance Classes P/5 (ABEC-5) and P/4 (ABEC-7) are generally used in special applications such as machine tool spindles. GRB normally keeps the ABEC-1 Standard bearings in stock.

## Inch Bearings

Our inch series bearings are only available in STANDARD Tolerance Class, which conform to British Standards for external dimension limits and running accuracy.

**To clarify the headings and symbols used in these Tolerance Tables, the following definitions will apply:**

- d** Nominal bearing bore diameter
- d min** The minimum diameter reading obtained by two-point measurements of a bearing bore having out-of-roundness and taper
- d max** The maximum diameter reading obtained by two-point measurements of a bearing bore having out-of-roundness and taper
- dm**  $(d \max + d \min / 2)$  which is the mean bore diameter for a particular bearing
- D** Nominal bearing outside diameter
- D min** The minimum diameter reading obtained by two-point measurements of a bearing outside surface having out-of-roundness and taper
- D max** The maximum diameter reading obtained by two-point measurements of a bearing outside surface having out-of-roundness and taper
- Dm**  $(D \max + D \min / 2)$  which is the mean outside diameter for a particular bearing
- B** Width of bearing



# Ball Bearing Tolerances



Radial Bearings - Metric (except Metric Tapered Roller Bearings)

## Tolerance Class - STANDARD (ABEC-1)

### Outer Ring

Outer Ring Nominal O.D. Diameter (Metric)		Outside Diameter Tolerances (inch)				Width Tolerances (inch)	
D		DM		D min	D max	B	
Over	Incl.	High	Low	Maximum	Minimum		
6	18	0	-0.0003	0.0001	-0.0004	Tolerances are identical to those of inner ring of the the same bearing	
18	30	0	-0.00035	0.0001	-0.0004		
30	50	0	-0.0004	0.0001	-0.00055		
50	80	0	-0.0005	0.00015	-0.0007		
80	120	0	-0.0006	0.0002	-0.0008		
120	150	0	-0.0007	0.00025	-0.00095		
150	180	0	-0.0010	0.0003	-0.00125		
180	250	0	-0.0012	0.0003	-0.0015		
250	315	0	-0.0014	0.00035	-0.0017		
315	400	0	-0.0016	0.0004	-0.002		
400	500	0	-0.0018	0.0005	-0.00225		
500	630	0	-0.0020	0.00055	-0.0025		
630	800	0	-0.00295	0.0007	-0.0036		
800	1000	0	-0.0039	0.0008	-0.0047		

### Inner Ring

Inner Ring Nominal Bore Diameter (Metric)		Bore Tolerances (inch)				Width Tolerances (inch)	
d		dm		d min	d max	B	
Over	Incl.	Low	High	Minimum	Maximum	Maximum	Minimum
2.5	10	-0.0003	0	-0.0004	0.0001	0	-0.0045
10	18	-0.0003	0	-0.0004	0.0001	0	-0.0045
18	30	-0.0004	0	-0.0005	0.0001	0	-0.0045
30	50	-0.0005	0	-0.0006	0.0001	0	-0.0045
50	80	-0.0006	0	-0.00075	0.00015	0	-0.006
80	120	-0.0008	0	-0.001	0.0002	0	-0.008
120	180	-0.0010	0	-0.0012	0.00025	0	-0.01
180	250	-0.0012	0	-0.0015	0.0003	0	-0.012
250	315	-0.0014	0	-0.0017	0.00035	0	-0.014
315	400	-0.0016	0	-0.002	0.0004	0	-0.0155
400	500	-0.0018	0	-0.0022	0.0005	0	-0.0175
500	630	-0.0020	0	-0.0025	0.00055	0	-0.02
630	800	-0.00295	0	-0.0035	0.0006	0	-0.0295
800	1000	-0.0039	0	-0.0047	0.0008	0	-0.0395



# Bearing Tolerances

Radial Bearings - Inch (Except Tapered Roller Bearings)

## Outer Ring

Nominal Bore Diameter (inch)		Bore Tolerances (inch)		Width Tolerances (inch)	
d		dm		B	
Over	Incl.	Low	High	Maximum	Minimum
0	1	-0.0003	-0.0007	Tolerances are identical to those of inner ring of the same bearing	
1	2	-0.0003	-0.0008		
2	3	-0.0005	-0.001		
3	5	-0.0008	-0.0013		
5	8	-0.0013	-0.0018		
8	12	-0.0013	-0.0018		
12	15	-0.0013	-0.0023		
15	20	-0.0013	-0.0023		

## Inner Ring

Nominal Bore Diameter (inch)		Bore Tolerances (inch)		Width Tolerances (inch)	
d		dm		B	
Over	Incl.	Low	High	Maximum	Minimum
0	1	-0.0002	0.0002	0	-0.005
1	2	-0.0003	0.0002	0	-0.005
2	3	-0.0003	0.0002	0	-0.005
3	6	-0.0003	0.0002	0	-0.005
6	8	-0.0005	0.0002	0	-0.005
8	12	-0.0005	0.0002	0	-0.01
12	15	-0.0008	0.0002	0	-0.016

## 1600 Series Radial Bearings - Inch

### Outer Ring

Nominal Bore Diameter (inch)		Bore Tolerances (inch)		Width Tolerances (inch)	
D		D		B	
Over	Incl.	Low	High	Maximum	Minimum
0"	1 1/6"	-0.0004	0	0	-0.005
1 1/8"	2 9/16"	-0.0005	0	0	-0.005

### Inner Ring

Nominal Bore Diameter (inch)		Bore Tolerances (inch)		Width Tolerances (inch)	
d		d		B	
Over	Incl.	Low	High	Maximum	Minimum
0"	5/8 "	-0.0003	0	0	-0.005
5/8 "	1 1/8 "	-0.0004	0	0	-0.005
1 1/8 "	1 5/16 "	-0.0005	0	0	-0.005

## Internal Clearance

The Internal Clearance of a bearing is the total distance through which one ring can move relative to the other ring under zero load. This movement in a radial direction is called Radial Internal Clearance and the movement in an axial direction, Axial Internal Clearance.

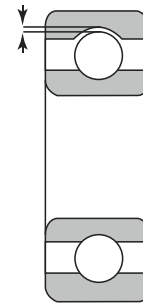

Radial Internal Clearance

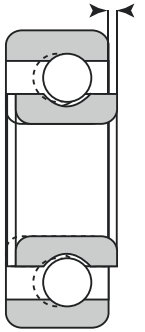

Axial Internal Clearance

The Radial Internal Clearance of a bearing before mounting is greater than when it is installed. The reduction in clearance arises from the expansion of the inner ring or contraction of the outer ring when they are mounted with an interference fit and from the relative heat expansion of the bearing at the operating temperature.

The Internal Clearance of a ball bearing should approach zero when it is mounted and running at its operating temperature. However, for Cylindrical, Tapered and Spherical Roller bearings some Radial Internal Clearance should generally be retained under normal operating conditions. This does not apply, however, when a very rigid bearing arrangement is required, for example, in machine tool spindles.

The standard Internal Radial Clearance values have been established to provide the optimum operating bearing clearance for those applications where normal fits and operating conditions apply. For other conditions, where both outer and inner rings are mounted with an interference fit, bearings with Radial Internal Clearance other than Standard should be selected. In such cases the net clearance remaining after mounting should be checked. Suffixes C/1 through C/5 are used to designate bearings having other than Standard clearance as follows:

- C/1 - Internal Clearance is smaller than C/2
- C/2 - Internal Clearance is smaller than Standard
- **STANDARD** - No clearance marking is indicated on the bearing or packaging
- C/3 - Internal Clearance larger than Standard
- C/4 - Internal Clearance larger than C/3
- C/5 - Internal Clearance larger than C/4

The following Tables indicate the values for the various Internal Clearance groups which conform to the International Standards Organization (ISO) and The Anti-Friction Bearing Manufacturers Association (AFBMA) standards. These values apply to bearings prior to mounting and under zero load.

Another similar system is commonly used in applications involving **Miniature Ball bearings** with a bore diameter under 10mm.

- A tight radial play would be expressed as MC1 or MC2 for metric bearings, or P02 or P13 for inch size bearings
- A medium radial play would be expressed as MC3 or MC4 for metric bearings, or P24 or P35 for inch size bearings
- A loose radial play would be expressed as MC5 or MC6 for metric bearings, or P58 or P811 for inch size bearings



# Fit Charts

Figure 1.1

Bearing Rotation And Load	Illustration	Ring Load	Fit
Inner ring: rotating Outer ring: stationary Load direction: constant	Static load	Rotating inner ring load	Inner Ring: tight fit
Inner Ring: stationary Outer Ring: rotating Load direction: rotates with outer ring	Unbalanced load	Static outer ring load	Outer Ring: loose fit
Inner ring: stationary Outer ring: rotating Load direction: constant	Static load	Static inner ring load	Inner Ring: loose fit
Inner ring: rotating Outer ring: stationary Load direction: rotates with outer ring	Unbalanced load	Rotating outer ring load	Outer Ring: tight fit

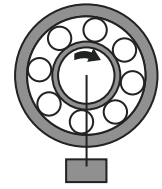

Static Load

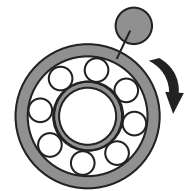

Unbalanced Load

Figure 1.2

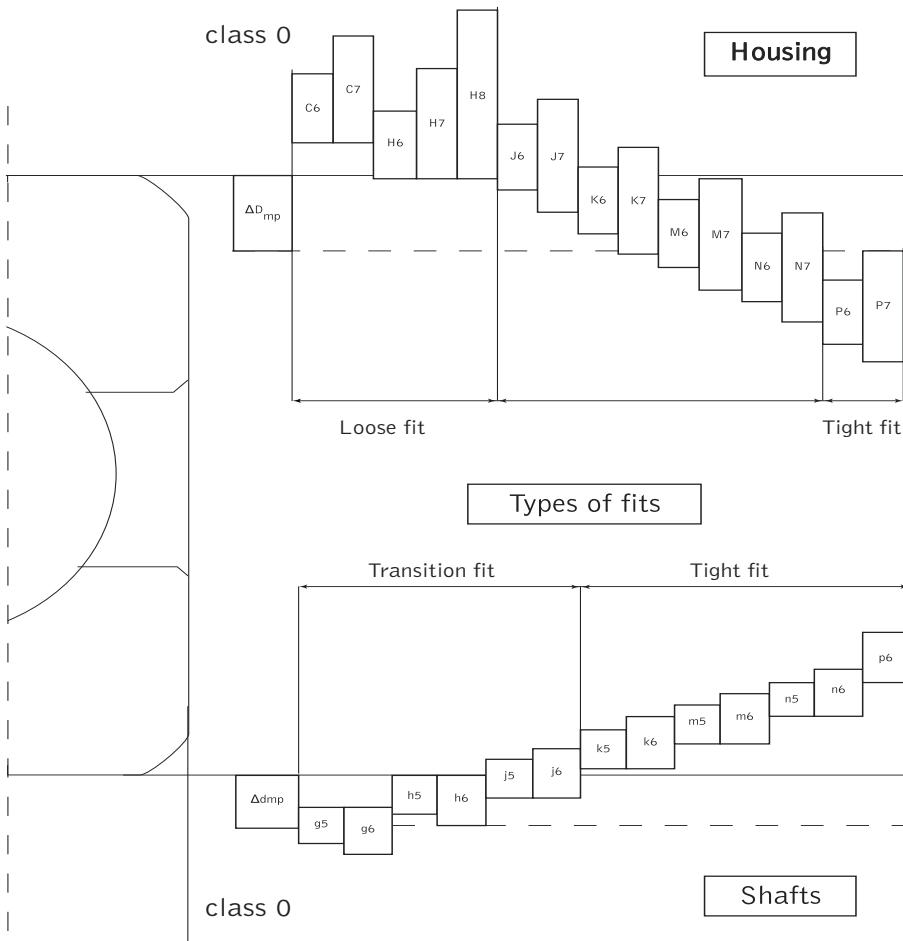



## Shaft Fits

Type Of Load		Shaft Diameter	Shaft Fits
Axial load only for all thrust bearings		All sizes	js6
Combined load: spherical roller thrust bearings	Static inner ring loads	All sizes	js6
	Inner ring rotating load or direction indeterminate	-200	k6
		200-400	m6
		400-	n6

## Housing Fits

Load Conditions		Housing Fits	Notes
Axial load only All thrust bearings	When another bearing is used to support radial load	–	Clearance given between outer ring and housing
		H8	Accuracy required with thrust ball bearings
Combined load: Spherical roller thrust bearings	Static outer ring load	H7	–
	Outer ring rotating load or direction indeterminate load	K7	Normal usage conditions
		M7	Medium to heavy loads

# Needle Roller Bearing Fits

## Shaft Fits

Conditions			Shaft Fits
Load Type	Type Of Load	Shaft Diameter	
Rotating inner ring or indeterminate direction load	Light load	-50	j5
	Normal load	-50	k5
		50 -150	m5
		150-	m6
	Heavy load and shock load	-150	m6
		150-	n6
Static inner ring load	Medium and low speed revolution. Light load	All sizes	g6
	General application	All sizes	h6
	Requiring high speed rotation	All sizes	h5



# Needle Roller Bearing Fits

## Housing Fits

Conditions		Shaft Fits
Load Type	Type of Load	
Static inner ring load	Normal to heavy load	j7
	Outer ring rotating load	H7
Outer ring rotating load	Light loads	M7
	Normal loads	N7
	Heavy and normal loads	P7
Direction indeterminate load	Light loads	J7
	Normal loads	K7
	Very heavy and shock loads	M7

## Fitting Values for Radial Ball Bearings

( $\mu\text{m}$ )								
Nominal Bore Diameter d (mm)		Tolerance of Bore Diameter	g5	g6	h5	h6	j5	j5
over	incl.	( $\mu\text{m}$ )						
3	6	0 -8	-4 ~ +9	-4 ~ +12	~	~	~	~
6	10	0 -8	-3 ~ +11	-3 ~ +14	~	~	~	~
10	18	0 -8	-2 ~ +14	-2 ~ +17	~	~	~	~
18	30	0 -10	-3 ~ +16	-3 ~ +20	~	~	~	~
30	50	0 -12	-3 ~ +20	-3 ~ +25	~	~	~	~
50	80	0 -15	-5 ~ +23	-5 ~ +29	~	~	~	~
80	120	0 -20	-8 ~ +27	-8 ~ +34	~	~	~	~
120	140	0 -25	-11 ~ +32	-11 ~ +39	~	~	~	~
140	160							
160	180							
180	200	0 -30	-15 ~ +35	-15 ~ +44	~	~	~	~
200	225							
225	250							
250	280	0 -35	-18 ~ +40	-18 ~ +49	~	~	~	~
280	315							
315	355							
355	400	0 -40	-22 ~ +43	-22 ~ +54	~	~	~	~
400	450							
450	500							
400	450	0 -45	-25 ~ +47	-25 ~ +60	~	~	~	~
450	500							



## Shaft Fits

Bearing Type	Load Conditions		Ball Bearings	Cylindrical and Tapered Ball Bearings	Spherical Roller Bearings	Shaft Fits
			Shaft Diameter (mm)			
Cylindrical bore bearings	Rotating inner ring or indeterminate direction load	Light or fluctuating variable load	-18	-	-	h5
			18 - 100	-40	-	js6
			100 - 200	40 - 140	-	k6
			-	140 - 200	-	m6
		Normal to heavy load	-18	-	-	js5
			18 - 100	-40	-40	k5
			100 - 140	40 - 100	40 - 65	m5
			140 - 200	100 - 140	65 - 100	m6
			200 - 280	140 - 200	100 - 140	n6
			-	200 - 400	140 - 280	p6
			-	-	280 - 500	r6
			-	50 - 140	50 - 100	n6
	Very heavy or shock load	-	140 - 200	100 - 140	p6	
		-	200 -	140 -	r6	
		All shaft diameters			g6	
Static inner ring load	Inner ring axial displacement required	All shaft diameters			g6	
	Easy axial displacement of inner ring not required	All shaft diameters			h6	

## Housing Fits

Housing Type	Load Conditions		Housing Fit
Solid or split housing	Outer ring static load	All load conditions	H7
		Heat conducted through shaft	G7
Solid housing	Direction indeterminate load	Light to normal	JS7
		Normal to heavy load	K7
		heavy shock load	M7
	Outer ring rotating load	Light or variable load	M7
		Normal to heavy load	N7
Heavy load (thin wall housing) Heavy shock load		P7	



# Technical Data

## Dimension Deviation

- Δds:** Single bore diameter deviation
- Δdmp:** Single plane mean bore diameter deviation
- Δd2mp:** Single plane mean bore diameter deviation (for double direction thrust ball bearing)
- ΔDs:** Single outside diameter deviation
- ΔDmp:** Single plane mean outside diameter deviation
- ΔBs:** Inner ring width deviation, or center washer height deviation
- ΔCs:** Outer ring width deviation
- ΔTs:** Overall width deviation of assembled single row tapered roller bearing, or height deviation of single direction thrust bearing
- ΔT1s:** Height deviation of double direction thrust ball bearing, or effective width deviation of roller and inner ring assembly of tapered roller bearing
- ΔT2s:** Double direction thrust ball bearing housing washer back face height deviation, or tapered roller bearing outer ring effective width deviation

## Chamfer Boundary

- rs min:** Minimum allowable chamfer dimension for inner /outer ring, or small end of inner ring on tapered roller bearing
- rs max:** Maximum allowable chamfer dimension for inner /outer ring, or large end of inner ring on tapered roller bearing
- r1s min:** Minimum allowable chamfer dimension for double direction thrust ball bearing center washer, small end of inner/outer ring of angular contact ball bearing, large end of outer ring of tapered roller bearing
- r1s max:** Maximum allowable chamfer dimension for double direction thrust ball bearing center washer, small end of inner/outer ring of angular contact ball bearing, large end of outer ring of tapered roller bearing
- r2s max:** Maximum allowable chamfer dimension for small end of inner/outer ring of tapered roller bearing

## Dimension Variation

- Vdp:** Single radial plane bore diameter variation
- Vd2p:** Single radial plane bore diameter variation (double direction thrust ball bearing)
- Vdmp:** Mean single plane bore diameter variation
- VDp:** Single radial plane outside diameter variation
- VDmp:** Mean single plane outside diameter variation
- VBs:** Inner ring width variation
- VCs:** Outer ring width variation

## Rotation Tolerance

- Kia:** Inner ring radial runout
- Sia:** Inner ring axial runout (wide side)
- Sd:** Face runout with bore
- Kea:** Outer ring radial runout
- Sea:** Outer ring axial runout
- SD:** Outside surface inclination
- Si:** Thrust bearing shaft washer raceway (or center washer raceway) thickness variation
- Se:** Thrust bearing housing washer raceway thickness variation



# Grease Charts



Grease Name	Dropping Point	Penetration 60x	Thickener	Temp. Range °F	Features
Shell Alvania RL2	385	284	Lithium	-30 to 275	Low Noise – General Purpose & Electric Motors - Replaces Alvania 2/3
Shell Alvania RL3	385	240	Lithium	-30 to 275	
Shell Alvania EP	385	275	Lithium	-10 to 275	Extreme Pressure
Shell Darina 2	500+	280	Microgel	-10 to 350* (*with frequent Lubrication)	High Temperature & Water Resistant
Shell Dolium BRB	500+	285	Polyurea	-30 to 350 (400 short exposure)	High Speed. High Temp. Corrosion Resistant
Exxon Beacon 325	350	285	Lithium	-50 to 250	Low Temperature
Exxon Polyrex EM	550	284	Polyurea	-40 to 350	Electric Motor Grease – High Temp. – Low Noise
Chevron SRI-2	470	280	Polyurea	-20 to 350	High Temp – Excellent Rust Protection
Mobil 28	590	280	Clay (non soap)	-60 to 350	High Temp. High Wear Synthetic Grease – Mil -G81322E
Mobil FM102	400	280	Aluminum Complex	-20 to 175	Food Grade Grease – Water Resistant – Corrosion Protection
Kluber Isoflex LDS18	375	270	Lithium	- 50 to 280	High Speed – Low Noise
Kluber Isoflex NBU15	480	270	Lithium	- 30 to 250	High Speed
Kyodo Yushi Multitemp SRL	365	230	Lithium	-50 to 300	Low Noise



# Conversion Formulas

To Convert To:	To Convert From:	Multiply By:
Bars	Pounds / Square Feet	2089
Centimeters	Feet	0.03281
Centimeters	Inches	0.3937
Degrees Farenheit	Degrees Centigrade	$toC=(toF-32)/1.8$
Degrees Centigrade	Degrees Farenheit	$toF=1.8*toC+32$
Foot	Meter	0.3048
Foot	Millimeter	304.8
Foot / Minute (Fpm)	Meter / Second (M/Min)	0.3048
Foot / Minute (Fpm)	Meter / Second (M/Sec)	0.00508
Inch	Millimeter	25.4
Inch	Meter	0.0254
Inch <sup>2</sup>	Meter <sup>2</sup>	0.000645
Inch / Second (In/Sec)	Meter / Second (M/Sec)	0.0254
Kilograms (Kg)	Pounds (Lbs.)	2.2046
Kilograms / Sq. Centimeter (Kg/Cm <sup>2</sup> )	Pound / Sq. Inch (Psi)	14.223
Kilogram-Force (Kgf)	Newton (N)	9.81
Kilogram-Force-Meter	Newton-Meter (N*M)	9.81
Meter	Feet	3.281
Meter / Minute (M/Min)	Feet / Minute (Fpm)	3.281
Micron	Thousandths	0.03939
Millimeter	Inch	0.03937
Newton (N)	Pound-Force (Lbf)	0.2248
Newton (N)	Kilograms (Kg)	0.1019
Newton-Meter (Nm)	Inch-Pounds	8.851
Newton-Meter (Nm)	Foot-Pound	0.7376
Pounds (Lbs)	Kilograms (Kg)	0.4536
Pound-Force (Lbf)	Newton (N)	4.4482
Pound-Force-Inch (In-Lbs)	Newton-Meter (N*M)	0.11298
Pound-Force-Foot (Ft-Lbs)	Newton-Meter (N*M)	1.3558
Pounds / Inch <sup>2</sup> (Psi)	Kilograms / Centimeter <sup>2</sup> (K/Cm <sup>2</sup> )	0.07028
Pounds / Inch <sup>2</sup> (Psi)	Bar	0.06894
Square Inches (In <sup>2</sup> )	Square Millimeters (Mm <sup>2</sup> )	645.16
Square Millimeters (Mm <sup>2</sup> )	Square Inches (In <sup>2</sup> )	0.00155
Thousandths	Microns	25.4

# Heavy Duty Needle Bearings



GRB needle bearings of type HJ are made of high quality bearing steel. They have a steel cage to keep the needles in and to provide sufficient grease storage. The needles are made of high carbon chrome steel, hardened and ground to close tolerance.



## Lubrication

The HJ outer ring has a lubrication groove in the outside diameter and a lubrication hole in the groove for relubrication through the outer ring. The IR inner ring have lubrication grooves in the bore and a lubrication hole for relubrication through the inner ring.

## Seals

GRB also offers needle bearings with one or two integral rubber seals.

## Mounting Dimensions

Heavy duty needle bearings are normally mounted in their housings with a clearance fit if the load is stationary relative to the housing, and with a tight transition fit if the load rotates relative to the housing. If a tight transition fit of the bearing in the housing is needed, a reduction of the needle complement bore diameter may result. In that case, the shaft raceway diameter may be reduced.

The tables of dimensions list the recommended ISO H7 tolerances for the housing bore and the recommended ISO h6 tolerances for the shaft raceway when the outer ring is to be mounted with a clearance fit. They also list the recommended ISO N7 tolerances for the housing bore and the recommended ISO f6 tolerances for the shaft raceway when the outer ring is to be mounted with a transition fit.



# Rod Ends

Rod ends consist of an eye-shaped head with integral shank forming housing and a standard spherical plain bearing, or a spherical plain bearing inner ring, or a spherical plain bearing inner ring and a sliding layer between the bore of the head and the inner ring. As a rule, rod ends are available with left or right-hand female or male threads. GRB rod ends have the sliding contact surface combinations steel-on-steel, steel-on-bronze, steel-on-PTFE composite material and steel-on-PTFE fabric.



GRB steel-on-steel and steel-on-bronze rod ends have very wear-resistant sliding surfaces and perform well under conditions of lubricant starvation. Rod ends with this sliding contact surface combination require regular relubrication. They are particularly suited for bearing arrangements where heavy alternating loads have to be accommodated.

GRB maintenance-free rod ends sliding contact surfaces have two groups: steel-on-PTFE composite material and steel-on-PTFE fabric. They have very low friction and can be operated without maintenance. They are used for applications where long bearing lives are required without maintenance, or where operating conditions, such as inadequate lubrication or the absence of lubrication make the use of steel-on-steel bearing inadvisable. The maintenance-free bearings are primarily intended for applications where loads are heavy and have a constant direction.

## Design Characteristics

GRB rod end of series SI (A) ... E and SI (A) ... ES is made of carbon steel and is zinc coated to protect against corrosion. Rod end of series SI (A) ZJ... is made of carbon steel and is zinc coated to protect against corrosion. The inner ring is made of carbon chromium steel and hardened. The sliding surface is treated with chromium plating.

GRB steel-on-bronze rod ends comprise a rod end, a spherical plain bearing inner ring and bronze liner. The rod end is made of carbon steel, zinc coated to protect against corrosion. The inner ring is made of carbon chromium steel and hardened. The sliding surface is treated with chromium plating. GRB steel-on-bronze rod ends can be relubricated via a nipple or a hole in the rod end.

GRB steel-on-PTFE composite material rod ends comprise a rod end and a steel-on-PTFE composite material spherical plain bearing. The bearings are held in position in the housing bore axially by staking at both sides. The rod end is made of carbon steel, zinc coated to protect against corrosion. The inner ring is made of carbon chromium steel and hardened. The sliding surface is treated with chromium plating.

Permissible operating temperature range: GRB steel-on-steel and steel-on-PTFE composite material rod ends can be used at temperature  $-50^{\circ}\text{C}$ ~ $+150^{\circ}\text{C}$ .



## Tolerances for Rod Ends

d (mm)		$\Delta h_s$ (mm)		$\Delta h_{1s}$ (mm)	
over	incl.	max	min	max	min
-	6	+0.80	-1.20	+0.65	-1.05
6	20	+0.80	-1.20	+0.80	-1.20
20	30	+1.00	-1.70	+1.00	-1.70
30	45	+1.40	-2.10	+1.40	-2.10
45	60	+1.80	-2.70	+1.80	-2.70
60	80	+2.25	-3.40	+2.25	-3.40
80	125	+2.70	-3.40	+2.70	-3.40
125	200	+3.20	-4.20	+3.20	-4.20

## Symbols of Dimension and Tolerance

D:	Bearing bore diameter, nominal.
$\Delta d_{mp}$ :	Single plane mean bore diameter deviation.
V <sub>d</sub> :	Bore diameter variation in a single radial plane.
V <sub>dmp</sub> :	Mean bore diameter variation.
$\Delta B_s$ :	Deviation of a single width of the inner ring.
B:	Width of inner ring, nominal.
D:	Bearing outside diameter, nominal.
$\Delta D_{mp}$ :	Single plane mean outside diameter deviation.
V <sub>D</sub> :	Outside diameter variation in a single radial plane.
V <sub>Dmp</sub> :	Mean outside diameter variation.
$\Delta C_s$ :	Deviation of a single width of the outer ring.
C:	Width of outer ring, nominal.
$\Delta T_s$ :	Actual deviation of width of the angular contact spherical plain bearing.
$\Delta H_s$ :	Actual deviation of height of the spherical plain thrust bearing.
$\Delta h_s, \Delta h_{1s}$ :	Center height deviation of rod ends or ball joint rod ends.

## Shaft Fits

Operating Conditions	Tolerance
With indeterminate loads	n6. p6
Normal conditions	h6. h7

## Thread

Male Thread	Female Thread
6g	6H
UNF-2A	UNF-2B



# Rod Ends

## Shaft Diameter Tolerances

Shaft Diameter (mm)		Shaft Diameter Tolerances $\mu\text{m}$							
		h6		h7		n6		p6	
over	incl.	high	low	high	low	high	low	high	low
3	6	0	-8	0	-12	+16	+8	+20	+12
6	10	0	-9	0	-15	+19	+10	+24	+15
10	18	0	-11	0	-18	+23	+12	+29	+18
18	30	0	-13	0	-21	+28	+15	+35	+22
30	50	0	-16	0	-25	+33	+17	+42	+26
50	80	0	-19	0	-30	+39	+20	+51	+32
80	120	0	-22	0	-35	+45	+23	+59	+37
120	180	0	-25	0	-40	+52	+27	+68	+43
180	200	0	-29	0	-46	+60	+31	+79	+50

## Radial Internal Clearance of Rod Ends

### Series SI...E. SI...ES. SA...E. SA...ES

d (mm)		Group Normal $\mu\text{m}$	
over	incl.	min	max
-	12	23	68
12	20	30	82
20	35	37	100
35	60	43	120
60	90	55	142
90	125	65	165
125	200	65	192

### Series SI...C. SA...C. SI...ET-2RS. SA...ET-2RS

d (mm)		Group Normal $\mu\text{m}$	
over	incl.	min	max
-	12	0	32
12	20	0	40
20	35	0	50
35	60	0	60
60	80	0	72

### Series SIZJ.... SAZJ....

d (mm)		Group Normal $\mu\text{m}$	
over	incl.	min	max
-	8	10	30
8	14	15	60
14	20	40	80

### Series SIBP...S. SABP...S. SIZP...S. SAZP...S

d (mm)		Group Normal $\mu\text{m}$	
over	incl.	min	max
-	30	0	35

# Radial Spherical Plain Bearings



Radial spherical plain bearings have an inner ring with a spheroid convex outside surface and an outer ring with a correspondingly spheroid but concave inside surface. Their design makes them particularly suitable for bearing arrangements where alignment movements between shaft and housing have to be accommodated, or where oscillating or recurrent tilting or slewing movements must be permitted at relatively slow sliding speeds. GRB radial spherical plain bearings are available with different sliding contact surface combinations, i.e. the sliding surfaces of inner and outer rings are made from different materials.



There are two main groups: spherical plain bearings requiring maintenance (steel-on-steel) and maintenance-free spherical plain bearings.

GRB radial spherical plain bearings requiring maintenance (steel-on-steel) have hardened sliding contact surface on both rings. The surfaces are treated with molybdenum disulphide and are phosphated. It has characteristics of wear-resistance and wear-corrosion. Bearings with this sliding contact surface combination require regular relubrication. The high strength of the sliding contact surfaces makes these bearings especially suitable for bearing arrangements where heavy loads of alternating direction, shock loads or heavy static loads have to be accommodated.

GRB maintenance-free spherical plain bearings sliding contact surfaces have three groups: Steel-on-PTFE composite material, steel-on-PTFE fabric and steel-on-copper alloy. GRB is offering the steel-on-PTFE fabric type. Dynamic load support capability of steel-on-PTFE fabric spherical plain bearings is higher than that of steel-on-PTFE composite material. They have very low friction and can be operated without maintenance. They are used for applications where long bearing lives are required without maintenance, or where operating conditions, such as inadequate lubrication or the absence of lubrication make the use of steel-on-steel bearing inadvisable.

## Design Characteristics

GRB radial spherical plain bearings requiring maintenance (steel-on-steel) are made of carbon chromium steel and are hardened and phosphated. The inner and outer ring sliding contact surfaces are treated with molybdenum disulphide. The outer ring is fractured so that it can be sprung open when the inner ring is inserted. To facilitate efficient lubrication, all bearings have an annular groove and lubrication holes in each ring except those of the E design. Bearings of the 2RS design are fitted with nylon seals or rubbing seals of polyester elastomer at both sides.

The outer rings of series GE... ET-2RS, GEG... ET-2RS and GEZ... ET-2RS are made of carbon chromium steel, fractured, hardened and phosphated, with a sliding surface of PTFE fabric. The inner rings are made of carbon chromium steel and hardened. The sliding surface is treated with chromium plating. The 2RS design has seals at both sides. The outer rings of series GE... XT-2RS and GEG... XT-2RS are made of carbon chromium steel, axially split twice, held together by retaining rings, hardened and phosphated, with sliding surface of PTFE fabric. The inner rings are made of carbon chromium steel, hardened, and the sliding surfaces are treated with chromium plating. The 2RS design has seals at both sides.

Permissible operating temperature range, GRB steel-on-steel, steel-on-PTFE composite material and steel-on-PTFE fabric radial spherical plain bearings can be used at temperature  $-50^{\circ}\sim+150^{\circ}$ . GRB spherical plain bearings with seals can be used at temperature  $-30^{\circ}\sim+130^{\circ}$ . At higher temperature, the load carrying capacity will be reduced.



# Radial Spherical Plain Bearings

## Load Rating

Dynamic rating is used for calculations when the spherical plain bearing is subjected to dynamic stress. It represents the load, constant in magnitude and direction, under which a basic rating service life, expressed as a sliding distance, will be attained for continuous oscillating movement at a defined sliding velocity and at room temperature. It presupposes that the load acting on radial and angular spherical plain bearings and on rod ends is purely radial and that the load acting on spherical plain thrust bearings is purely axial and acts centrally. Dynamic stresses occur when tilting, oscillatory or rotational movements are made under load as well as micro sliding movements under alternating loads, e.g. resulting from vibration, or loads which alternate at high frequency. The various types of dynamic stress often occur in combination.

The values of load ratings are always dependent on the definition used. It is therefore not always possible to make direct comparisons with load ratings published by other manufactures.

The static load rating is used when spherical plain bearings stand still under load (or make occasional alignment movements) and it should also be considered when dynamically loaded bearings are subjected to heavy shock loads. The static load rating represents the load which can be taken up by a spherical plain bearing when static contact stress of bearing contact surface reaches the material stress limit. It is valid at room temperature and it is presupposed that the surrounding components prevent deformation of the bearing. At higher temperature, the static load rating must be multiplied by a temperature factor, depend on the sliding contact surface combination. The temperature factors are the same as for dynamically stressed bearing. It is also necessary to take into consideration the permissible temperature range for the various sliding contact surface combinations. For rod ends, it is the strength of the rod end housing under stationary load which is considered. The rod end static load ratings give a safety factor of 1.2 times the tensile strength of the rod end housing material.

## Service Life

The service life of a spherical plain bearing operated under mixed or dry friction conditions is determined by the increase in bearing clearance or bearing friction caused by progressive wear of the sliding surfaces, plastic deformation of the sliding material or fatigue of the sliding surface. Depending on the application, the permissible wear or permissible increase in friction will be different. This means that under the same operating conditions the service life which can be obtained in practice will be different.

The service life of a spherical plain bearing is the number of oscillating movements, or the number of operating hours, which the bearing will service before a defined increase in bearing clearance or a defined increase in friction is reached.

The effective service life is that life which will be attained by a given spherical plain bearing under actual operating conditions. It is determined by the magnitude and type of load, but also by several other factors, such as contamination, corrosion, high-frequency load and movement cycles, shock etc. Some of these factors are impossible to determine or can only be determined with difficulty.

## Bearing Contact Pressure

If an adequate operating life is to be achieved, a basic requirement is that the bearing contact pressure is compatible with the operating conditions. The bearing contact pressure identifies the surface pressure occurring in the bearing and is a decisive criterion for the assessment of a spherical plain bearing in each individual application.

$$\frac{P}{C_d}$$

$p=k \cdot$   
 $p$ =Contact pressure N/mm<sup>2</sup>  
 $k$ =Contact pressure parameter  
 $C_d$ =Dynamic load rating kN  
 $P$ =Equivalent dynamic bearing load kN

Contact Surface Combination	Value of Load Ratio $C_d/P$
Steel/Steel	2
Steel/Bronze	2
Steel/PTFE Fabric	1.75
Steel/PTFE Composite Material	2
Steel/Copper Alloy	2

Contact Surface Combination	Load Factor $k$
Steel/Steel	100
Steel/Bronze	50
Steel/PTFE Fabric	150
Steel/PTFE Composite Material	100
Steel/Copper Alloy	100



## Bearing Internal Clearance

Bearing internal clearance is defined as the total distance through which one ring can be moved radially (radial internal clearance) or axially (axial internal clearance) in relation to the other ring under a defined measuring load.

It is necessary to distinguish between the internal clearance of a bearing before it is mounted and the internal clearance of a mounted bearing when in operation (operational clearance). The initial clearance will always be greater than the operational clearance because the rings are expanded or compressed by interference fits and as a result of the differences in thermal expansion of the bearing rings and mating components.

The bearing internal clearance referred to as normal has been selected so that when bearings are mounted generally recommended and operate under normal conditions a suitable operational clearance will be obtained. For other conditions, e.g. where, both rings are mounted with an interference fit or where unusual temperatures prevail, bearings with greater or smaller internal clearance than normal may be required.

## Mounting

To facilitate mounting, the ends of pins or shafts and the edges of housing bores should have a lead chamfer of 10 to 20°. The bearings can be more easily pushed into position and there is little risk of damage to the mating surfaces being caused by skewing of the bearing.

When mounting spherical plain bearings with a fractured or two-part outer ring, it is essential that the joint should be positioned at 90° to the main load direction; otherwise the service life will be shortened, particularly under heavy loads.

## Lubrication

For spherical plain bearings requiring maintenance which are of the steel-on-steel type, the purpose of the lubrication is primarily to reduce wear, reduce friction and prevent scuffing. Also the grease serves to protect the bearings against corrosion. The frequency of relubrication of the bearing during its operation will appreciably extend the service life.

For steel-on-PTFE fabric spherical plain bearings, there is a transfer of PTFE from fabric to the opposing steel surface of the inner ring. Any lubrication of the sliding contact surfaces would disturb this transfer and shorten bearing life. Therefore, lubrication of these bearings is not advisable.

## Accuracy

The tolerances apply to outer ring without surface treatment and splitting. The outer rings become slightly out of round due to splitting. The roundness of the outer ring is restored once it is fitted in a housing bore produced in accordance with the specifications (Figure1). Measurements taken of the outside diameter of the unfitted bearing cannot be used as the original actual values for the outside diameter.

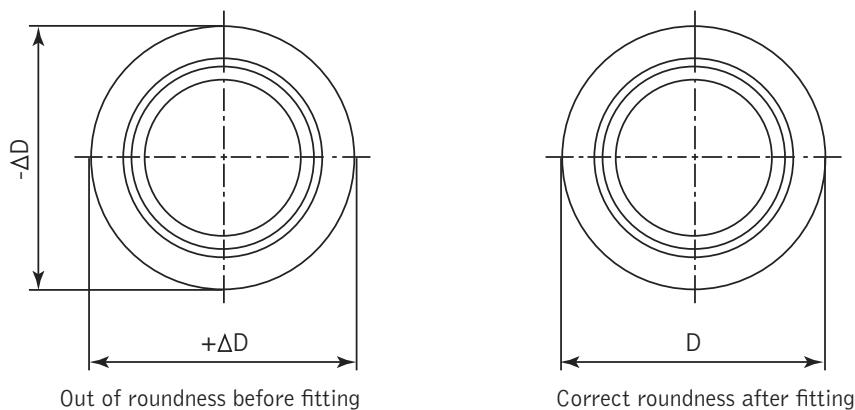



# Radial Spherical Plain Bearings

## Tolerances for Radial Spherical Plain Bearings

### Outer ring

d (mm)		$\Delta D_{mp}$ (um)		VDp (um)	VDmp (um)	$\Delta C_s$ (um)	
over	incl.	max	min	max	max	max	min
-	18	0	-8	10	6	0	-240
18	30	0	-9	12	7	0	-240
30	50	0	-11	15	8	0	-240
50	80	0	-13	17	10	0	-300
80	120	0	-15	20	11	0	-400
120	150	0	-18	24	14	0	-500
150	180	0	-25	33	19	0	-500
180	250	0	-30	40	23	0	-600
250	315	0	-35	47	26	0	-700
315	400	0	-40	53	30	0	-800
400	500	0	-45	60	34	0	-900
500	630	0	-50	67	38	0	-1000
630	800	0	-75	100	56	0	-1100
800	1000	0	-100	135	75	0	-1200

### Inner ring

d (mm)		$\Delta d_{mp}$		$\Delta d_{mp}^*$		Vdp	Vdmp	Vdp*	Vdmp*	$\Delta B_s$		$\Delta B_s^*$	
over	incl.	max	min	max	min	max	max	max	max	max	min	max	min
-	18	0	-8	+18	0	8	6	18	14	0	-120	0	-180
18	30	0	-10	+21	0	10	8	21	16	0	-120	0	-210
30	50	0	-12	+25	0	12	9	25	19	0	-120	0	-250
50	80	0	-15	+30	0	15	11	30	22	0	-150	0	-300
80	120	0	-20	+35	0	20	15	35	26	0	-200	0	-350
120	180	0	-25	+40	0	25	19	40	30	0	-250	0	-400
180	250	0	-30	+46	0	30	23	46	35	0	-300	0	-460
250	315	0	-35	+52	0	35	26	52	39	0	-350	0	-520
315	400	0	-40	+57	0	40	30	57	43	0	-400	0	-570
400	500	0	-45	-	-	45	34	-	-	0	-450	-	-
500	630	0	-50	-	-	50	38	-	-	0	-500	-	-

The deviations in the columns with symbol \* apply to spherical plain bearings of series GEEW ... ES.

## Symbols of Dimension and Tolerance

- D: Bearing bore diameter, nominal.
- $\Delta d_{mp}$ : Single plane mean bore diameter deviation.
- Vdp: Bore diameter variation in a single radial plane.
- Vdmp: Mean bore diameter variation.
- $\Delta B_s$ : Deviation of a single width of the inner ring.
- B: Width of inner ring, nominal.
- D: Bearing outside diameter, nominal.
- $\Delta D_{mp}$ : Single plane mean outside diameter deviation.
- VDp: Outside diameter variation in a single radial plane.
- VDmp: Mean outside diameter variation.
- $\Delta C_s$ : Deviation of a single width of the outer ring.
- C: Width of outer ring, nominal.
- $\Delta T_s$ : Actual deviation of width of the angular contact spherical plain bearing.
- $\Delta H_s$ : Actual deviation of height of the spherical plain thrust bearing.
- $\Delta h_s, \Delta h_{1s}$ : Center height deviation of rod ends or ball joint rod ends.

# Radial Spherical Plain Bearings



## Fits of Radial Spherical Plain Bearings

### Shaft Fits

Operating Conditions	Sliding Contact Surface Combination	
	Requiring Maintenance	Maintenance-Free
Loads of all kinds, clearance or transition fit	h6 / hardened shaft	h6, g6
Loads of all kinds, interference fit	m6	k6

### Housing Fits

Operating Conditions	Sliding Contact Surface Combination	
	Requiring Maintenance	Maintenance-Free
Light loads / Axial displacement required	H7	H7
Heavy loads	M7	K7
Light alloy housings	N7	M7

### Shaft Diameter Tolerances

Shaft Diameter (mm)		Shaft Diameter Tolerances (um)							
		g6		h6		k6		m6	
over	incl.	high	low	high	low	high	low	high	low
3	6	-4	-12	0	-8	+9	+1	+12	+4
6	10	-5	-14	0	-9	+10	+1	+15	+6
10	18	-6	-17	0	-11	+12	+1	+18	+7
18	30	-7	-20	0	-13	+15	+2	+21	+8
30	50	-9	-25	0	-16	+18	+2	+25	+9
50	80	-10	-29	0	-19	+21	+2	+30	+11
80	120	-12	-34	0	-22	+25	+3	+35	+13
120	180	-14	-39	0	-25	+28	+3	+40	+15
180	250	-15	-44	0	-29	+33	+4	+46	+17
250	315	-17	-49	0	-32	+36	+4	+52	+20
315	400	-18	-54	0	-36	+40	+4	+57	+21
400	500	-20	-60	0	-40	+45	+5	+63	+23
500	630	-22	-66	0	-44	+44	0	+70	+26

### Housing Bore Tolerances

Housing Bore Diameter (mm)		Housing Bore Tolerances (um)							
		H7		K7		M7		N7	
over	incl.	low	high	low	high	low	high	low	high
10	18	0	+18	-12	+6	-18	0	-23	-5
18	30	0	+21	-15	+6	-21	0	-28	-7
30	50	0	+25	-18	+7	-25	0	-33	-8
50	80	0	+30	-21	+9	-30	0	-39	-9
80	120	0	+35	-25	+10	-35	0	-45	-10
120	150	0	+40	-28	+12	-40	0	-52	-12
150	180	0	+40	-28	+12	-40	0	-52	-12
180	250	0	+46	-33	+13	-46	0	-60	-14
250	315	0	+52	-36	+16	-52	0	-66	-14
315	400	0	+57	-40	+17	-57	0	-73	-16
400	500	0	+63	-45	+18	-63	0	-80	-17
500	630	0	+70	-70	0	-	-	-	-
630	800	0	+80	-80	0	-	-	-	-
800	1000	0	+90	-90	0	-	-	-	-



# Radial Spherical Plain Bearings

Radial Internal Clearance

## Radial Spherical Plain Bearings and Steel-on-Steel Radial Spherical Plain Bearings

Series GE...E. GE...ES. GE...ES-2RS. GEEW...ES. GEEM...ES-2RS

d (mm)		Group C2 um		Group Normal um		Group C3 um	
over	incl.	min	max	min	max	min	max
-	12	8	32	32	68	68	104
12	20	10	40	40	82	82	124
20	35	12	50	50	100	100	150
35	60	15	60	60	120	120	180
60	90	18	72	72	142	142	212
90	140	18	85	85	165	165	245
140	240	18	100	100	192	192	284
240	300	18	110	110	214	214	318
300	320	18	135	135	261	261	287

Series GEG...E. GEG...ES. GEG...ES-2RS

d (mm)		Group C2 um		Group Normal um		Group C3 um	
over	incl.	min	max	min	max	min	max
-	10	8	32	32	68	68	104
10	17	10	40	40	82	82	124
17	30	12	50	50	100	100	150
30	50	15	60	60	120	120	180
50	80	18	72	72	142	142	212
80	120	18	85	85	165	165	245
120	160	18	100	100	192	192	284
160	220	18	100	100	192	192	284
220	280	18	110	110	214	214	318

Series GEZ...ES. GEZ...ES-2RS. GEWZ...ES. GEWZ...ES-2RS

d (mm)		Group Normal um	
over	incl.	min	max
-	15.875 / 0.625	50	150
15.875 / 0.625	50.8 / 2	80	180
50.8 / 2	76.2 / 3	100	200
76.2 / 3	152.4 / 6	130	230

# Radial Spherical Plain Bearings



## Series GEGZ...ES. GEGZ...ES-2RS

d (mm)		Group Normal um	
over	incl.	min	max
12.7 / 0.5	44.45 / 1.75	80	180
44.45 / 1.75	69.85 / 2.75	100	200
69.85 / 2.75	139.7 / 5.5	130	230

## Steel-on-PTFE Fabric and Steel-on-Copper Alloy Radial Spherical Plain Bearings

### Series GE...ET-2RS. GE...XT-2RS. GE...ET/X. GE...ET-2RS/X

d (mm)		Group Normal um	
over	incl.	min	max
-	20	0	40
20	35	0	50
35	60	0	60
60	90	0	72
90	140	0	85
140	240	0	100
240	300	0	110
300	340	125	239
340	420	135	261
420	600	145	285

### Series GEG...ET-2RS. GEG...XT-2RS

d (mm)		Group Normal um	
over	incl.	min	max
-	30	0	50
30	50	0	60
50	80	0	72
80	120	0	85
120	220	0	100
220	280	0	110



# Angular Contact Spherical Plain

The sphered sliding contact surfaces of angular contact spherical plain bearings are inclined at an angle to the bearing axis. They are therefore particularly suitable for carrying combined (radial and axial) loads. A single angular contact spherical plain bearing can only accept axial loads acting in one direction. Under radial loads, a force acting in the axial direction is produced in the bearing which must always be opposed by an equal force acting in the opposite direction. Therefore, the bearings are usually adjusted against a second bearing.

When two angular contact spherical plain bearings are arranged so that their sphere centers coincide, a clearance-free radial spherical plain bearing is obtained which can accommodate heavy radial loads as well as heavy axial loads in both directions. GRB angular contact spherical plain bearings are available with different sliding contact surface combinations, i.e. the sliding surfaces of inner and outer rings are made from different materials. There are two main groups: steel-on-steel angular contact spherical plain bearings and maintenance-free angular contact spherical plain bearings.

GRB steel-on-steel angular contact spherical plain bearings are made of carbon chromium steel and are hardened and phosphated which has characteristics of wear-resistance and wear-corrosion. The inner and outer rings sliding contact surface are treated with molybdenum disulphide. Bearings with this sliding contact surface combination require regular relubrication. To facilitate efficient lubrication, outer ring has an annular groove and two lubrication holes. The high strength of the sliding surfaces makes these bearings especially suitable for bearing arrangements where heavy loads of alternating direction, shock loads or heavy static loads have to be accommodated.

GRB maintenance-free angular contact spherical plain bearings have sliding contact surface combinations steel-on-PTFE fabric. They have very low friction and can be operated without maintenance. Any lubrication of the sliding contact surfaces will shorten bearing life. They are used for applications where long bearing lives are required without maintenance, or where operating conditions, such as inadequate lubrication or the absence of lubrication make the use of steel-on-steel bearing inadvisable. The maintenance-free bearings are primarily intended for applications where loads are heavy and have a constant direction.

## Design Characteristics

GRB steel-on-steel angular contact spherical plain bearings are made of carbon chromium steel and are hardened and phosphated. The inner and outer ring sliding contact surfaces are treated with molybdenum disulphide. Outer ring has an annular groove and two lubrication holes and sliding contact surface of outer ring has two cross grooves.

GRB maintenance-free angular contact spherical plain bearings are made of carbon chromium steel and are hardened. The sliding surface of the inner ring is treated with chromium plating.

**Permissible operating temperature range:** GRB steel-on-steel and steel-on-PTFE fabric angular contact spherical plain bearings can be used at temperature  $-50^{\circ}\sim+150^{\circ}$ . At higher temperature, the load carrying capacity will be reduced.

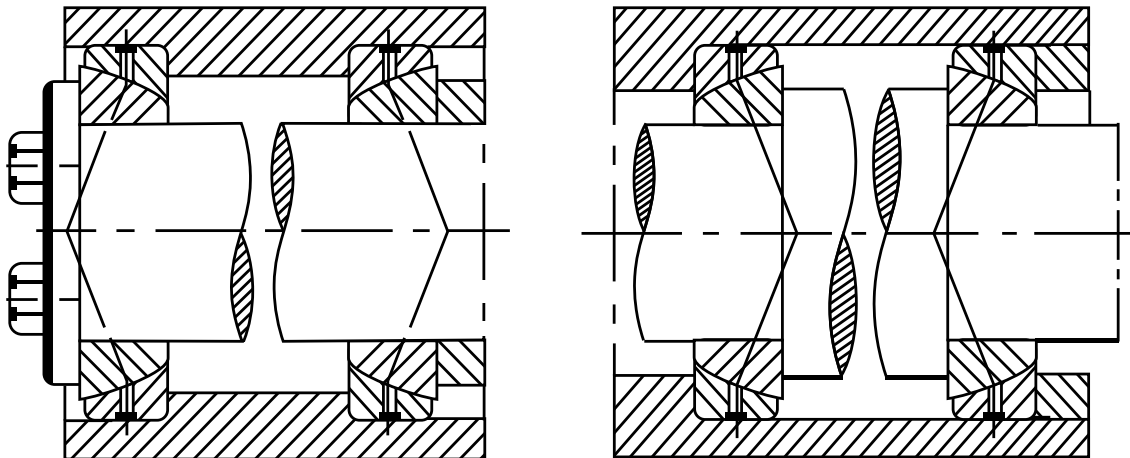

# Angular Contact Spherical Plain



## Outer Ring

D (mm)		$\Delta D_{mp}$ $\mu m$		$V D_p$ $\mu m$	$V D_{mp}$ $\mu m$	$\Delta C_s$ $\mu m$	
over	incl.	max	min	max	max	max	min
-	50	0	-14	14	11	0	-240
50	80	0	-16	16	12	0	-300
80	120	0	-18	18	14	0	-400
120	150	0	-20	20	15	0	-500
150	180	0	-25	25	19	0	-500
180	250	0	-30	30	23	0	-600
250	315	0	-35	35	26	0	-700

## Inner Ring and Width of Bearing

d (mm)		$\Delta d_{mp}$ $\mu m$		$V d_p$ $\mu m$	$V d_{mp}$ $\mu m$	$\Delta B_s$ $\mu m$		$\Delta T_s$ $\mu m$	
over	incl.	max	min	max	max	max	min	max	min
-	50	0	-12	12	9	0	-240	+250	-400
50	80	0	-15	15	11	0	-300	+250	-500
80	120	0	-20	20	15	0	-400	+250	-600
120	180	0	-25	25	19	0	-500	+350	-700
180	200	0	-30	30	23	0	-600	+350	-800

## Symbols of Dimension and Tolerance

- D: Bearing bore diameter, nominal.
- $\Delta d_{mp}$ : Single plane mean bore diameter deviation.
- $V d_p$ : Bore diameter variation in a single radial plane.
- $V d_{mp}$ : Mean bore diameter variation.
- $\Delta B_s$ : Deviation of a single width of the inner ring.
- B: Width of inner ring, nominal.
- D: Bearing outside diameter, nominal.
- $\Delta D_{mp}$ : Single plane mean outside diameter deviation.
- $V D_p$ : Outside diameter variation in a single radial plane.
- $V D_{mp}$ : Mean outside diameter variation.
- $\Delta C_s$ : Deviation of a single width of the outer ring.
- C: Width of outer ring, nominal.
- $\Delta T_s$ : Actual deviation of width of the angular contact spherical plain bearing.
- $\Delta H_s$ : Actual deviation of height of the spherical plain thrust bearing.
- $\Delta h_s, \Delta h_{1s}$ : Center height deviation of rod ends or ball joint rod ends.



# Angular Contact Spherical Plain

## Fits of Angular Contact Spherical Plain Bearings

### Shaft Fits

Operating Conditions	Sliding Contact Surface Combination	
	Requiring Maintenance	Maintenance-Free
Loads of all kinds, interference fit	m6	m6

### Housing Fits

Operating Conditions	Sliding Contact Surface Combination	
	Requiring Maintenance	Maintenance-Free
Loads of all kinds, interference fit	M7	M7
Loads of all kinds, can generally be displaced axially	J7	J7

### Shaft Diameter Tolerances

Shaft Diameter (mm)		Shaft Diameter Tolerances (µm)	
		m6	
over	incl.	high	low
-	30	+21	+8
30	50	+25	+9
50	80	+30	+11
80	120	+35	+13
120	180	+40	+15
180	250	+46	+17

### Housing Bore Tolerances

Housing Bore Diameter (mm)		Housing Bore Tolerances (µm)			
		J7		M7	
over	incl.	low	high	low	high
-	50	-11	+14	-25	0
50	80	-12	+18	-30	0
80	120	-13	+22	-35	0
120	150	-14	+26	-40	0
150	180	-14	+26	-40	0
180	250	-16	+30	-46	0
250	315	-16	+36	-52	0